

2ª Atualização Novembro 2016

Esquadrias Convencionais

EcoLine 2.5[®]

catálogo de perfis



PERFIL
O ALUMÍNIO DO BRASIL

www.perfilcm.com.br



ATENÇÃO

Observe as Instruções e Recomendações do Catálogo Técnico

Esquadrias Convencionais

EcoLine 2.5[®]

Este Catálogo é parte integrante do Sistema Construtivo em Alumínio EcoLine 2.5 desenvolvido pela Perfil Alumínio do Brasil S.A. e contém as informações para o correto procedimento de fabricação e montagem das peças de Esquadrias Convencionais.

- ❗ A fabricação e instalação de Esquadrias e Fachadas em alumínio devem ser conduzidas por profissionais com reconhecida experiência no mercado.
- ❗ A composição das peças de Esquadrias e ou Fachadas devem obedecer rigorosamente as orientações e recomendações constantes neste Catálogo Técnico. Eventuais dúvidas ou necessidade de informações adicionais devem ser solicitadas por escrito ao corpo técnico da Perfil Alumínio do Brasil S.A.
- ❗ A Legislação Brasileira estabelece que elementos aplicados à Construção Civil requer ciência, acompanhamento e responsabilidade técnica de Engenheiro Civil Pleno, devidamente graduado.
- ❗ A Perfil Alumínio do Brasil S.A. não se responsabiliza pelos desdobramentos do uso indevido dos perfis, montagem, instalação e ou quaisquer outras formas de aplicação das peças, que não obedeçam rigorosamente as recomendações deste Catálogo Técnico.



PERFIL
O ALUMÍNIO DO BRASIL

A EMPRESA	1.001
NORMAS / NBR 10821-12	2.001
GRÁFICOS DE DESEMPENHO	3.001
TIPOLOGIAS	4.001
TABELADOS	
BARRAS CHATAS.....	5.001
CANTONEIRAS-ABAS IGUAIS	5.001
CANTONEIRAS-ABAS DESIGUAIS.....	5.002
TUBOS REDONDOS.....	5.002
TUBOS RETANGULARES.....	5.003
TUBOS QUADRADOS	5.003
PERFIL U-ABAS IGUAIS.....	5.004
PERFIL U-ABAS DESIGUAIS	5.004
PERFIL T	5.005
VERGALHÃO REDONDO.....	5.005
VERGALHÃO QUADRADO	5.005
ÍNDICE DE PERFIS	6.001
PERFIS	7.001
ÍNDICE DE COMPONENTES	8.001
COMPONENTES	9.001
MONTAGENS 3D	10.001
PROJETOS DE MONTAGEM	11.001

Complexo Industrial em Viana-ES
Mais de 20 mil m² de área construída

Uma história com perfil de trabalho, dedicação e conquistas

Criada em 1995, a Perfil Alumínio tem conquistado ao longo dos anos, destaque reconhecido entre as melhores empresas de setor. No início, focada na distribuição de perfis de alumínio, a partir de 2010 ampliou a participação do mercado com atuação setorizada. Em uma área de 250 mil m², todo o complexo industrial de Viana-Es, acomoda três unidades de produção: O Processo de Anodização, Câmara de Pintura Eletrostática e uma Linha de Extrusão Automática de 7", traduzindo assim, o conceito de empresa completa.



EXTRUSÃO



ANODIZAÇÃO



PINTURA



DISTRIBUIÇÃO

Sistema eficiente e equipe altamente preparada

- 2.000 Toneladas de força. billets 178mm;
- Principais ligas de têmperas;
- Mesa de saída. handling de 50 metros de comprimento;
- Esticadeira com correção eletrônica(tracklos);
- Perfis Complexos e com medidas especiais;
- Forno de 16 metros;
- Departamento de projetos e desenvolvimento de ferramentas;
- Ferramentaria de correção e nitretação própria;
- Perfis de grandes dimensões;
- Superfícies constantes e precisão dimensional.

Totalmente Planejada - P20 DE 7"

Processos tecnológicos e padrão mundial

- Tratamento anódico por imersão (flash anodizing);
- Capacidade para 600 toneladas por mês;
- Perfis com até 6,8 metros;
- Garantia assegurada de 5 anos;
- Processo homologado por institutos oficiais;
- 28 Tanques sequenciais;
- Tonalidades firmes com selagem instantânea;
- Opção de acabamento acetinado;
- Alta fidelidade aos padrões das texturas.

Instalações Modernas

Câmara de Pintura a Pó Cabine Linear Contínua

- Capacidade para 6.000 toneladas por mês;
- Perfis com até 7 metros;
- Padrões de cores RAL;
- Procedimento QUALICOAT;
- British Standard 6496;
- ABNT 14 125 e Normas Complementares;
- Rigorosa Gestão da Qualidade – PERFIL;
- Secagem Infra-RED;
- Maior e melhor aderência de lavagem;
- Processo normatizado e certificado;
- Ampla gama de cores e texturas;
- Acabamento perfeito.

Sistema Powder Coat

Atendimento para todo o Brasil Estoque e Armazenagem

- Perfis de alumínio e materiais construtivos;
- 6 Mil m² de armazenagem;
- Mais de 4 mil itens em estoque;
- Área de estoque a pronta entrega;
- Operação logística eficaz;
- Opção de perfis in natura, pintados ou anodizados;
- Todas as linhas abertas e convencionais;
- Acessórios e componentes.

Atendimento Completo

REPRESENTANTES NO BRASIL

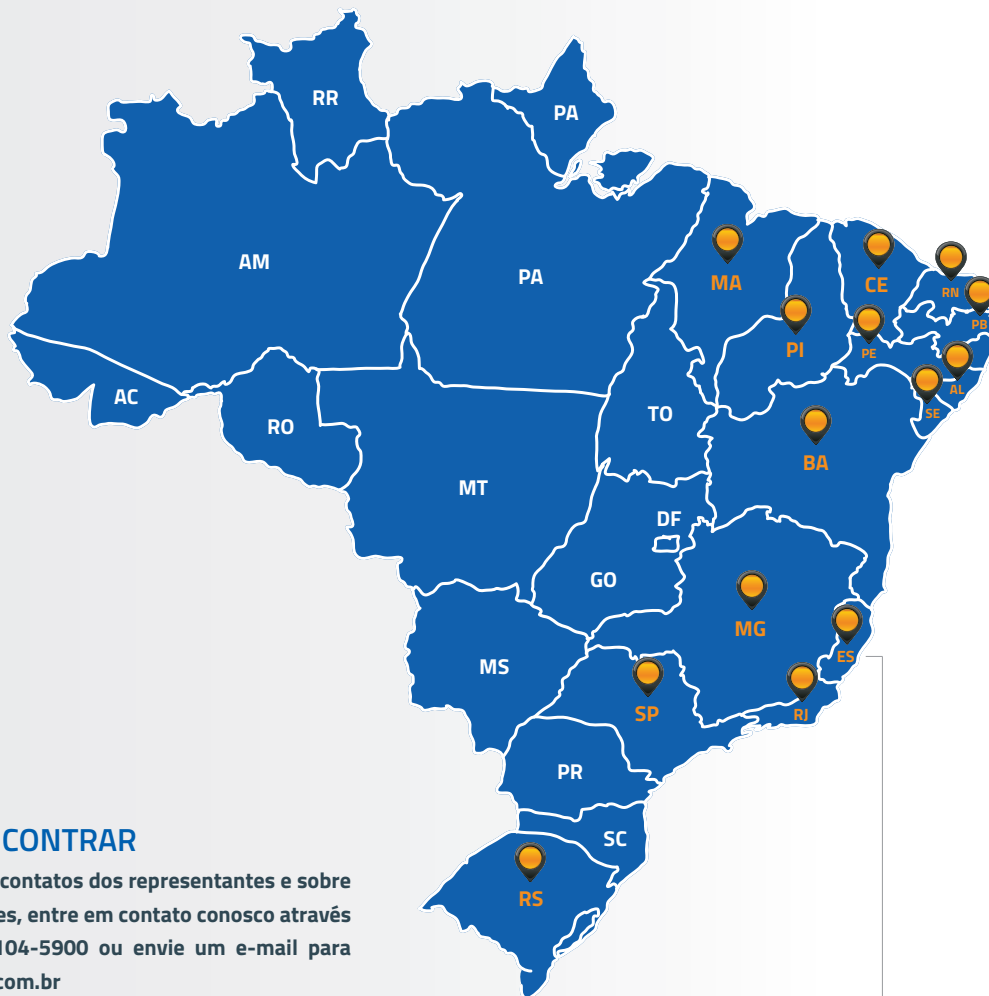

ONDE NOS ENCONTRAR

Para saber quais os contatos dos representantes e sobre as demais localidades, entre em contato conosco através do telefone (27) 2104-5900 ou envie um e-mail para perfilcm@perfilcm.com.br

ATENDIMENTO PARA TODO O BRASIL



LOCALIZAÇÃO ESTRATÉGICA - SUDESTE
ACESSO PELA BR 101 (DUPLICADA)



UNIDADE INDUSTRIAL

VIANA - ES



CENTRO DE DISTRIBUIÇÃO

VILA VELHA - ES



Responsabilidade Social e Cidadania:





DEPARTAMENTO TÉCNICO ESPECIALIZADO

- Obras: Especificação técnica de sistemas construtivos
 - Projetos e engenharia
 - CTP: Cursos, treinamentos e palestras
 - Suporte técnico, orientação e desenvolvimento

CTP -CENTRO DE TREINAMENTO PERFIL

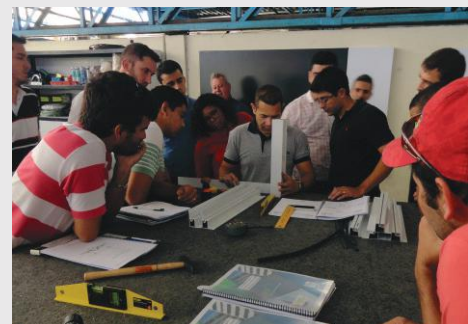

MATERIAIS CONSTRUTIVOS



SISTEMAS CONSTRUTIVOS EXCLUSIVOS

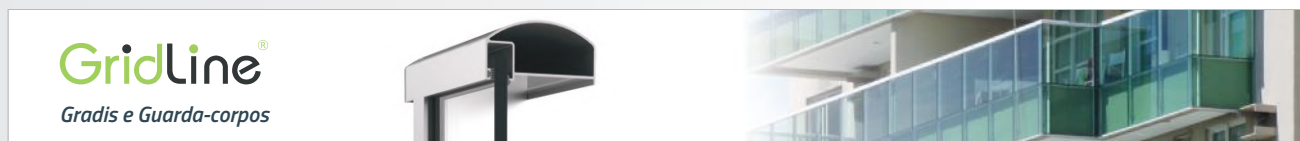
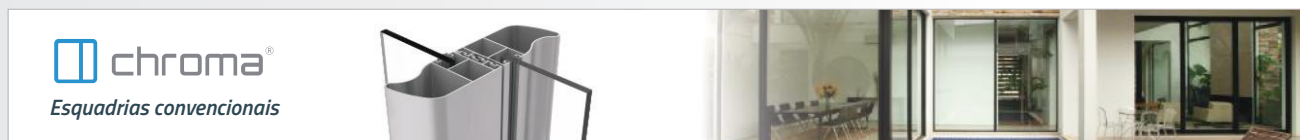
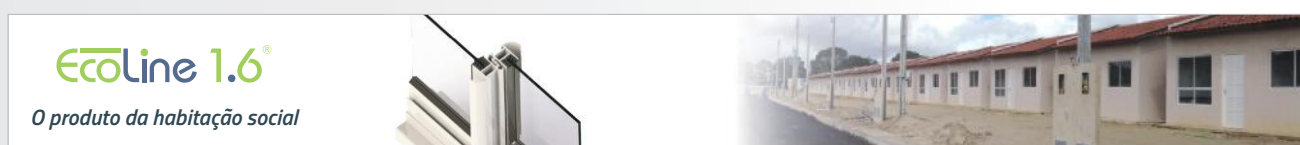

Determinação da pressão de ventos que deve ser aplicada na esquadria conforme o local da edificação
Identifique no Mapa das Isopletas a velocidade dos ventos característica da região da edificação.

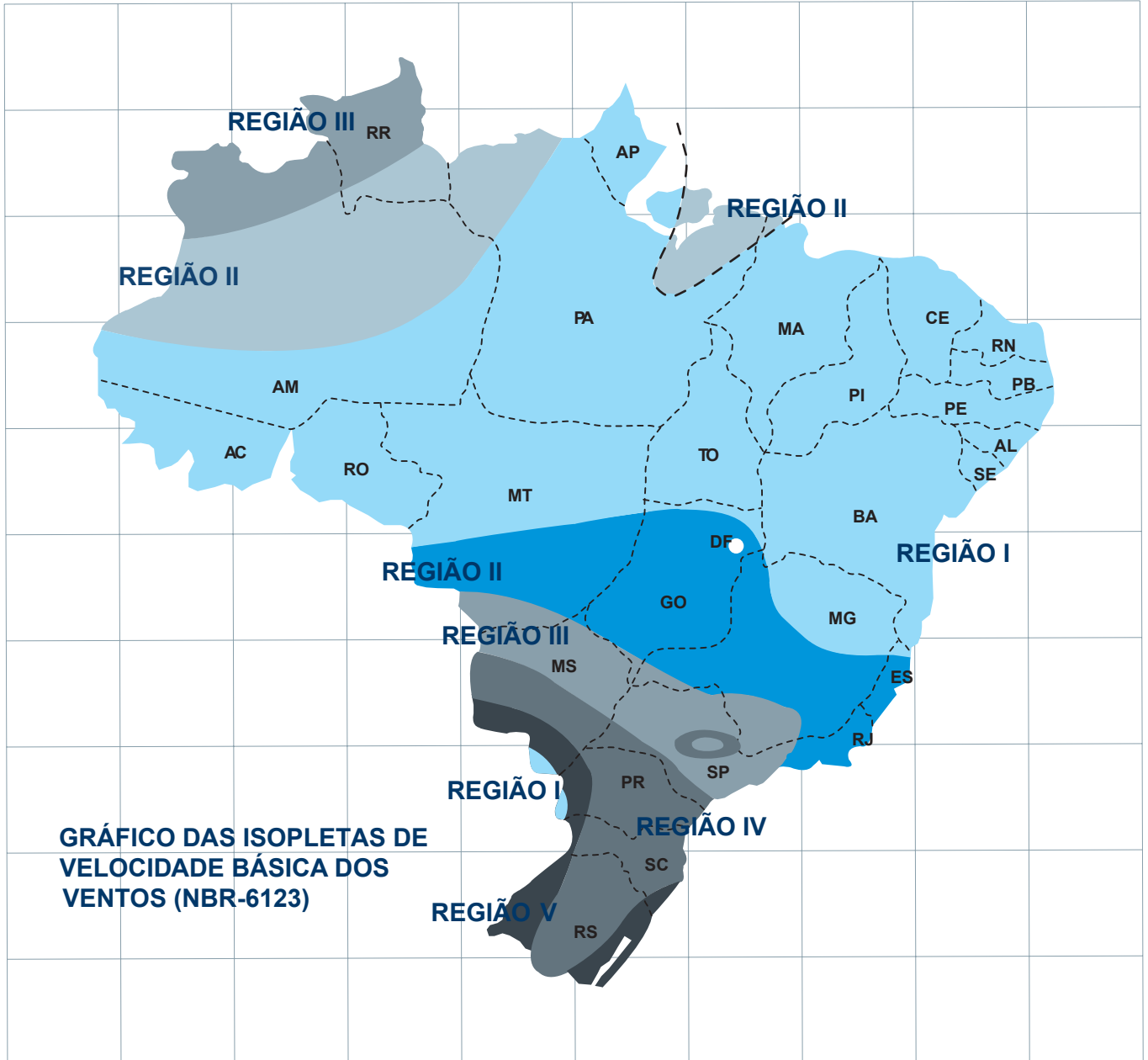

Região		velocidade		pressão	
		m/s	km/h	kg/m ²	PA
	I	30	108	77	756
	II	35	126	105	1030
	III	40	144	137	1345
	IV	45	162	173	1698
	V	50	180	214	2100

Nota: adotado para cálculo escala internacional de **BEAUFORT**

Com a Região encontrada no gráfico das isopletas, verifique na tabela abaixo a Pressão de Ensaio compatível com a Altura ou Quantidade de pavimentos de sua edificação (Atenção: ver nota "A" abaixo);

Tabela de pressão de ensaio para cargas uniformemente distribuídas

Quantidade de pavimentos	Altura máxima	Região do País	Pressão de ensaio P_e , em (Pa) Positiva e negativa $P_e = P_p \times 1,2$	Pressão de segurança P_{sem} (Pa) Positiva e negativa $P_s = P_e \times 1,5$	Pressão de água P_a , em (Pa) $P_a = P_p \times 0,20$
02	6 m	I	350	520	60
		II	470	700	80
		III	610	920	100
		IV	770	1160	130
		V	950	1430	160
05	15 m	I	420	640	70
		II	580	860	100
		III	750	1130	130
		IV	950	1430	160
		V	1180	1760	200
10	30 m	I	500	750	80
		II	680	1030	110
		III	890	1340	150
		IV	1130	1700	190
		V	1400	2090	230
20	60 m	I	600	900	100
		II	815	1220	140
		III	1060	1600	180
		IV	1350	2020	220
		V	1660	2500	280
30	90 m	I	660	980	110
		II	890	1340	150
		III	1170	1750	200
		IV	1480	2210	250
		V	1820	2730	300

Com a "Pressão de Ensaio" encontrada, é possível verificar nas páginas dos "Gráficos de Desempenho", as medidas máximas de largura e altura para as tipologias existentes em sua edificação. Para isso, ligue o eixo de largura ou de altura na curva referente à pressão de ensaio requerida e verifique que a dimensão máxima correspondente (Atenção: ver nota "B" abaixo).

NOTAS:

- Para os edifícios com especificações, localização, necessidades e exigências especiais de utilização, deve ser consultada a norma **ABNT NBR- 6123** para a determinação da "Pressão de Ensaio" (P_e) a ser adotada, prevalecendo como mínimos os valores da tabela acima. Fachadas cortinas e coberturas também devem ser projetadas e especificadas, quanto às pressões de vento, conforme a **ABNT NBR-6123**. Os projetos e cálculos estruturais pertinentes a estas tipologias devem ser assumidos por profissional técnico habilitado;
- Nos gráficos de desempenho a seguir, foram considerados os valores de "Pressão de Ensaio" e "Pressão de Segurança", de acordo com a norma **ABNT NBR-10821**, para fachadas entre vãos;
- A espessura mínima do vidro deve ser calculada utilizando-se o valor da "Pressão de Segurança" requerida para a esquadria (para maiores informações consultar a **ABNT NBR-10821** - Partes 2 e 3).

JANELA DE CORRER 2 FOLHAS

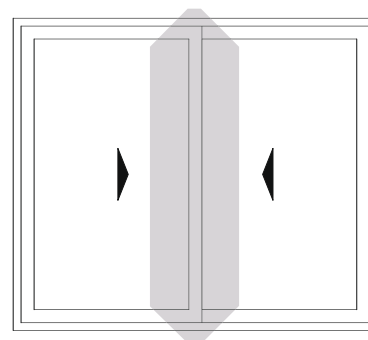

ELEVAÇÃO SEM ESCALA

MONTAGEM
ESCALA 1:1

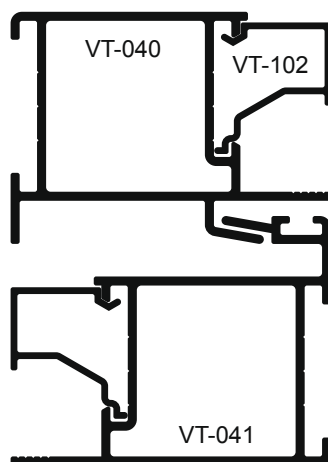

PERFIL

Jx: 2,4584 cm⁴

Wx: 1,4115 cm³

CONJUNTO

Jx: 4,9167 cm⁴

Wx: 2,8230 cm³

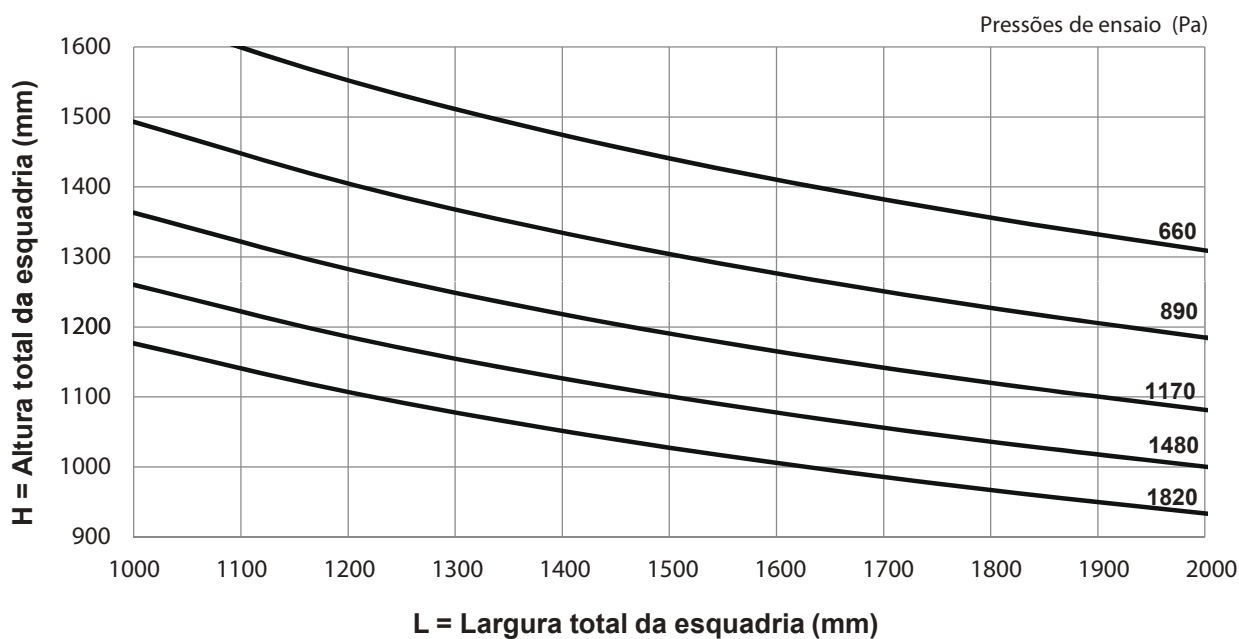

JANELA DE CORRER 2 FOLHAS

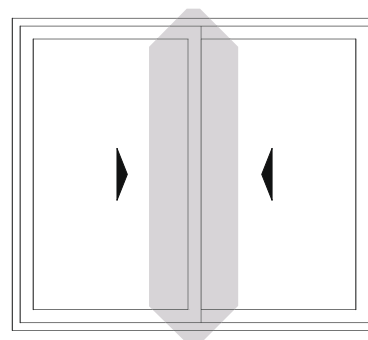

ELEVAÇÃO SEM ESCALA

MONTAGEM
 ESCALA 1:1

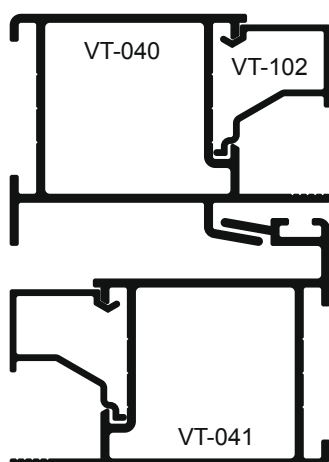

PERFIL
Jx: 2,4584 cm ⁴
Wx: 1,4115 cm ³
CONJUNTO
Jx: 4,9167 cm ⁴
Wx: 2,8230 cm ³

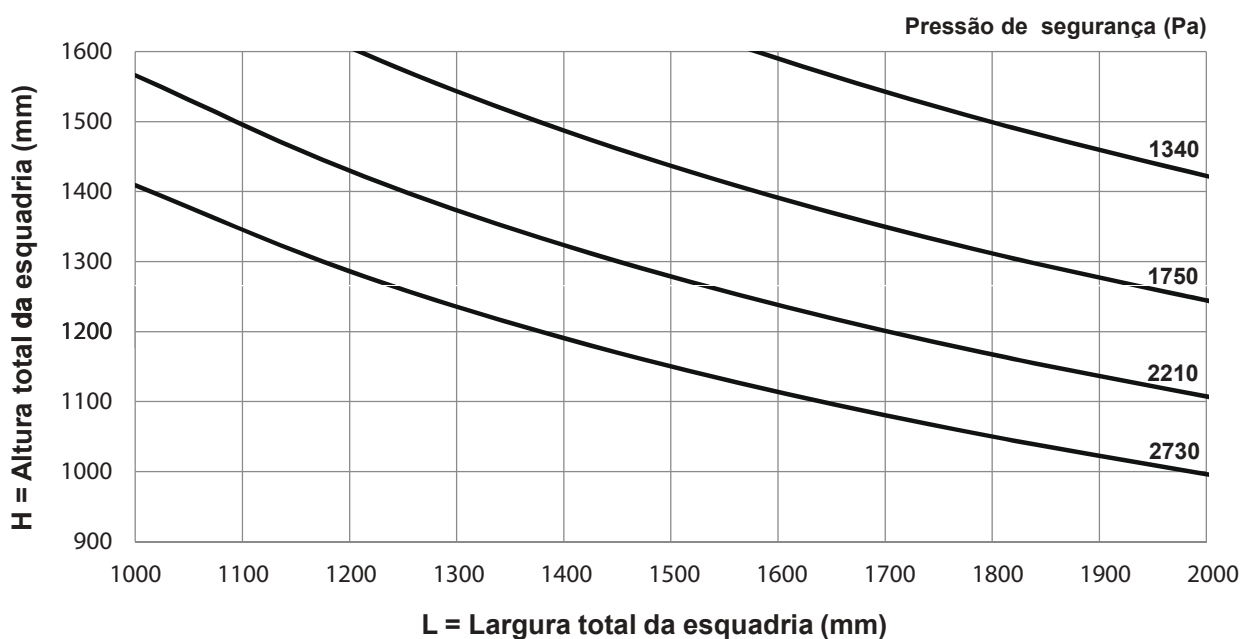

JANELA DE CORRER 4 FOLHAS

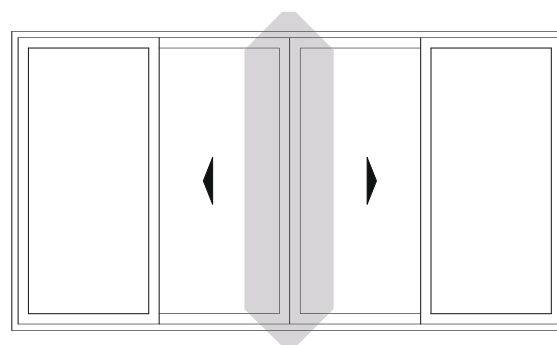

ELEVAÇÃO SEM ESCALA

MONTAGEM
 ESCALA 1:1

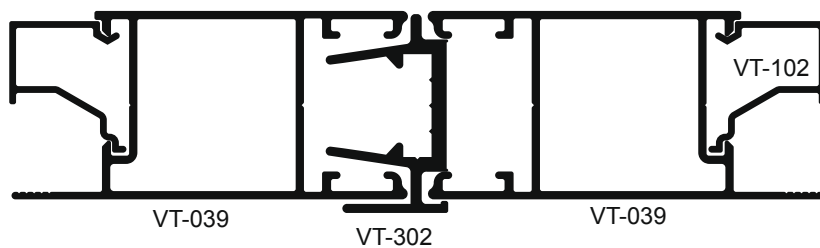

PERFIL
Jx: 2,6712 cm ⁴
Wx: 1,9755 cm ³
CONJUNTO
Jx: 5,3423 cm ⁴
Wx: 3,9510 cm ³

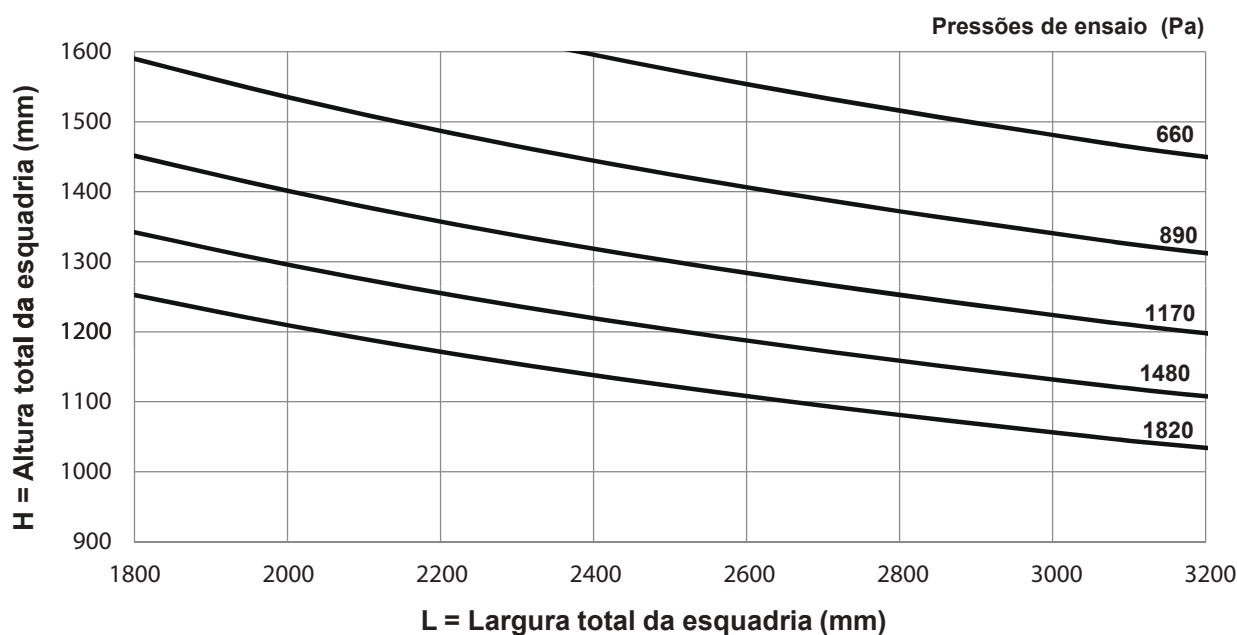

JANELA DE CORRER 4 FOLHAS

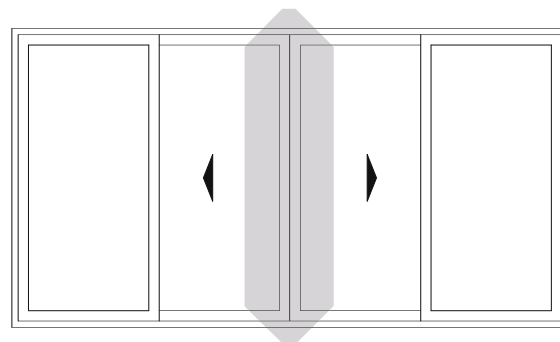

ELEVAÇÃO SEM ESCALA

MONTAGEM
 ESCALA 1:1

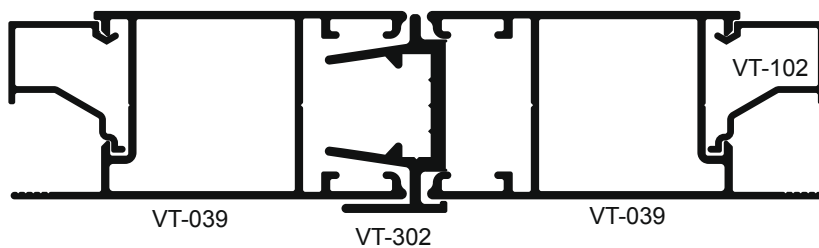

PERFIL

Jx: 2,6712 cm⁴

Wx: 1,9755 cm³

CONJUNTO

Jx: 5,3423 cm⁴

Wx: 3,9510 cm³

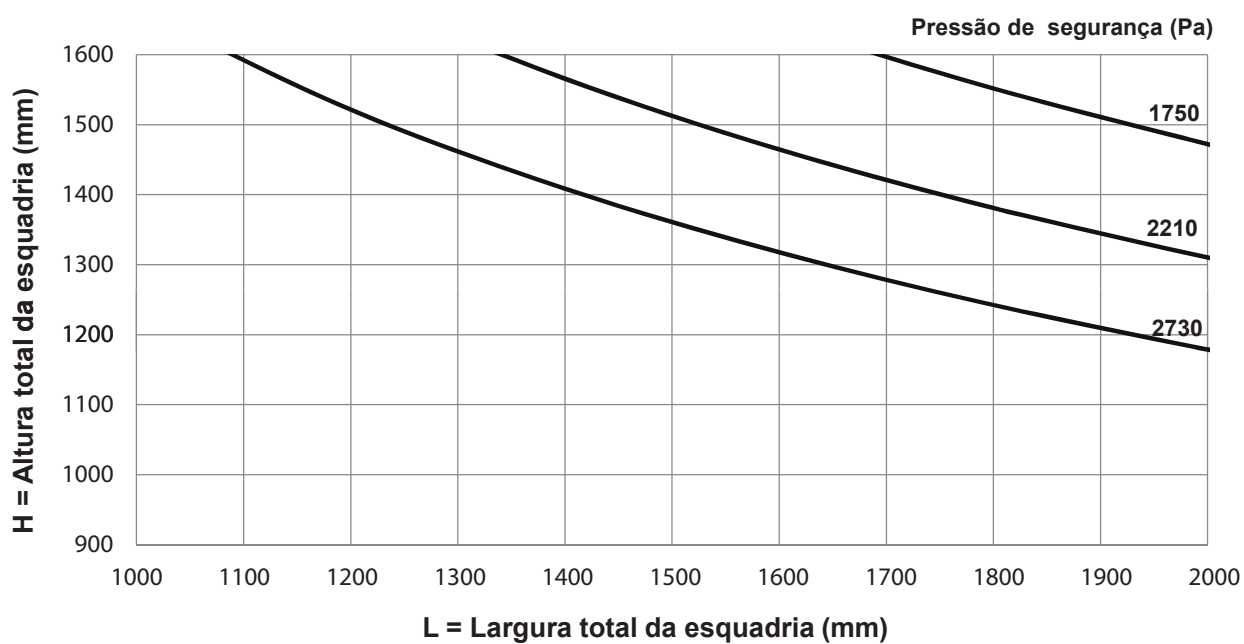

PORTA DE CORRER 2 FOLHAS

MONTAGEM
 ESCALA 1:1

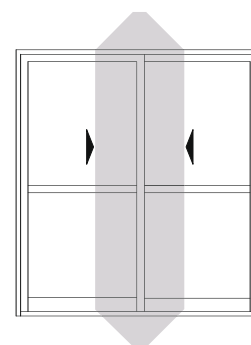
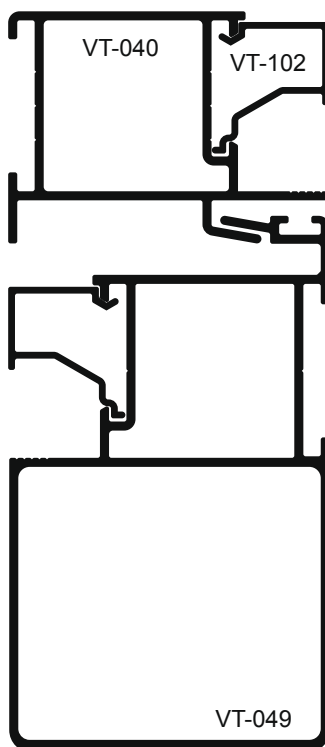

ELEVAÇÃO SEM ESCALA

PERFIL

Jx: 12,9642 cm⁴

Wx: 3,9420 cm³

CONJUNTO

Jx: 25,9283 cm⁴

Wx: 7,8840 cm³

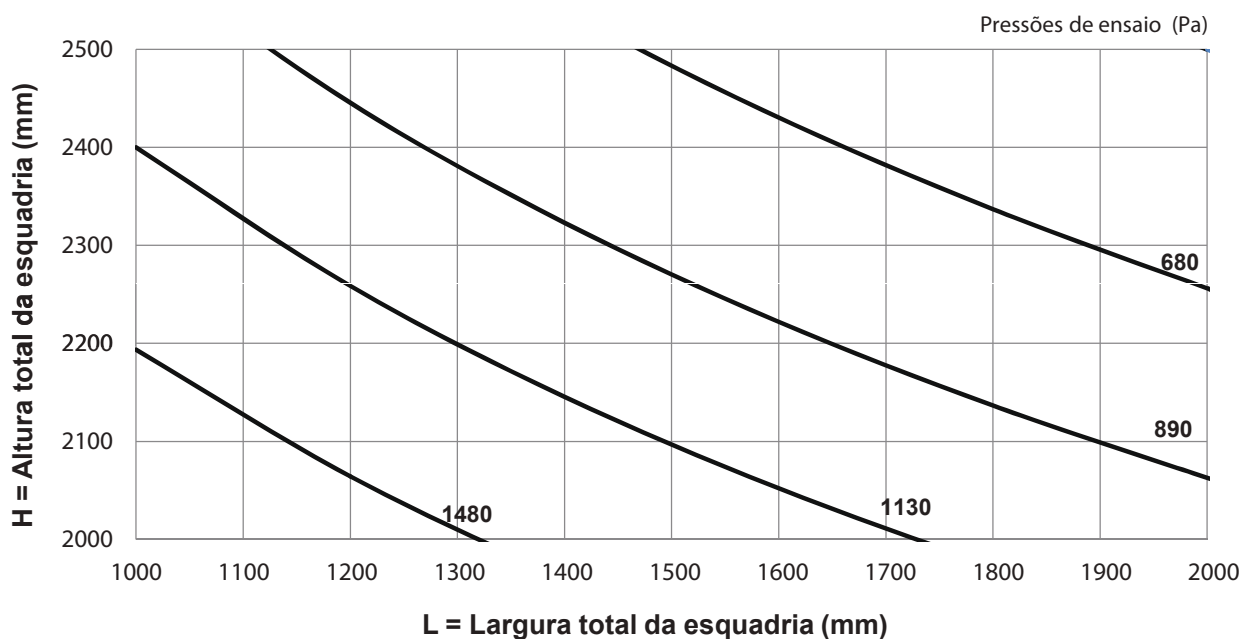

PORTA DE CORRER 2 FOLHAS

MONTAGEM
 ESCALA 1:1

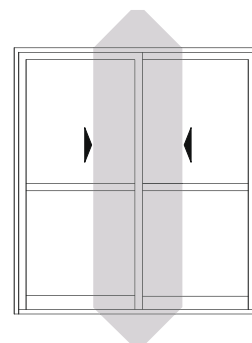
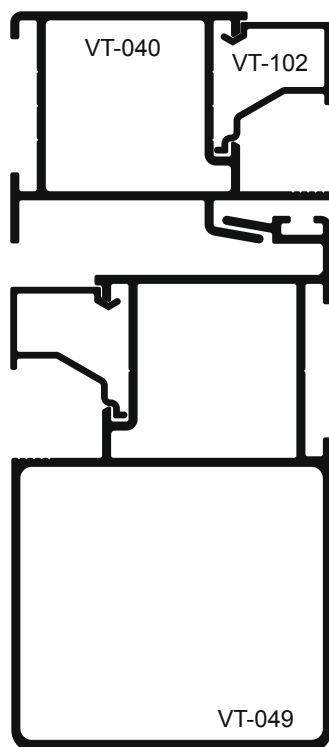

ELEVAÇÃO SEM ESCALA

PERFIL

Jx: 12,9642 cm⁴

Wx: 3,9420 cm³

CONJUNTO

Jx: 25,9283 cm⁴

Wx: 7,8840 cm³

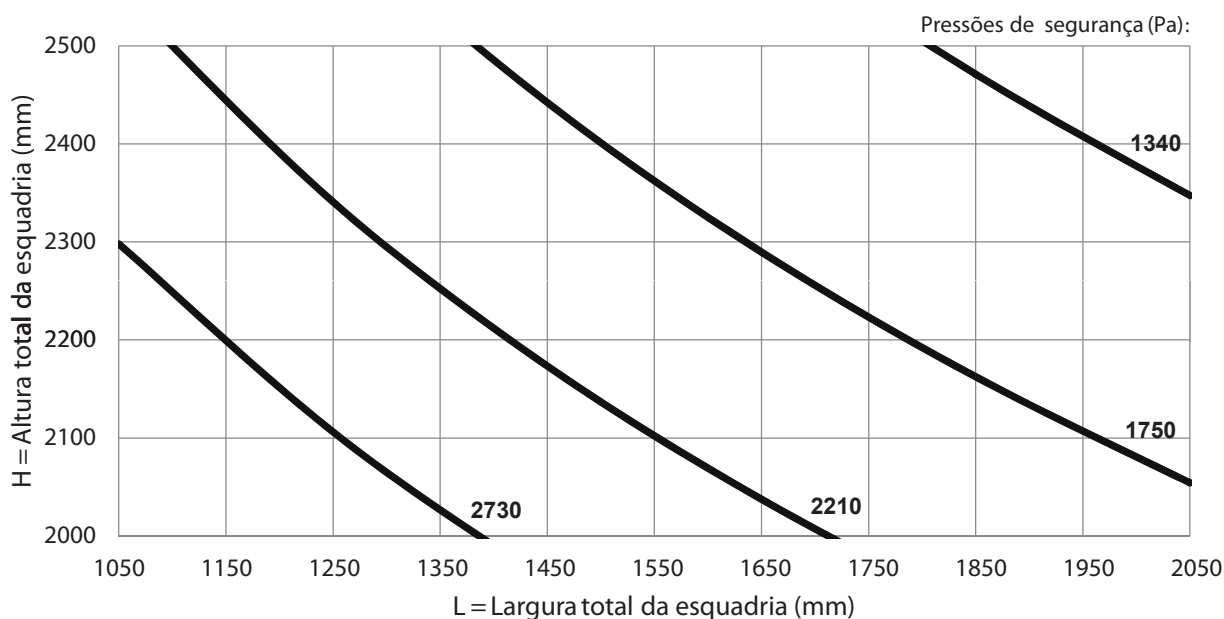

PORTA DE CORRER 4 FOLHAS

MONTAGEM
 ESCALA 1:1

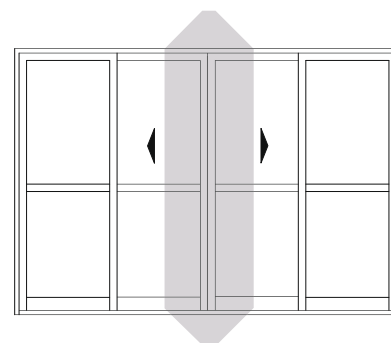
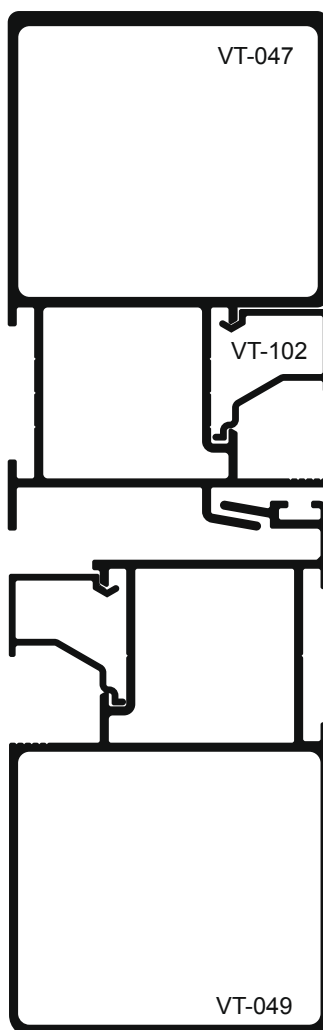

ELEVAÇÃO SEM ESCALA

PERFIL
Jx: 21,2250 cm ⁴
Wx: 5,6200 cm ³
CONJUNTO
Jx: 42,4500 cm ⁴
Wx: 11,2400 cm ³

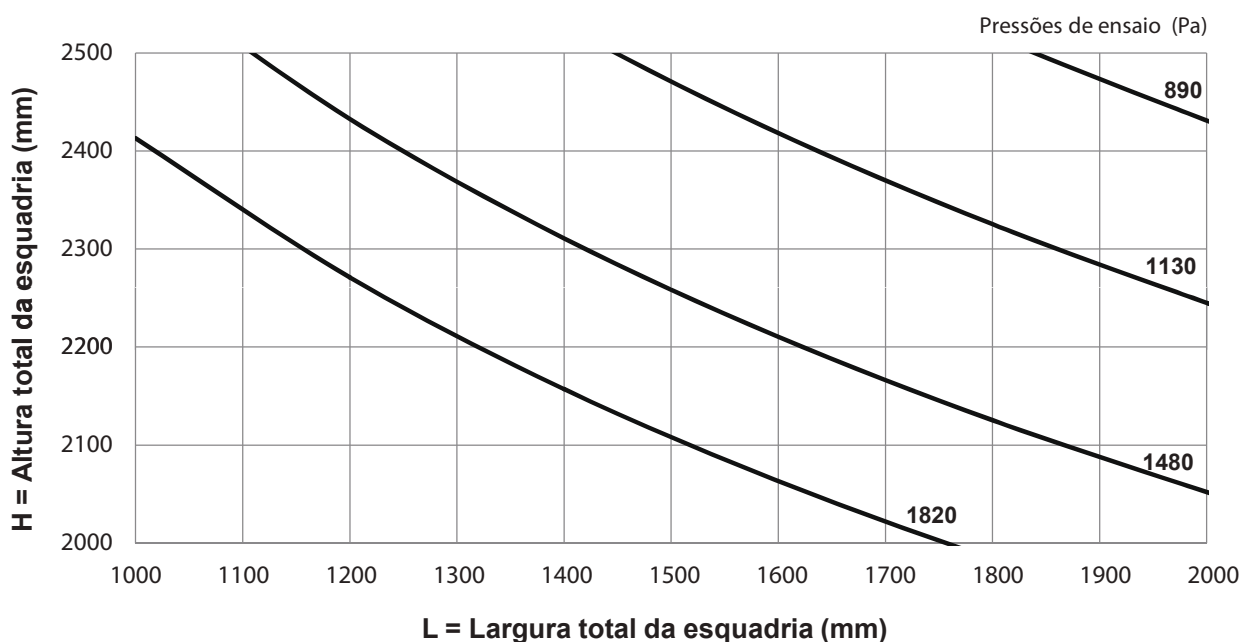

PORTA DE CORRER 4 FOLHAS

MONTAGEM
 ESCALA 1:1

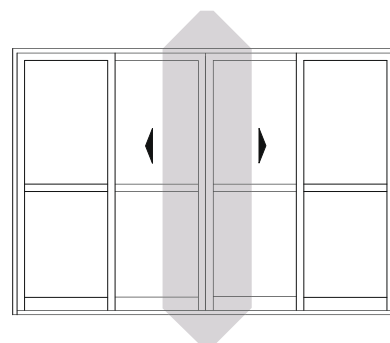
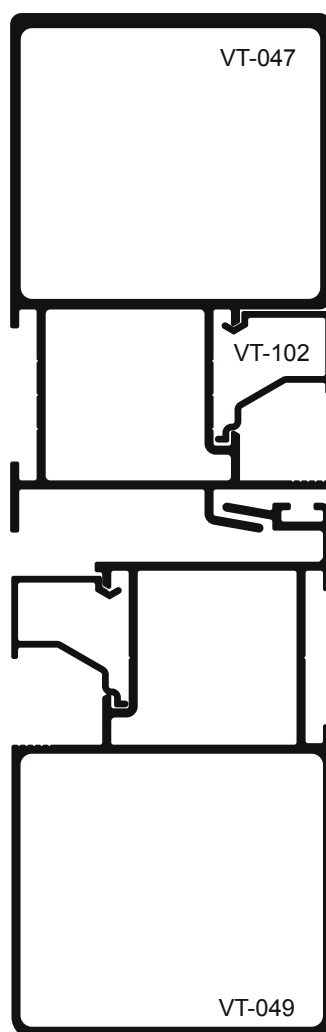

ELEVAÇÃO SEM ESCALA

PERFIL

Jx: 21,2250 cm⁴

Wx: 5,6200 cm³

CONJUNTO

Jx: 42,4500 cm⁴

Wx: 11,2400 cm³



PORTA DE CORRER 4 FOLHAS

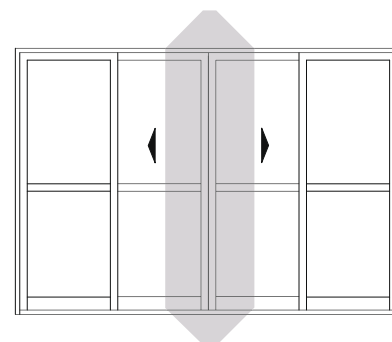

ELEVAÇÃO SEM ESCALA

MONTAGEM
ESCALA 1:1

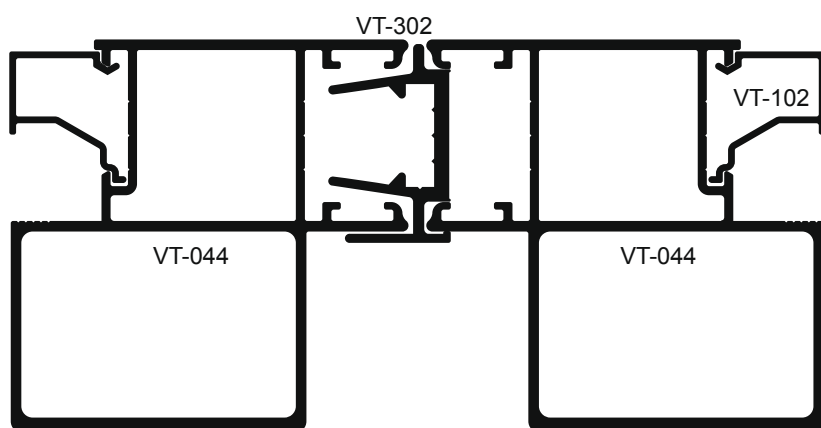

PERFIL
Jx: 12,8533 cm ⁴
Wx: 4,6685cm ³
CONJUNTO
Jx: 25,7065 cm ⁴
Wx: 9,3370 cm ³

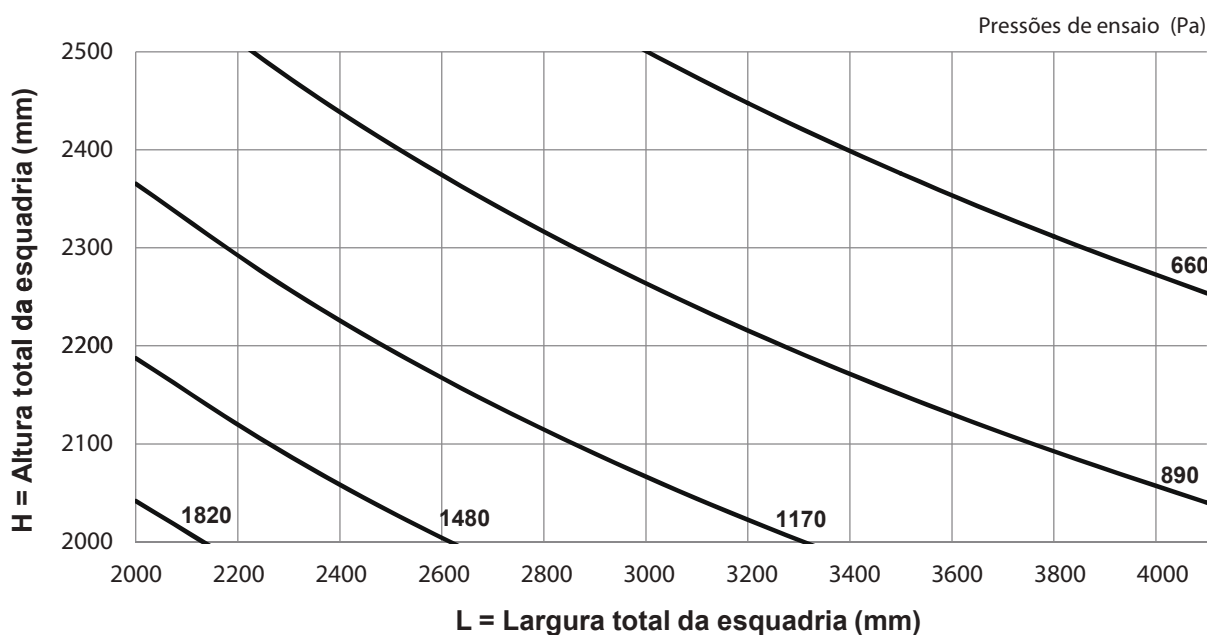

PORTA DE CORRER 4 FOLHAS

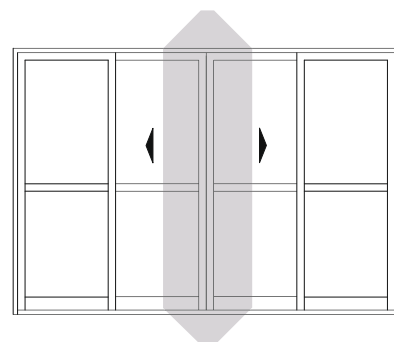

ELEVAÇÃO SEM ESCALA

MONTAGEM
 ESCALA 1:1

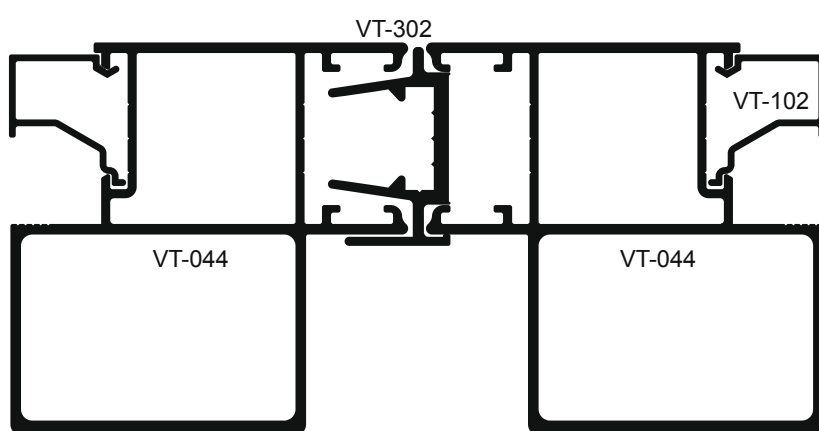

PERFIL

Jx: 12,8533 cm⁴

Wx: 4,6685cm³

CONJUNTO

Jx: 25,7065 cm⁴

Wx: 9,3370 cm³

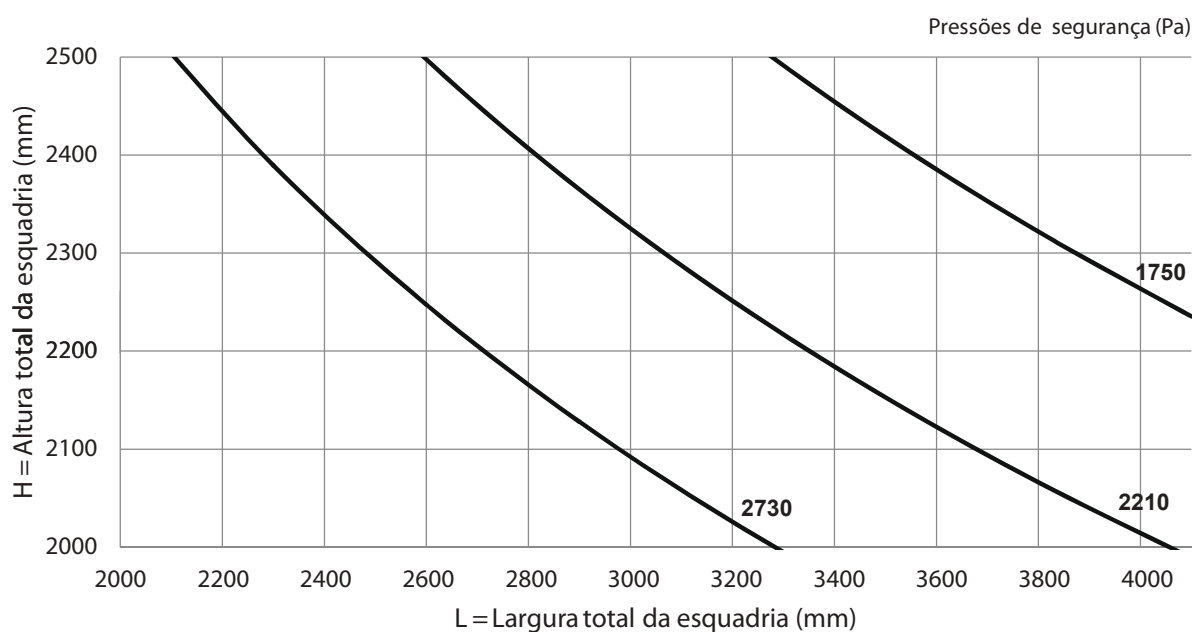

JANELA 2 FOLHAS

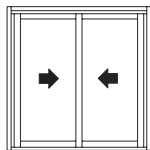

JANELA 3 FOLHAS

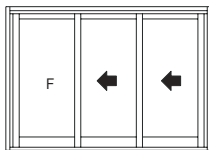

JANELA 4 FOLHAS

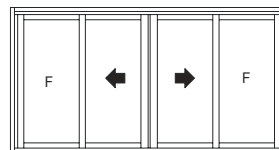

JANELA 2 FOLHAS C/ BANDEIRA MÓVEL

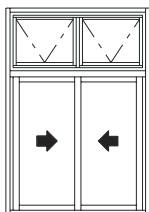

JANELA 4 FOLHAS C/ PEITORIL FIXO

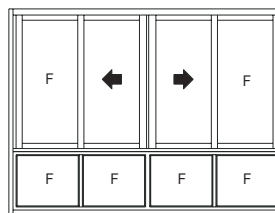

JANELA 3 FOLHAS

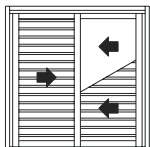

JANELA 4 FOLHAS

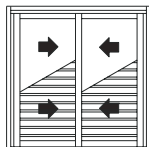

JANELA 6 FOLHAS

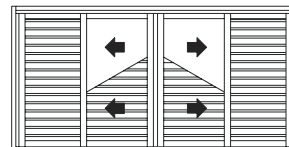

PORTA 3 FOLHAS

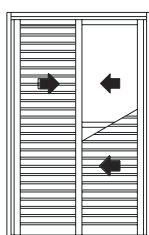

PORTA 2 FOLHAS

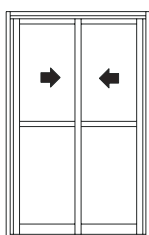

PORTA 4 FOLHAS

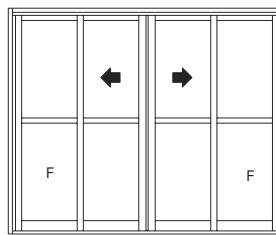

PORTA 3 FOLHAS

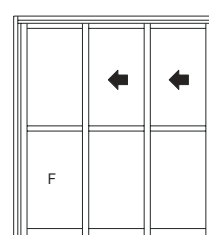

JANELA MAXIM-AR 1 FOLHA

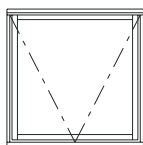

JANELA MAXIM-AR 2 FOLHAS

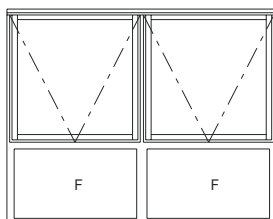

PORTA 1 FOLHAS

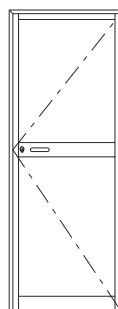

PORTA 2 FOLHAS

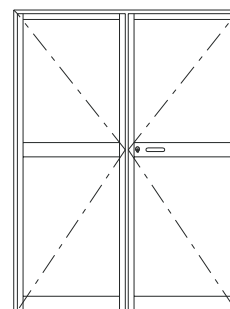

BARRAS CHATAS

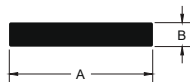

CÓDIGO	PESO (Kg/m)	MILÍMETROS		POLEGADAS	
		A	B	A	B
BC-002	0,108	12,70	3,17	1/2	1/8
BC-010	0,272	15,88	6,35	5/8	1/4
BC-015	0,163	19,05	3,18	3/4	1/8
BC-025	0,217	25,40	3,17	1	1/8
BC-060	0,436	50,80	3,18	2	1/8
BC-118	2,237	118,00	7,00	-	-

CANTONEIRAS ABAS IGUAIS

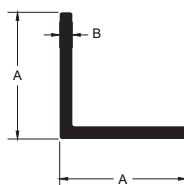

CÓDIGO	PESO (Kg/m)	MILÍMETROS		POLEGADAS	
		A	B	A	B
CT-001	0,102	12,70	1,58	1/2	1/16
CT-005	0,129	15,88	1,59	5/8	1/16
CT-008	0,120	19,05	1,20	3/4	-
CT-007	0,139	19,05	1,40	3/4	-
CT-015	0,161	25,40	1,20	1	-
CT-016	0,200	25,40	1,50	1	-
CT-019	0,410	25,40	3,18	1	1/8
CT-090	0,266	31,75	1,59	1.1/4	1/16
CT-022	0,518	31,75	3,18	1.1/4	1/8
CT-047	0,317	38,10	1,59	1.1/2	1/16
CT-026	0,626	38,10	3,17	1.1/2	1/8
CT-050	0,430	50,80	1,59	2	1/16
CT-031	0,539	50,80	2,00	2	-
CT-032	0,847	50,80	3,18	2	1/8
CT-033	1,249	50,80	4,76	2	3/16

CANTONEIRAS ABAS DESIGUAIS

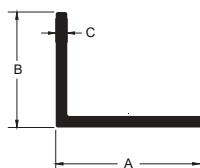

CÓDIGO	PESO (Kg/m)	MILÍMETROS			POLEGADAS		
		A	B	C	A	B	C
CT-209	0,141	32,00	16,20	1,20	-	-	-
CT-300	0,518	50,80	12,70	3,18	2	1/2	1/8
CT-218	0,436	50,80	31,75	2,00	2	1.1/4	-

TUBOS REDONDOS



CÓDIGO	PESO (Kg/m)	MILÍMETROS			POLEGADAS	
		A	B	C	A	C
TR-002	0,102	9,52	6,52	1,50	3/8	-
TR-005	0,150	12,70	9,53	1,59	1/2	1/16
TR-004	0,122	12,70	10,20	1,25	1/2	-
TR-1015	0,100	12,70	10,70	1,00	1/2	-
TR-250	0,343	15,87	9,52	3,18	5/8	1/8
TR-014	0,193	15,88	12,71	1,59	5/8	1/16
TR-883	0,127	15,88	13,88	1,00	5/8	-
TR-927	0,154	19,05	17,05	1,00	3/4	-
TR-7255	0,180	22,22	20,22	1,00	7/8	-
TR-040	0,321	25,40	22,22	1,59	1	1/16
TR-039	0,205	25,40	23,40	1,00	1	-
TR-055	0,408	31,75	28,57	1,59	1.1/4	1/16
TR-383	0,322	31,75	29,27	1,24	1.1/4	-
TR-070	0,493	38,10	34,92	1,59	1.1/2	1/16
TR-098	0,664	50,80	47,62	1,59	-	1/16
TR-907	0,533	50,80	48,30	1,27	2	-
TR-5065	3,133	54,00	38,00	8,00	-	-
TR-5054	4,154	69,00	53,00	8,00	-	-
TR-5053	4,751	71,00	53,00	9,00	-	-
TR-5052	5,677	74,00	53,00	10,50	-	-
TR-311	1,047	76,20	72,90	1,65	3	-
TR-874	0,807	76,20	73,70	1,27	3	-
TR-135	1,237	76,70	72,80	1,95	-	-
TR-163	2,656	101,6	95,24	3,18	4	-
TR-162	2,192	101,6	96,40	2,60	4	-
TR-7299	1,341	101,6	98,44	1,58	4	1/16

TUBOS RETANGULARES



CÓDIGO	PESO (Kg/m)	MILÍMETROS			POLEGADAS		
		A	B	C	A	B	C
TG-001	0,285	25,40	12,70	1,50	1	1/2	-
TG-2512	0,214	25,40	12,70	1,10	1	1/2	-
TG-3020	0,429	30,00	20,00	1,70	-	-	-
TG-3025	0,369	30,00	25,00	1,30	-	-	-
DS-192	0,337	47,00	24,00	0,90	-	-	-
TG-004	0,492	50,80	12,70	1,50	2	1/2	-
TG-083	0,365	50,80	12,70	1,10	2	1/2	-
DS-193	0,402	50,80	25,40	1,00	2	1	-
TG-005	0,595	50,80	25,40	1,50	2	1	-
TG-108	0,698	50,80	38,10	1,50	2	1.1/2	-
TG-026	0,875	60,30	38,10	1,70	2.3/8	1.1/2	-
TG-203	1,057	63,50	38,10	2,00	2.1/2	1.1/2	-
TG-7625	0,801	76,20	25,40	1,50	3	1	-
TG-014	1,183	76,20	38,10	1,98	3	1.1/2	-
TG-7406	0,904	76,20	38,10	1,50	3	1.1/2	-
TG-9550	1,235	95,00	50,80	1,60	-	2	-
TG-015	0,851	100,00	15,00	1,40	-	-	-
TG-540	1,471	101,60	38,10	2,00	4	1.1/2	-
TG-019	1,915	101,60	50,50	2,40	4	-	-
TG-072	1,450	101,60	50,80	1,80	4	2	-
TG-082	3,206	152,40	50,80	3,00	6	2	-

TUBOS QUADRADOS

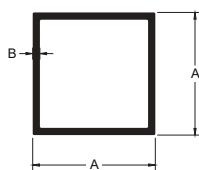

CÓDIGO	PESO (Kg/m)	MILÍMETROS		POLEGADAS	
		A	B	A	B
TQ-023	0,264	25,40	1,00	1	-
TQ-009	0,325	25,40	1,25	1	-
TQ-381	0,441	38,10	1,10	1.1/2	-
TQ-014	0,625	38,10	1,58	1.1/2	1/16
TQ-508	0,697	50,80	1,30	2	-
TQ-509	0,801	50,80	1,50	2	-
TQ-510	0,905	50,80	1,70	2	-
TQ-017	1,047	50,80	1,98	2	-
TQ-206	1,333	63,50	2,00	2.1/2	-
TQ-034	2,687	101,60	2,50	4	-

TUBOS QUADRADOS COM CANTOS ARREDONDADOS

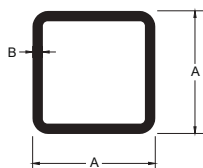

CÓDIGO	PESO (Kg/m)	MILÍMETROS		POLEGADAS	
		A	B	A	B
TQ-501	0,288	19,05	1,59	3/4	1/16
TQ-506	0,397	25,40	1,59	1	1/16

PERFIL U ABAS IGUAIS

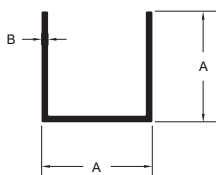

CÓDIGO	PESO (Kg/m)	MILÍMETROS		POLEGADAS	
		A	B	A	B
PU-001	0,109	9,53	1,59	3/8	1/16
PU-102	0,116	12,70	1,20	1/2	-
PU-002	0,150	12,70	1,59	1/2	1/16
PU-104	0,147	15,88	1,20	5/8	-
PU-004	0,192	15,88	1,58	5/8	1/16

PERFIL U ABAS DESIGUAIS

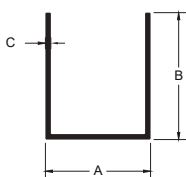

CÓDIGO	PESO (Kg/m)	MILÍMETROS			POLEGADAS		
		A	B	C	A	B	C
PU-344	0,219	15,00	25,00	1,30	-	-	-
PU-210	0,253	25,40	12,70	2,00	1	1/2	-
PU-639	0,390	29,00	35,00	1,50	-	-	-
HD-001	0,904	51,00	60,00	2,00	-	-	-
HD-003	1,085	84,40	60,00	2,00	-	-	-

PERFIL T

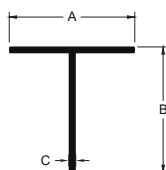

CÓDIGO	PESO (Kg/m)	MILÍMETROS			POLEGADAS		
		A	B	C	A	B	C
PT-008	0,161	25,40	25,40	1,20	1	1	-
PT-009	0,210	25,40	25,40	1,58	1	1	1/16

VERGALHÃO REDONDO

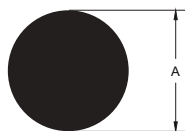

CÓDIGO	PESO (Kg/m)	MILÍMETROS	POLEGADAS
		A	A
VR-005	0,193	9,53	-
VR-015	0,533	15,87	5/8
VR-016	0,772	19,05	3/4
VR-020	1,373	25,40	1

VERGALHÃO QUADRADO

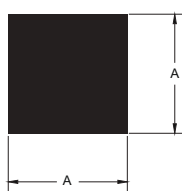

CÓDIGO	PESO (Kg/m)	MILÍMETROS	POLEGADAS
		A	A
VQ-009	1,748	25,40	1
VQ-011	2,731	31,75	1.1/4

código perfil	descrição (perfis de encaixe)	peso (kg/m)	página
CL-006	Conexão	1,100	7.001
CL-011	Cunha	0,333	7.001
CL-007	Conexão	0,933	7.001
CL-046	Cunha	0,333	7.001
CL-009	Conexão	1,600	7.002
CL-044	Conexão	1,067	7.002
CL-010	Cunha	0,400	7.002
CM-200	Contra-Marco	0,200	7.003
CM-210	Contra-Marco	0,246	7.003
Y-721	Contra-Marco	0,217	7.003
CM-060	Contra-Marco	0,283	7.003
CM-047	Contra-Marco	0,283	7.004
CM-211	Contra-Marco	0,475	7.004
CM-174	Contra-Marco	0,417	7.004
MP-347	Arremate	0,200	7.005
CM-048	Arremate	0,167	7.005
E-504	Arremate	0,167	7.005
CM-008	Arremate	0,177	7.005
ME-014	Arremate de piso	0,235	7.006
ME-013	Arremate - Soleira	0,267	7.006
VT-001	Marco Trilho Superior	0,767	7.007
VT-002	Marco Trilho Inferior	0,717	7.007
VT-898	Marco Trilho Inferior	0,780	7.007
VT-260SA	Marco Trilho Inferior	0,633	7.008
VT-004	Marco Travessa Liso	0,500	7.008
VT-005	Travessa Trilho Bandeira	1,117	7.008
VT-843	Travessa Trilho Peitoril	1,030	7.009
VT-006	Travessa Trilho Peitoril	1,083	7.009
VT-260	Marco Trilho Inferior	0,708	7.010
VT-228	Marco Trilho Inferior	0,700	7.010
VT-009	Coluna	0,917	7.010
PV-001	Marco Trilho Superior	0,685	7.011
PV-002	Marco Trilho Inferior	0,597	7.011
PV-004	Marco Trilho Inferior	0,665	7.011
VT-003	Marco Lateral	0,533	7.012
VT-007	Marco Lateral	0,383	7.012
PV-003	Marco Lateral	0,473	7.012
VT-010	Marco Trilho Superior	1,033	7.013
VT-011	Marco Trilho Inferior	0,983	7.013
VT-230	Marco Trilho Inferior	0,967	7.013

código perfil	descrição (perfis de encaixe)	peso (kg/m)	página
VT-018	Marco Travessa Liso	0,667	7.014
VT-019	Marco Trilho Bandeira	1,783	7.014
VT-017	Marco Trilho Inferior	0,233	7.015
VT-302	Mata-Junta	0,283	7.015
VT-013	Marco Lateral	0,783	7.015
VT-014	Marco Lateral	0,683	7.015
VT-012	Marco Lateral	0,550	7.016
VT-036	Marco Macho e Fêmea	0,467	7.016
VT-053	Folha Travessa	0,517	7.016
VT-227	Folha Travessa Intermediária	0,550	7.016
VT-225	Folha Travessa Inferior	1,000	7.017
VT-044	Folha Montante Lateral	0,978	7.017
VT-039	Folha Montante Lateral	0,533	7.017
VT-250	Folha Montante Lateral	0,736	7.017
VT-040	Folha Montante Mão-Amigo	0,483	7.018
VT-041	Folha Montante Mão-Amigo	0,500	7.018
VT-047	Folha Montante Mão-Amigo	1,043	7.018
VT-049	Folha Montante Mão-Amigo	1,043	7.018
VT-844	Folha Montante Lateral	1,032	7.019
VT-847	Folha Montante Mão-Amigo	1,035	7.019
VT-849	Folha Montante Mão-Amigo	1,028	7.019
VT-042	Folha Montante Mão-Amigo	0,567	7.020
VT-280	Folha Montante Lateral	1,006	7.020
VT-245	Folha Montante Lateral	0,688	7.020
VT-243	Folha Montante Mão-Amigo	0,712	7.020
VT-242	Folha Montante Mão-Amigo	0,743	7.020
VT-186	Folha Travessa	0,517	7.021
VT-188	Folha Travessa Intermediária	0,600	7.021
VT-226	Folha Travessa Inferior	1,017	7.021
VT-107	Vedação Montante	0,283	7.021
VT-055	Folha Montante Lateral	0,550	7.022
VT-060	Folha Montante	0,983	7.022
VT-056	Folha Montante Mão-Amigo	0,550	7.022
VT-061	Folha Montante Mão-Amigo	1,067	7.022
VT-897	Folha Montante	1,087	7.023
VT-861	Folha Montante Mão-Amigo	1,038	7.023
VT-899	Folha Montante	0,857	7.023
VT-859	Folha Montante Mão-Amigo	0,631	7.023
VT-057	Folha Montante Mão-Amigo	0,633	7.024
VT-187	Folha Travessa Veneziana	0,517	7.024

código perfil	descrição (perfis de encaixe)	peso (kg/m)	página
VT-068	Folha Montante Lateral Veneziana	0,533	7.024
VT-069	Folha Montante Mão-Amigo Veneziana	0,583	7.024
VT-070	Folha Montante Mão-Amigo Veneziana	0,533	7.024
VT-1070	Veda Montante	0,240	7.024
VT-079	Marco Maxim-Ar	0,350	7.025
VT-379	Marco	0,360	7.025
VT-088	Marco	0,317	7.025
VT-085	Marco Travessa	0,500	7.025
VT-086	Marco Coluna	0,600	7.025
VT-083	Pingadeira	0,150	7.025
VT-080	Folha Travessa Superior 45°	0,367	7.026
VT-082	Folha Travessa	0,383	7.026
VT-084	Pingadeira	0,133	7.026
VT-292	Inversor para Baguete	0,206	7.026
VT-081	Folha Montante Maxim-ar	0,417	7.026
VT-200	Folha Travessa/Montante 45° Maxim-Ar	0,450	7.026
VT-091	Folha Travessa Superior 45°	0,400	7.027
VT-090	Folha Travessa/Montante 45° Maxim-Ar	0,487	7.027
VT-900	Folha Travessa/Montante 45° Maxim-Ar	0,494	7.027
VT-108	Complemento Veneziana	0,150	7.027
VT-102	Baguete	0,117	7.027
VT-103	Baguete	0,162	7.027
VT-279	Marco - Porta de Giro	0,565	7.028
VT-479	Marco - Porta de Giro	0,620	7.028
VT-110	Folha Travessa	0,533	7.028
VT-111	Montante - Folha	0,640	7.028
25-548	Mata-Junta	0,283	7.028
TQ-055	Tubo Quadrado	0,300	7.028
VZ-001	Veneziana	0,330	7.029
US-001	Veneziana Usinada	0,330	7.029
VZ-050	Veneziana	0,290	7.029
US-050	Veneziana Usinada	0,290	7.029
ECO-347	Arremate	0,135	7.030

CL-006	Conexão
1,100 kg/m	

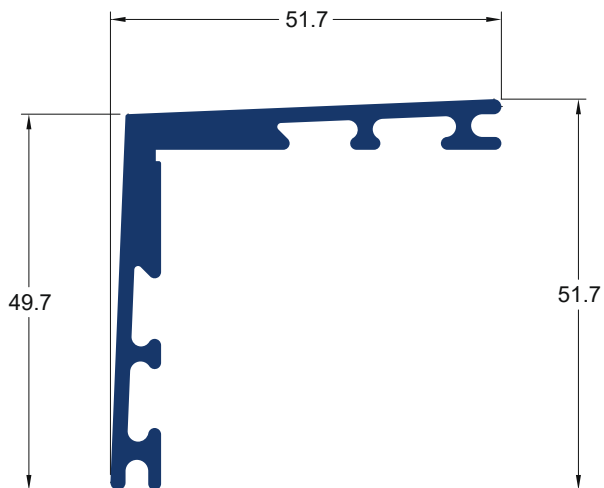

CL-011	Cunha
0,333 kg/m	

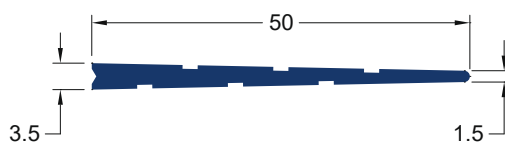

CL-007	Conexão
0,933 kg/m	

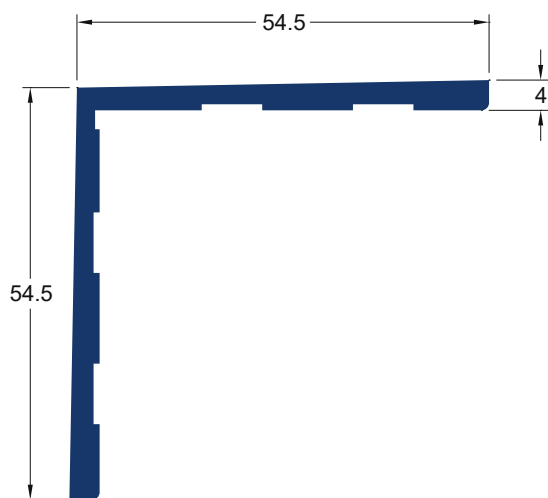

CL-046	Cunha
0,333 kg/m	



CL-009	Conexão
1,600 kg/m	

CL-044	Conexão
1,067 kg/m	

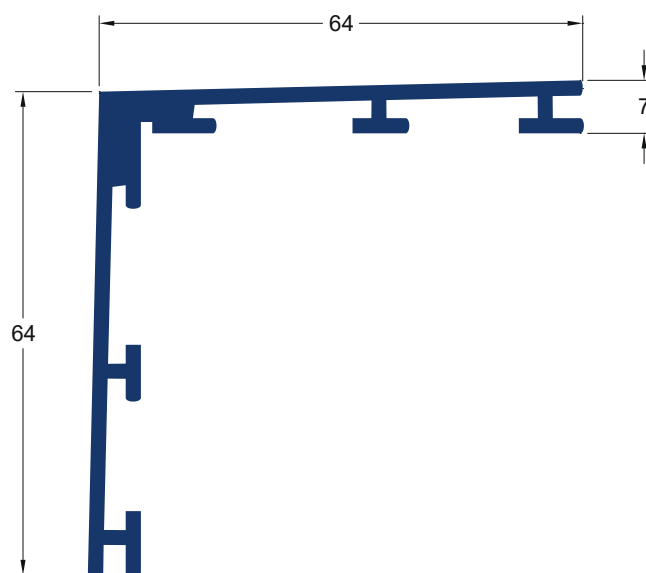
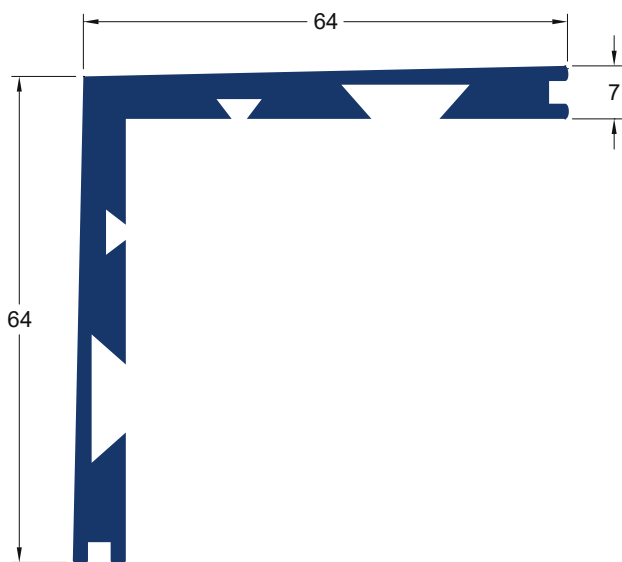

CL-010	Cunha
0,400 kg/m	

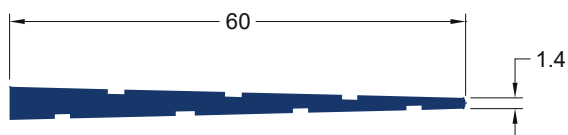

CM-200
0,200 kg/m

Contra-Marco

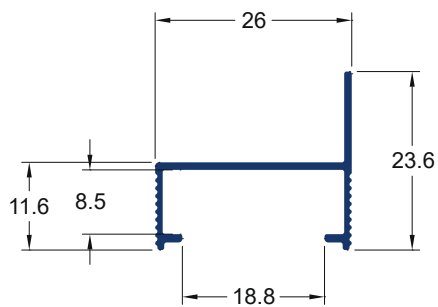

CM-210
0,246 kg/m

Contra-Marco

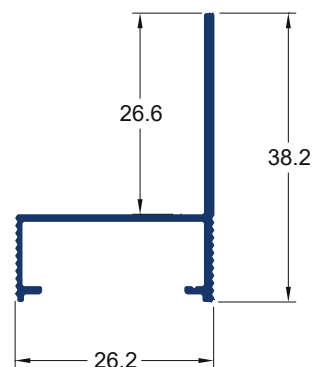

Y-721
0,217 kg/m

Contra-Marco

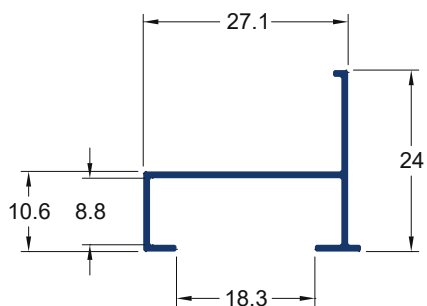

CM-060
0,283 kg/m

Contra-Marco

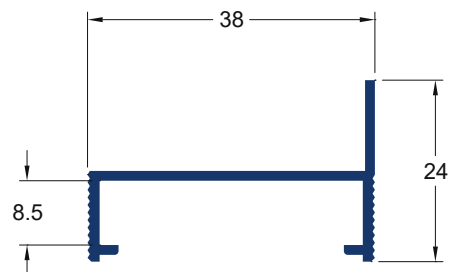

CM-047
0,283 kg/m

Contra-Marco

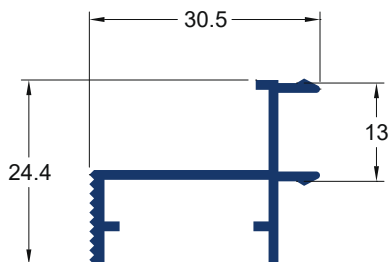

CM-211
0,475 kg/m

Contra-Marco

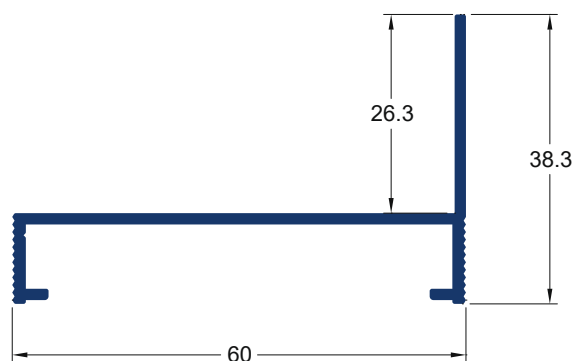

CM-174
0,417 kg/m

Contra-Marco

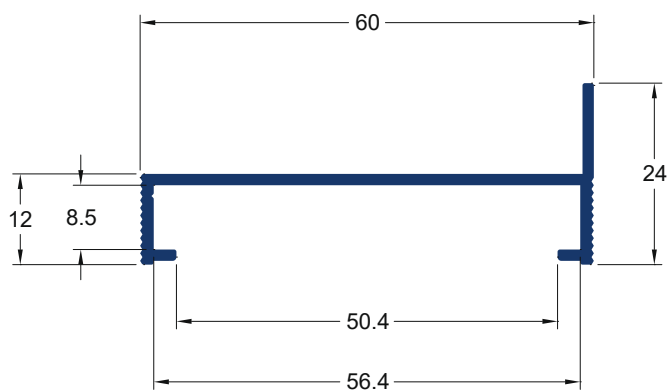

MP-347	Arremate
0,200 kg/m	

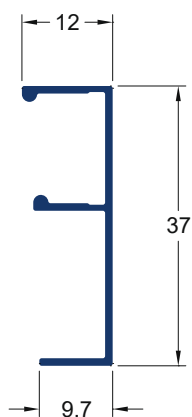

CM-048	Arremate
0,167 kg/m	

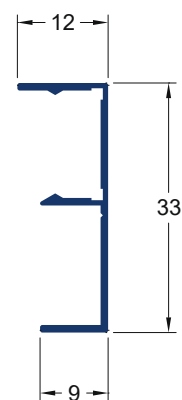

E-504	Arremate
0,167 kg/m	

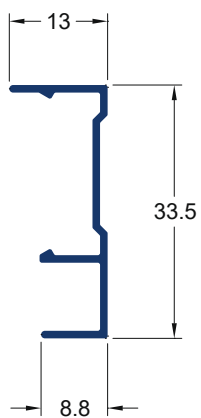

CM-008	Arremate
0,177 kg/m	

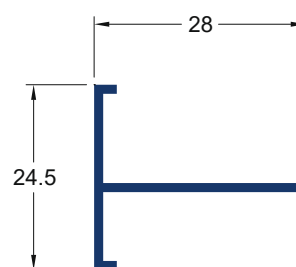

ME-014

0,235 kg/m

Arremate de piso

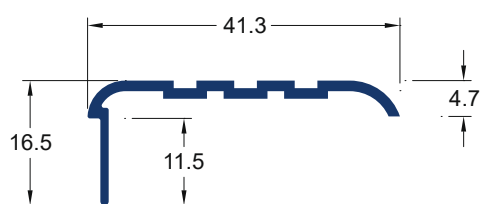

ME-013

0,267 kg/m

Arremate - Soleira

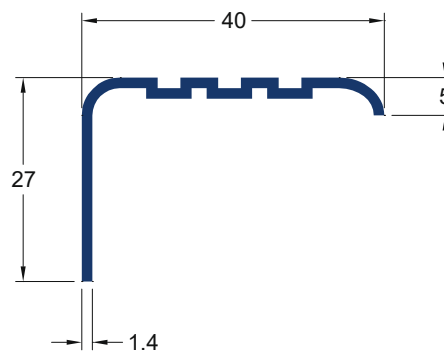

VT-001

0,767 kg/m

Marco Trilho Superior

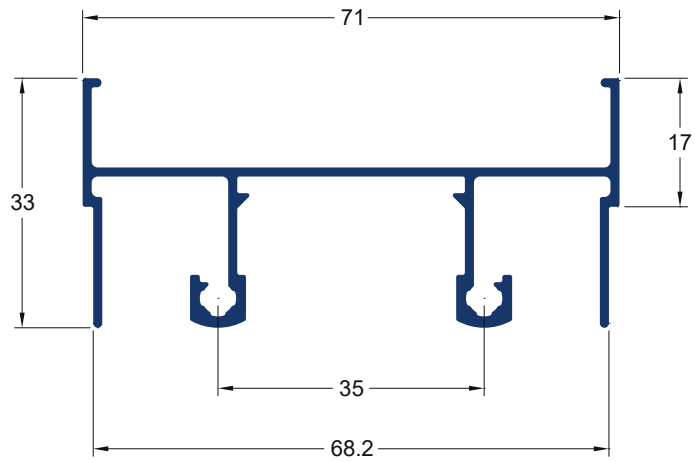
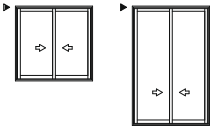

VT-002

0,717 kg/m

Marco Trilho Inferior

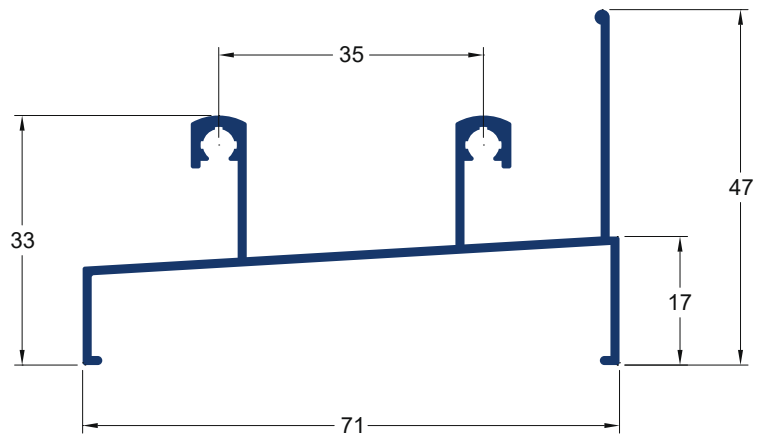

VT-898

0,780 kg/m

Marco Trilho Inferior

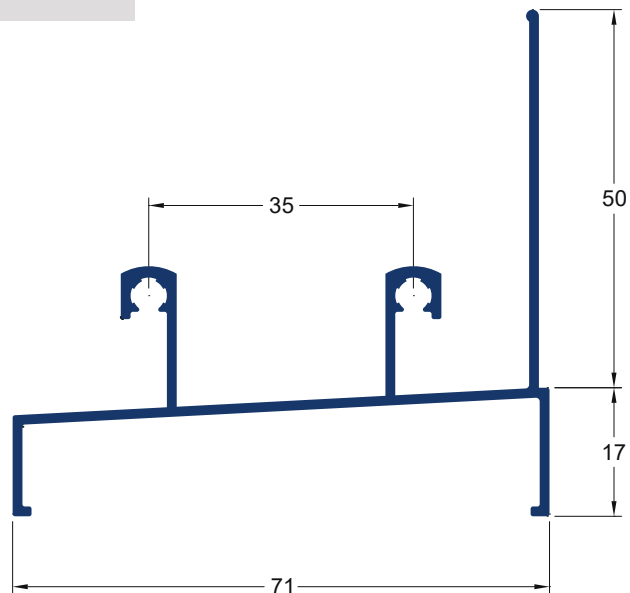

VT-260SA

0,633 kg/m

Marco Trilho Inferior

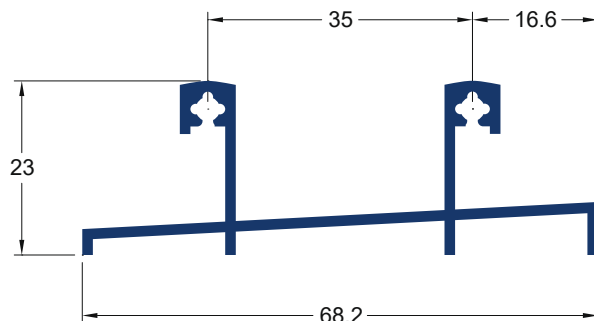

VT-004

0,500 kg/m

Marco Travessa Liso

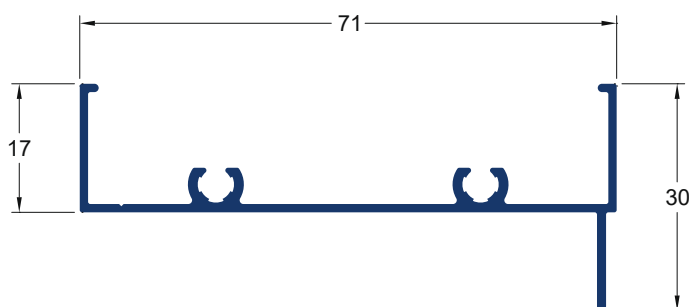
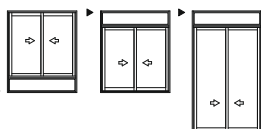

VT-005

1,117 kg/m

Travessa Trilho Bandeira

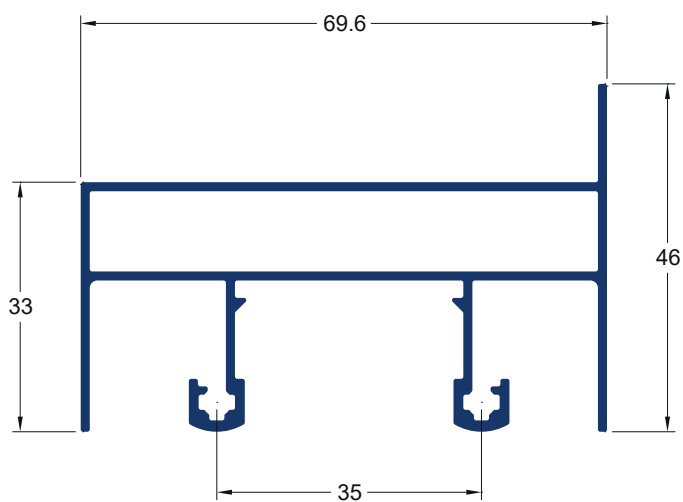
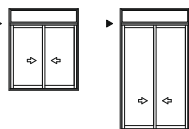

VT-843

1,030 kg/m

Travessa Trilho Peitoril

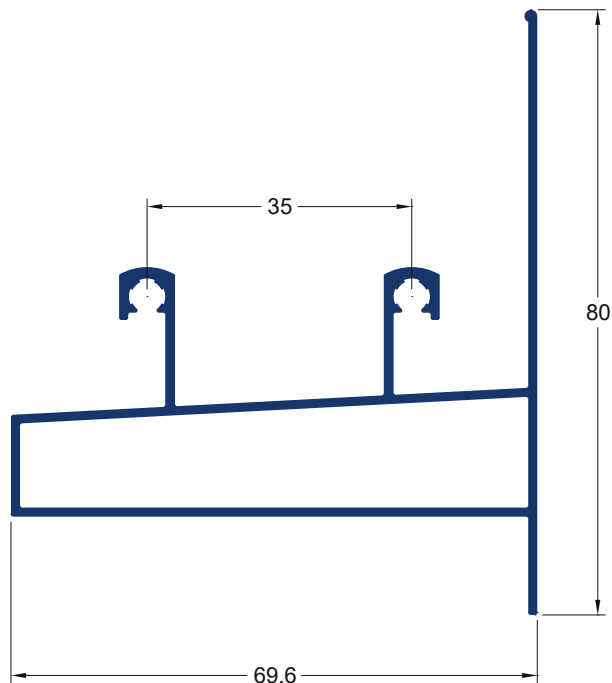

VT-006

1,083 kg/m

Travessa Trilho Peitoril

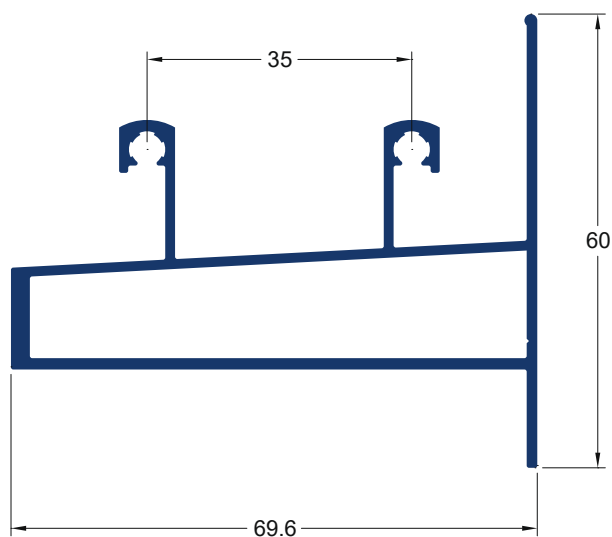

VT-260

0,708 kg/m

Marco Trilho Inferior

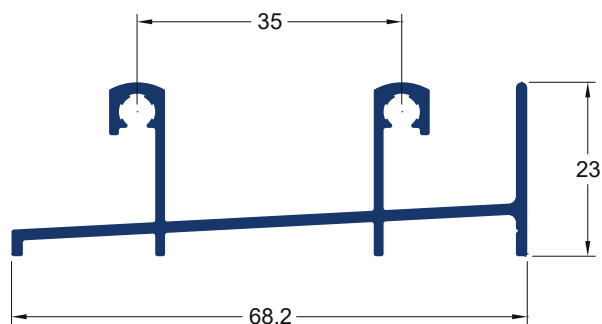

VT-228

0,700 kg/m

Marco Trilho Inferior

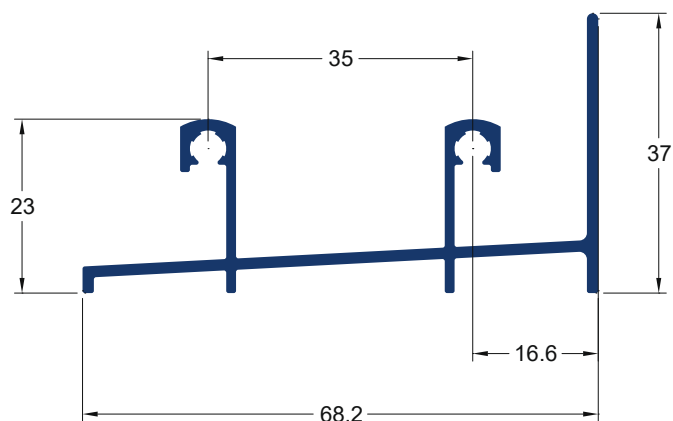
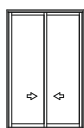

VT-009

0,917 kg/m

Coluna

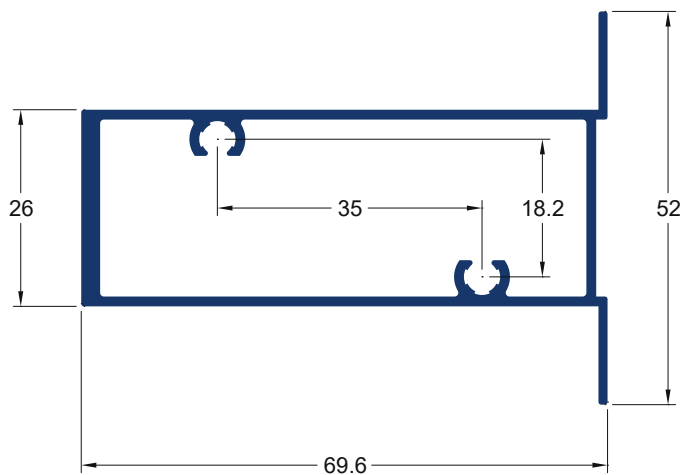
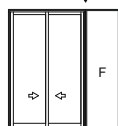

PV-001	Marco Trilho Superior
0,685 kg/m	

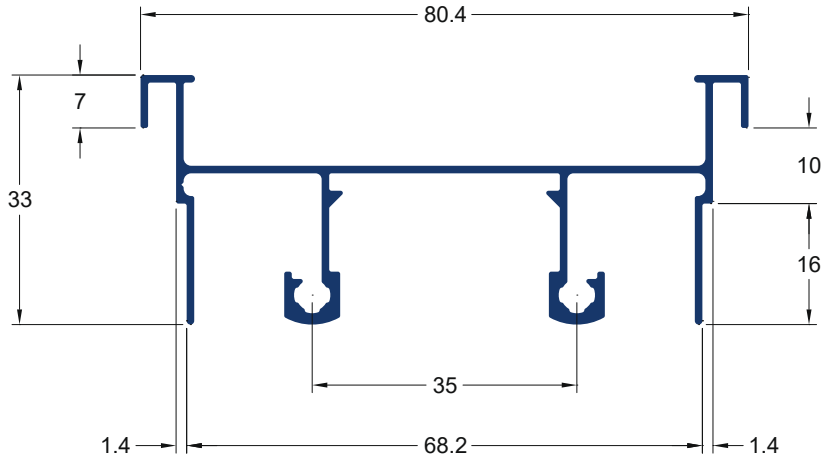
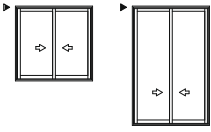

PV-002	Marco Trilho Inferior
0,597 kg/m	

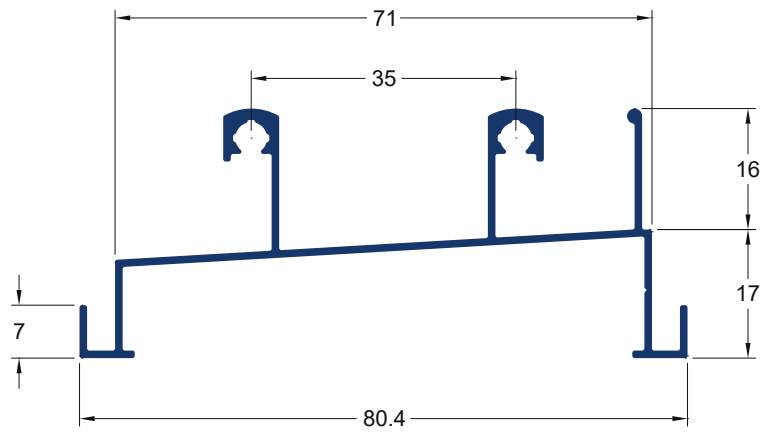

PV-004	Marco Trilho Inferior
0,665 kg/m	

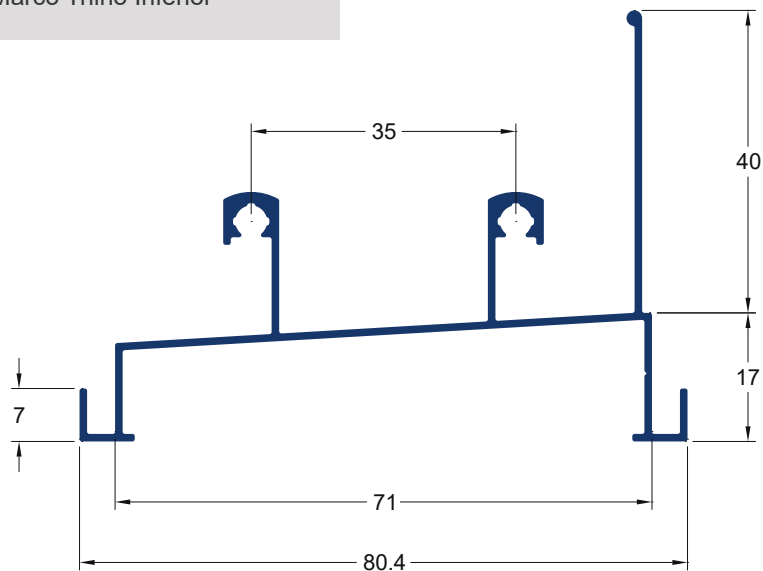

VT-003	Marco Lateral
0,533 kg/m	

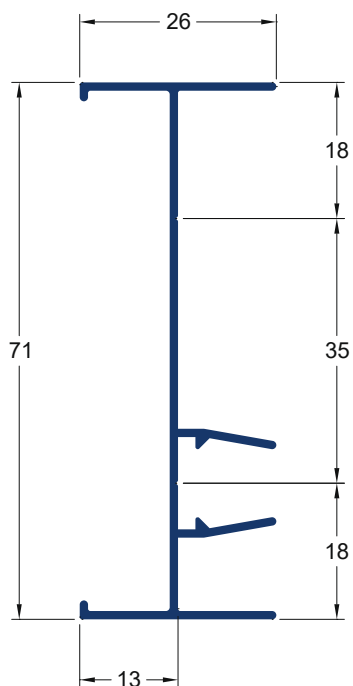
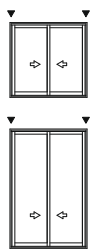

VT-007	Marco Lateral
0,383 kg/m	

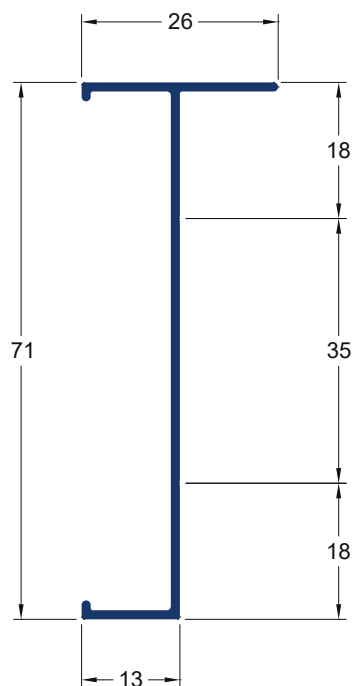
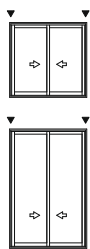

PV-003	Marco Lateral
0,473 kg/m	

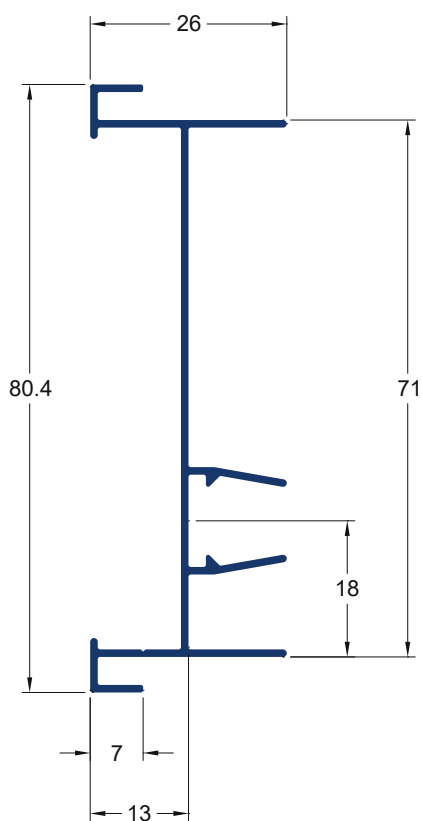
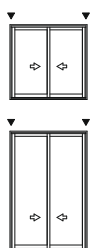

PERFIS, PROJETOS, CÓDIGOS E SISTEMAS ESTÃO SUJEITOS A ALTERAÇÃO SEM AVISO PRÉVIO.

VT-010

1,033 kg/m

Marco Trilho Superior

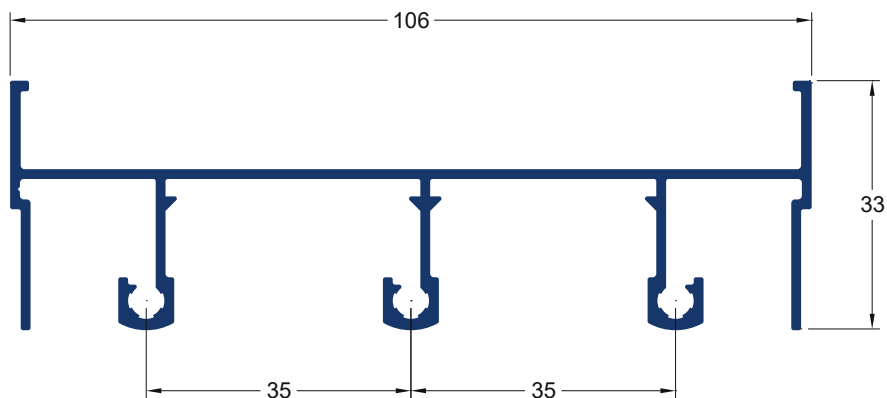

VT-011

0,983 kg/m

Marco Trilho Inferior

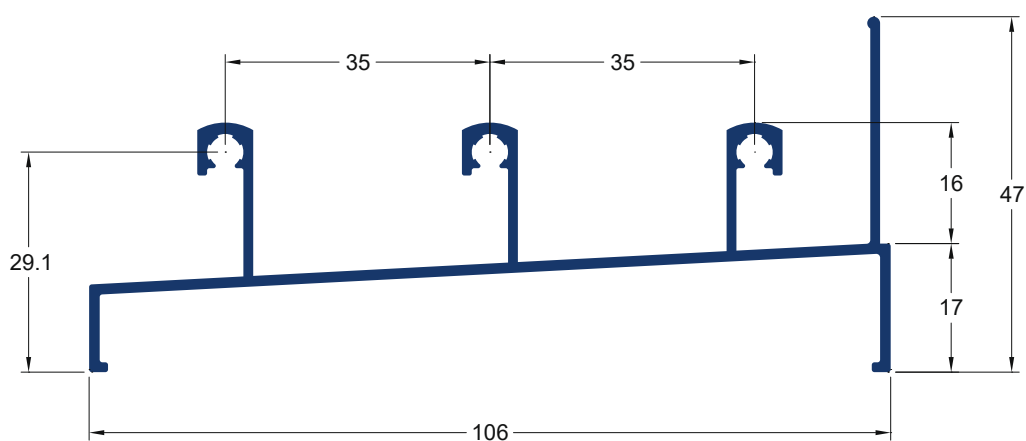
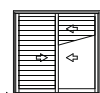

VT-230

0,967 kg/m

Marco Trilho Inferior

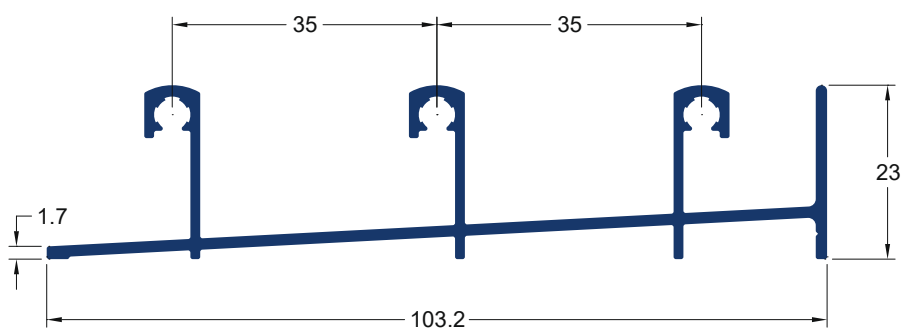
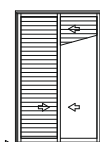

VT-018

0,667 kg/m

Marco Travessa Liso

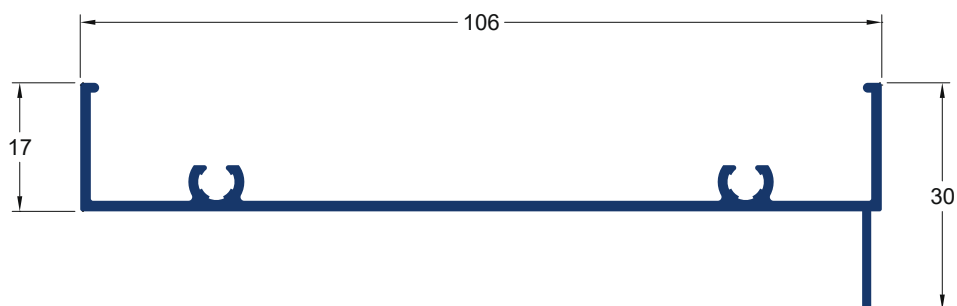
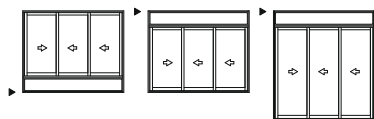

VT-019

1,783 kg/m

Marco Trilho Bandeira

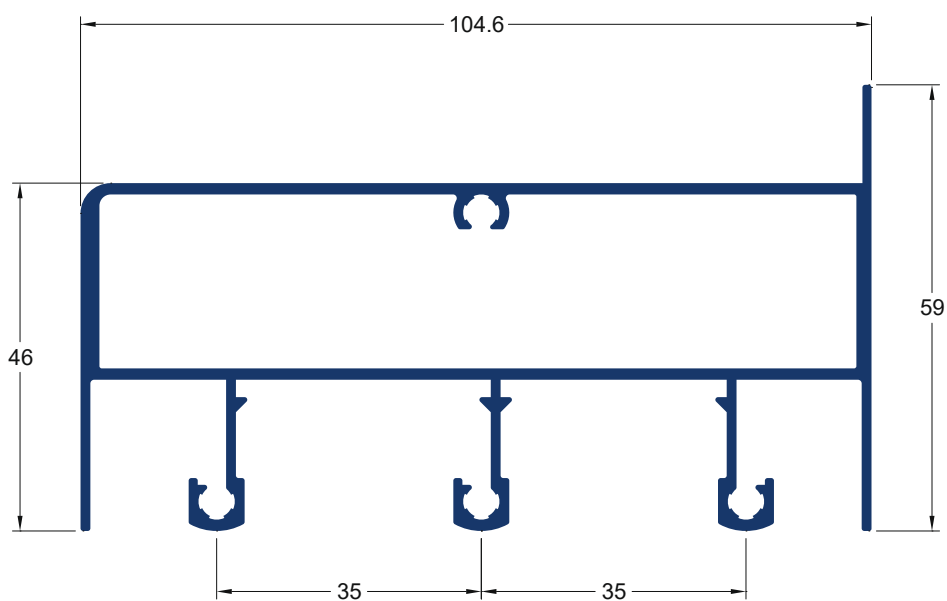
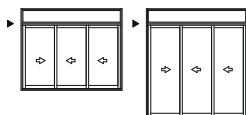

VT-017	Marco Trilho Inferior
0,233 kg/m	

VT-302	Mata-Junta
0,283 kg/m	

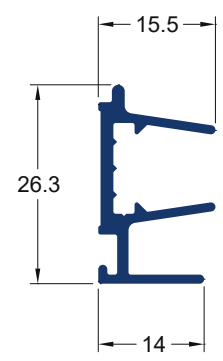
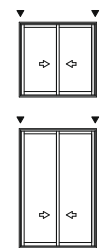
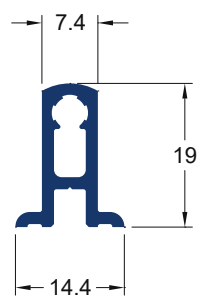

VT-013	Marco Lateral
0,783 kg/m	

VT-014	Marco Lateral
0,683 kg/m	

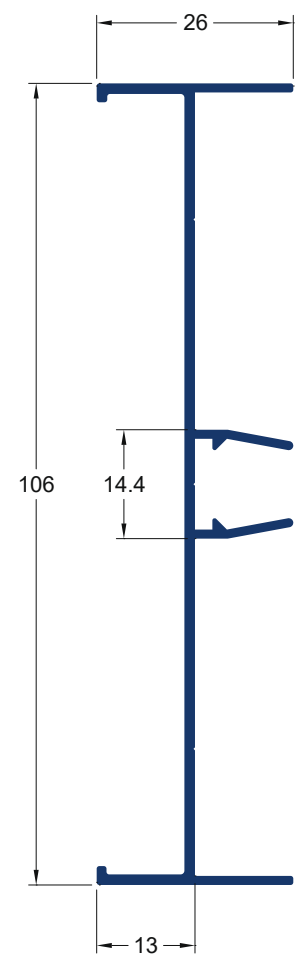
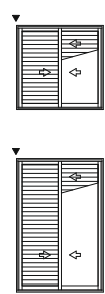
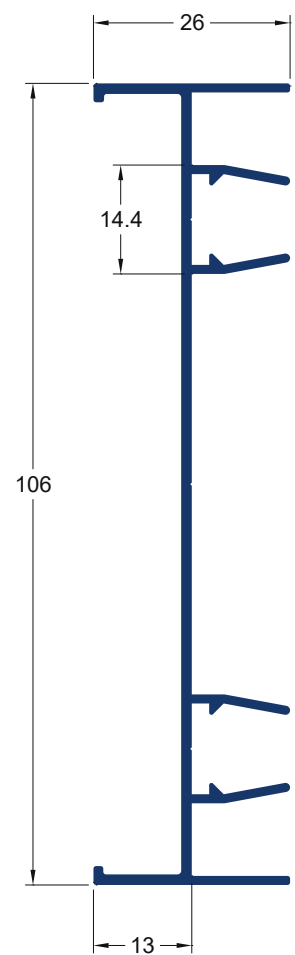
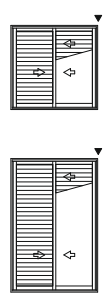

PERFIS, PROJETOS, CÓDIGOS E SISTEMAS ESTÃO SUJEITOS A ALTERAÇÃO SEM AVISO PRÉVIO.

VT-012	Marco Lateral
0,550 kg/m	

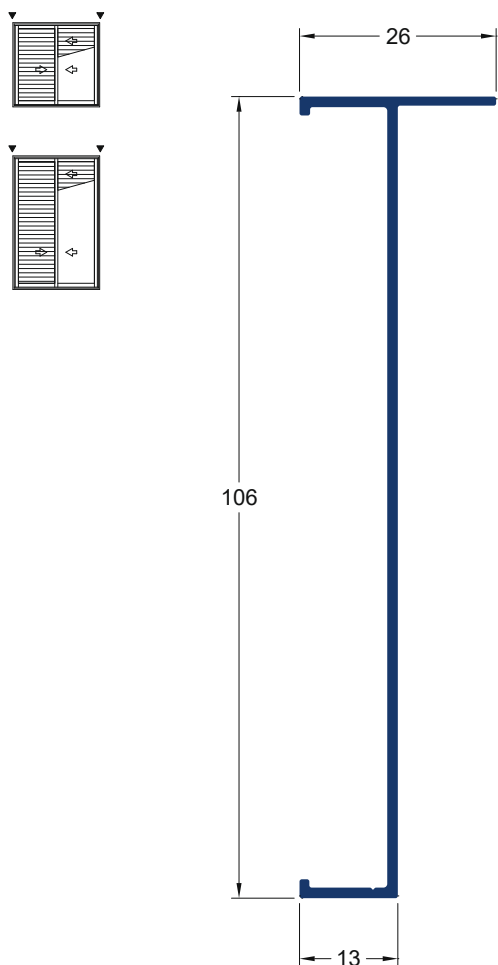

VT-036	Marco Macho e Fêmea
0,467 kg/m	

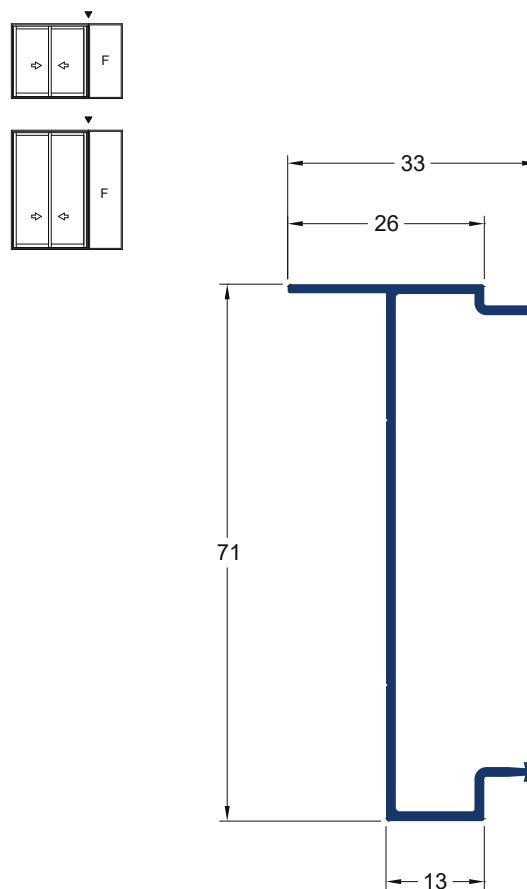

VT-053	Folha Travessa
0,517 kg/m	

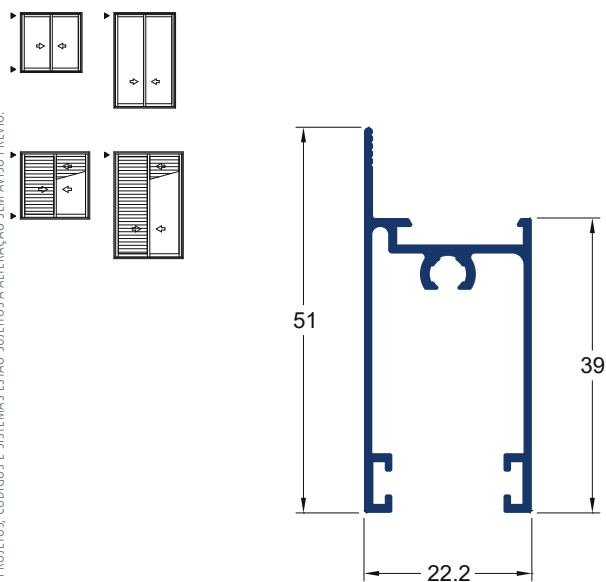

VT-227	Folha Travessa Intermediária
0,550 kg/m	

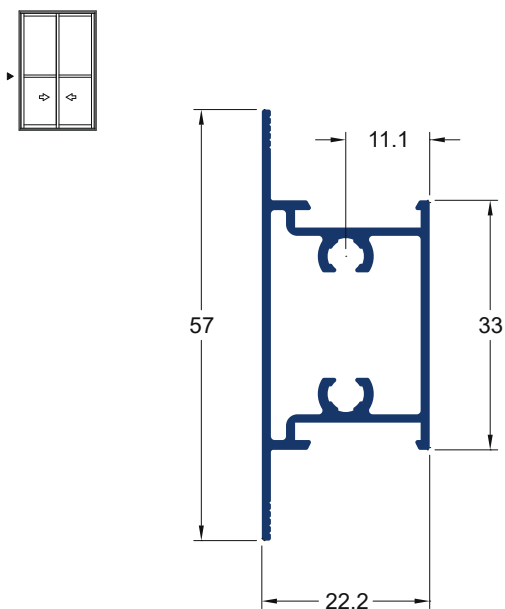

VT-225
 1,000 kg/m
 Folha Travessa Inferior

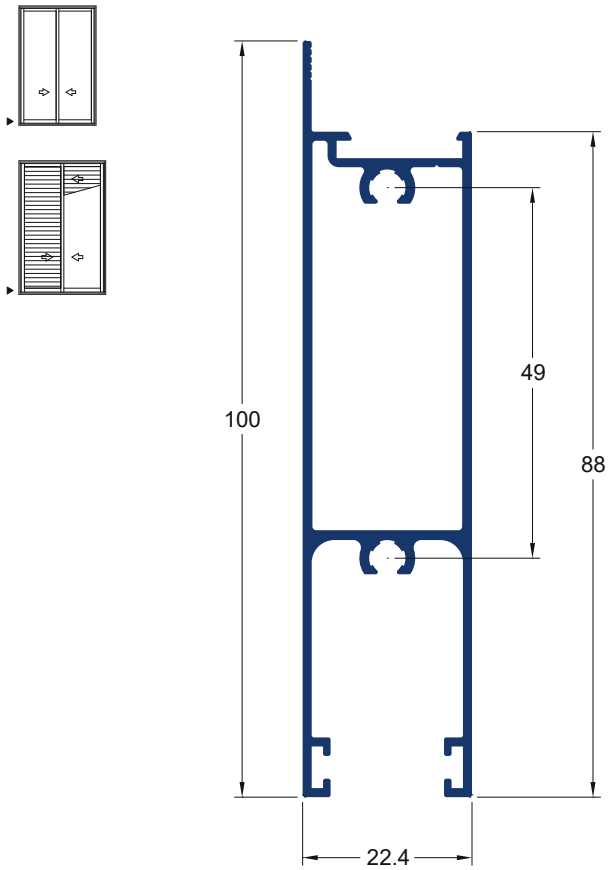

VT-044
 0,978 kg/m
 Folha Montante Lateral

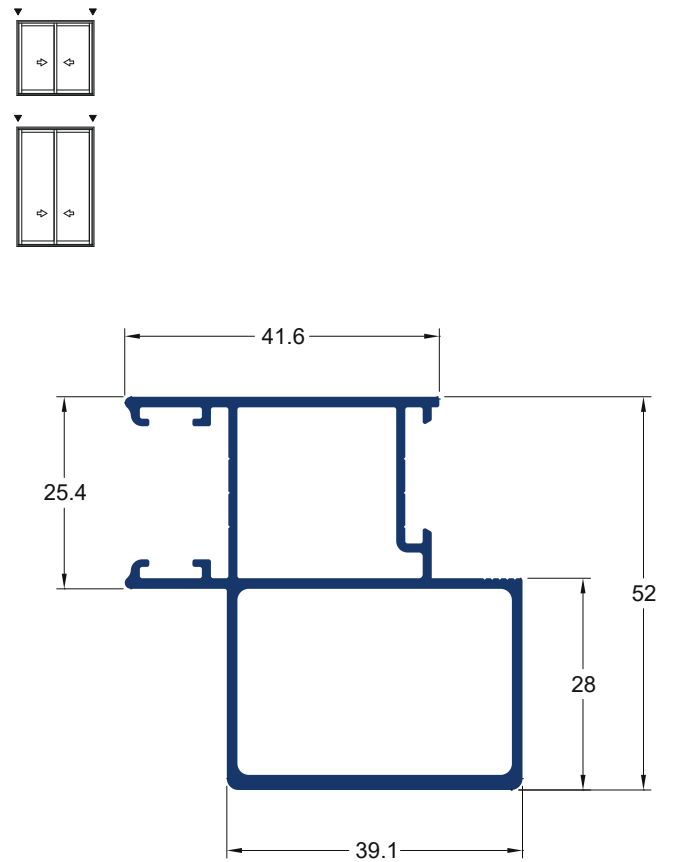

VT-039
 0,533 kg/m
 Folha Montante Lateral

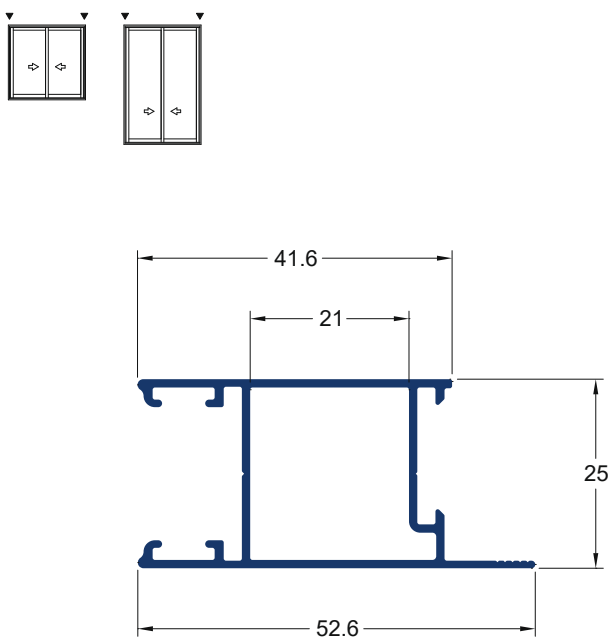

VT-250
 0,736 kg/m
 Folha Montante Lateral

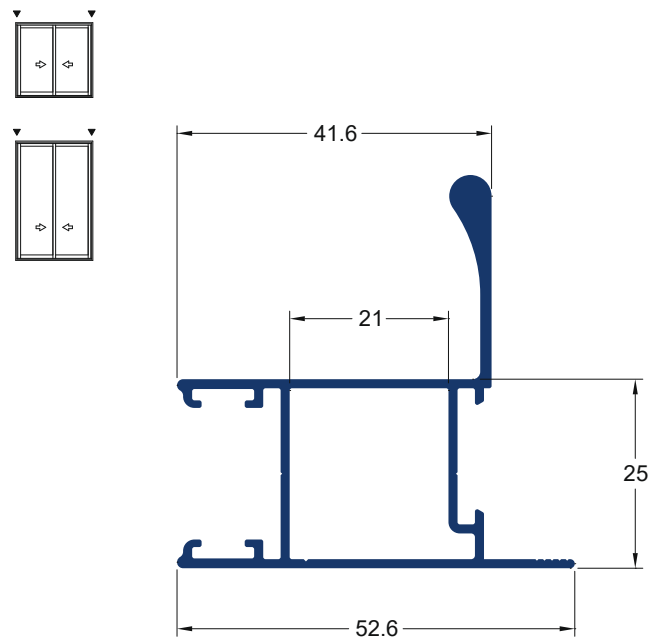

PERFIS, PROJETOS, CÓDIGOS E SISTEMAS ESTÃO SUJEITOS A ALTERAÇÃO SEM AVISO PRÉVIO.

VT-040	Folha Montante Mão-Amigo
0,483 kg/m	

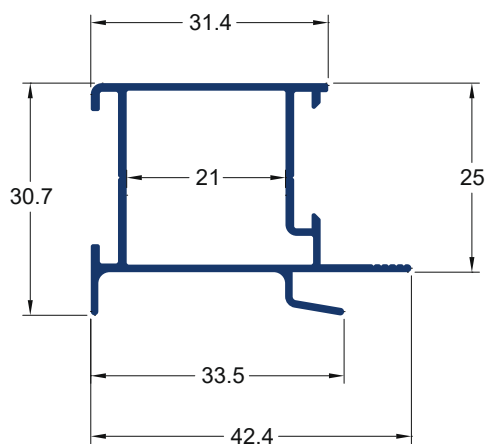

VT-041	Folha Montante Mão-Amigo
0,500 kg/m	

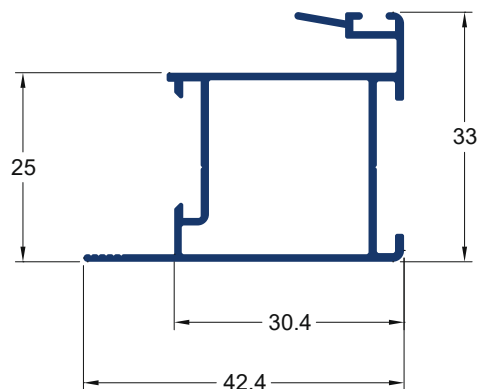

VT-047	Folha Montante Mão-Amigo
1,043 kg/m	

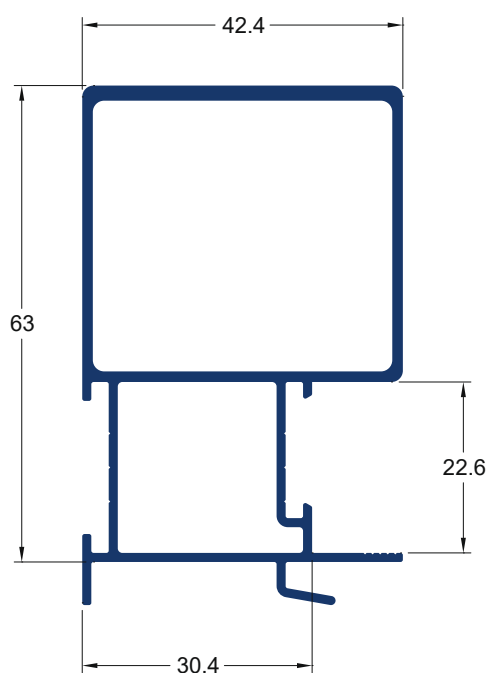
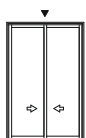

VT-049	Folha Montante Mão-Amigo
1,043 kg/m	

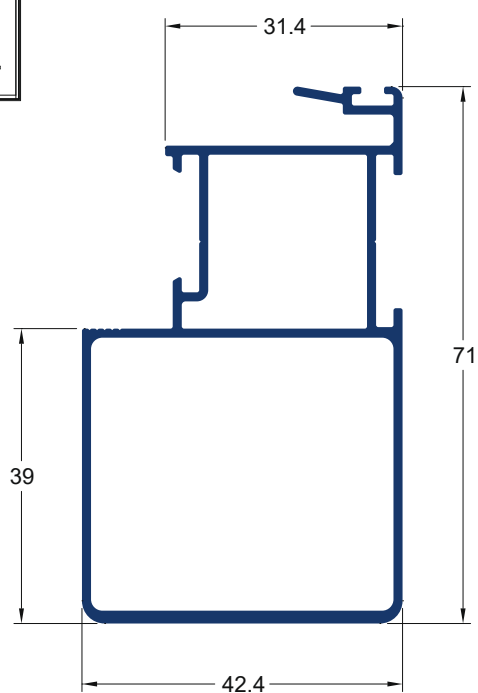
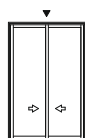

VT-844	Folha Montante Lateral
1,032 kg/m	

VT-847	Folha Montante Mão-Amigo
1,035 kg/m	

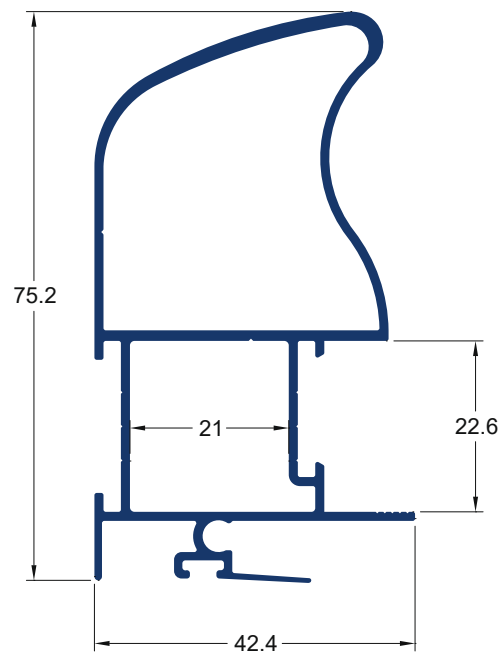
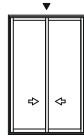
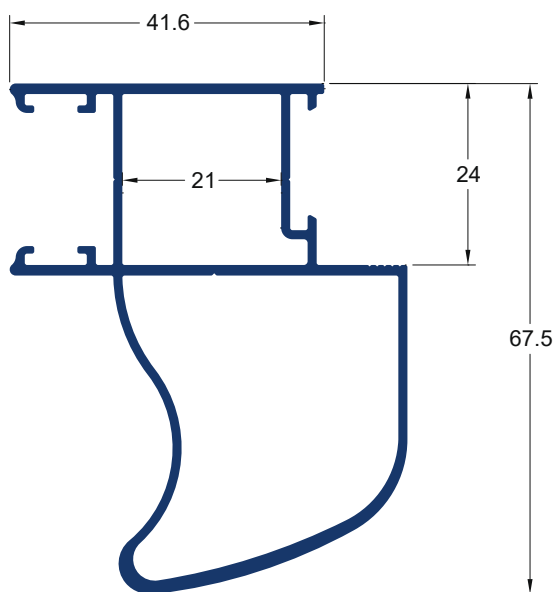
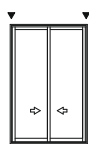

VT-849	Folha Montante Mão de Amigo
1,028 kg/m	

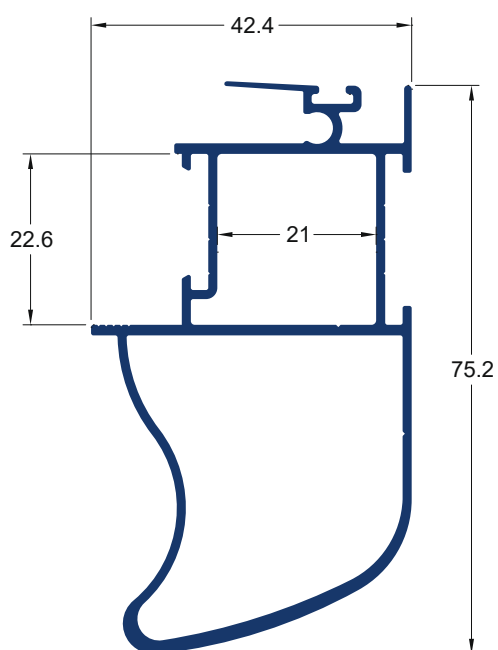
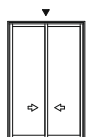

VT-042
0,567 kg/m

Folha Montante Mão-Amigo

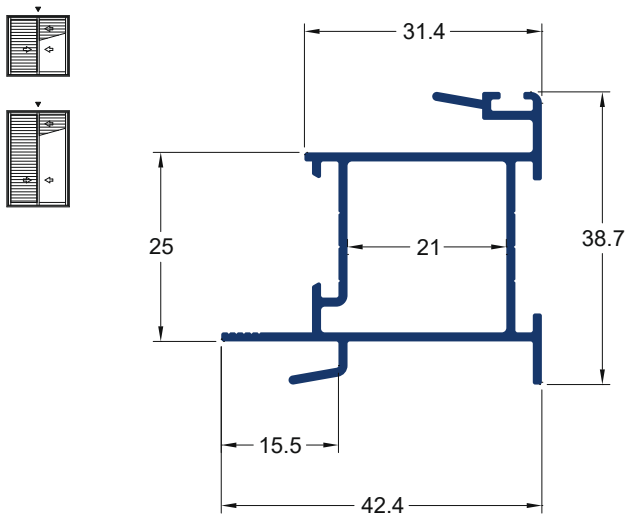

VT-280
1,006 kg/m

Folha Montante Lateral

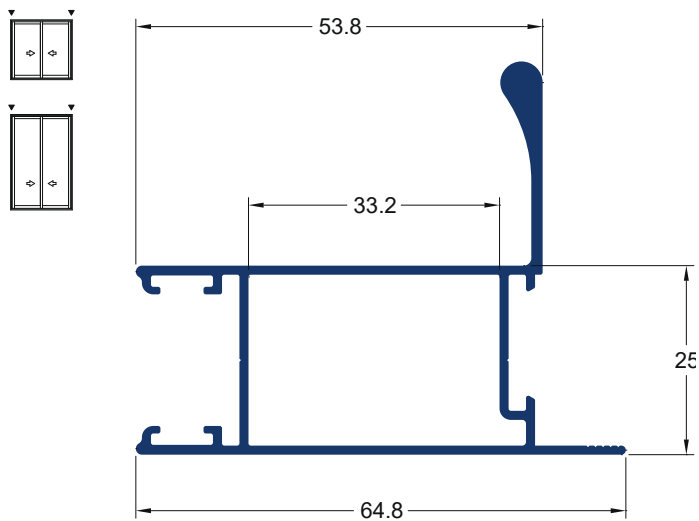

VT-245
0,688 kg/m

Folha Montante Lateral

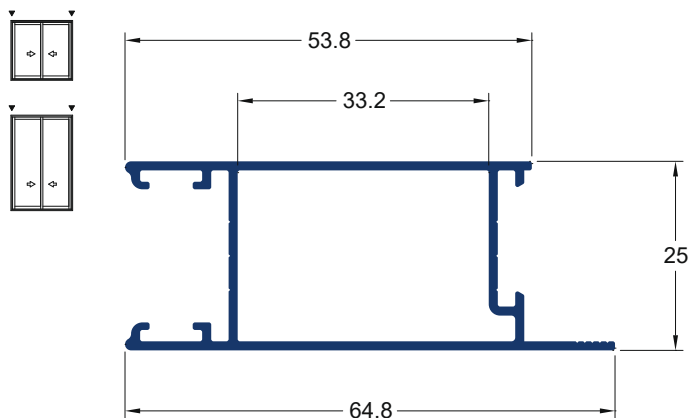

VT-243
0,712 kg/m

Folha Montante Mão-Amigo

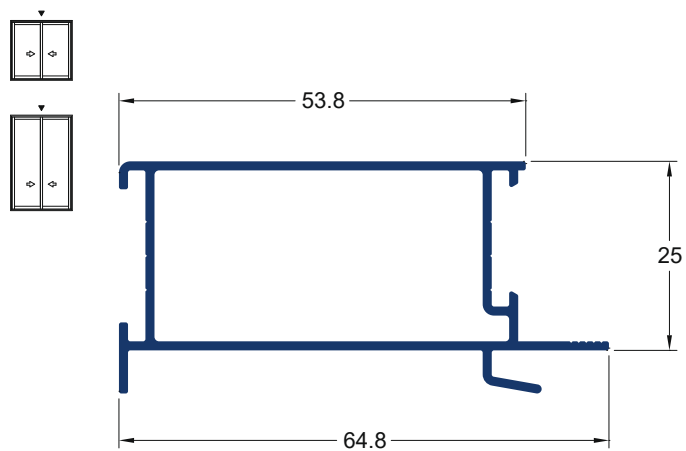

VT-242
0,743 kg/m

Folha Montante Mão-Amigo

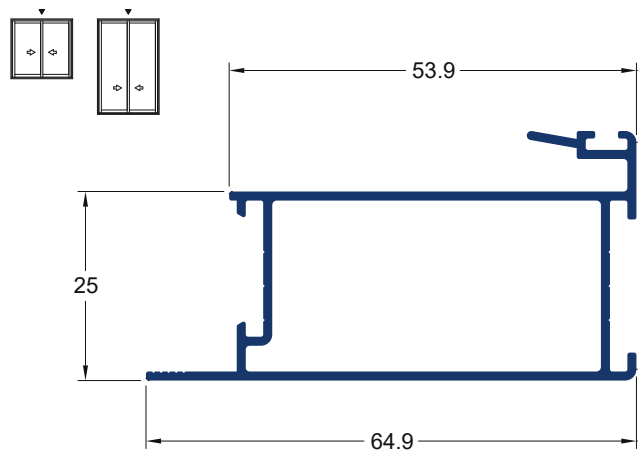

PERFIS, PROJETOS, CÓDIGOS E SISTEMAS ESTÃO SUJEITOS A ALTERAÇÃO SEM AVISO PRÉVIO.

VT-186
 0,517 kg/m
 Folha Travessa

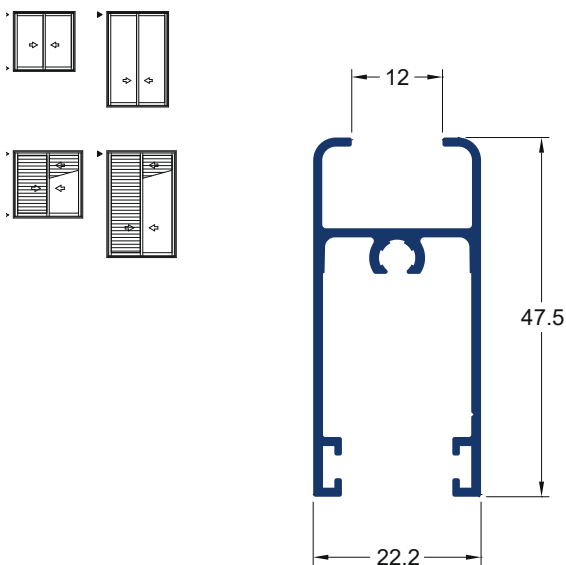

VT-188
 0,600 kg/m
 Folha Travessa Intermediária

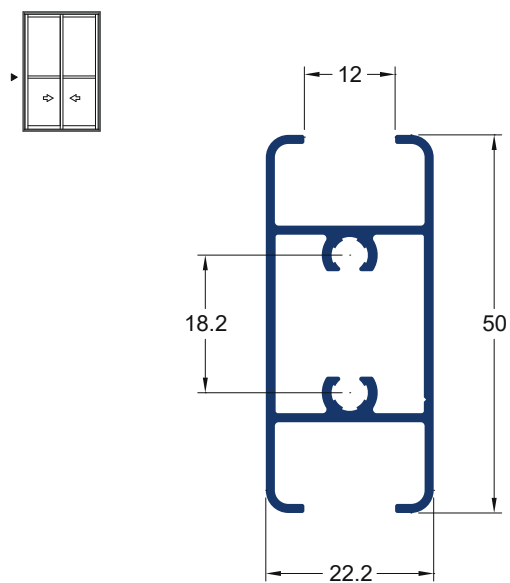

VT-226
 1,017 kg/m
 Folha Travessa Inferior

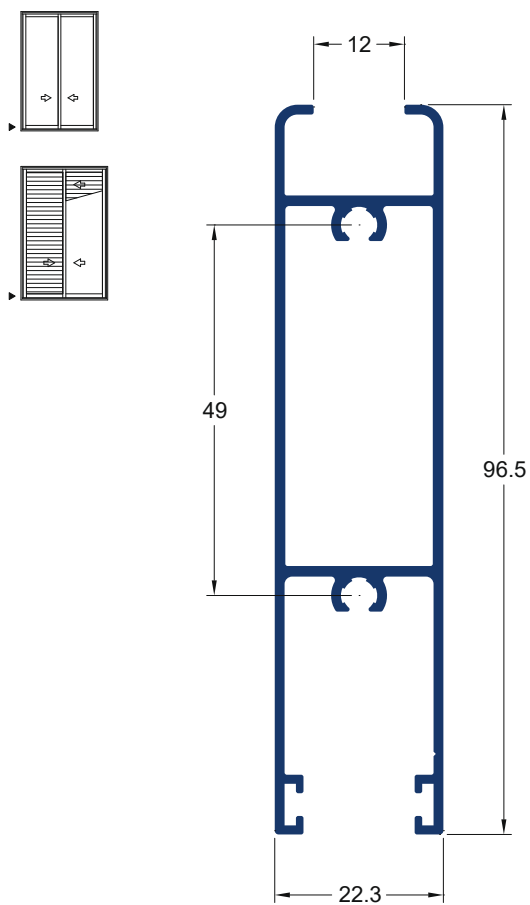

VT-107
 0,283 kg/m
 Vedação Montante

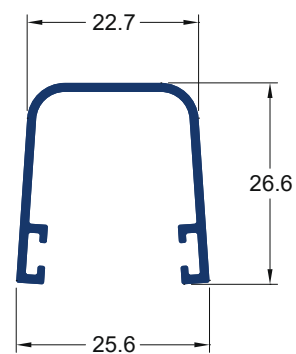

VT-055
0,550 kg/m

Folha Montante Lateral

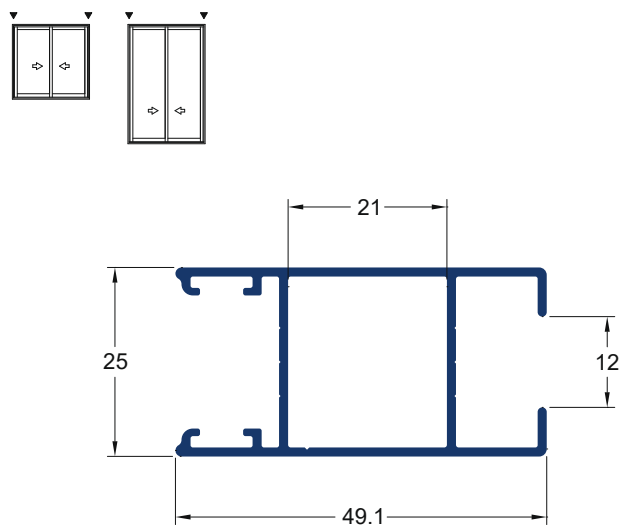

VT-060
0,983 kg/m

Folha Montante

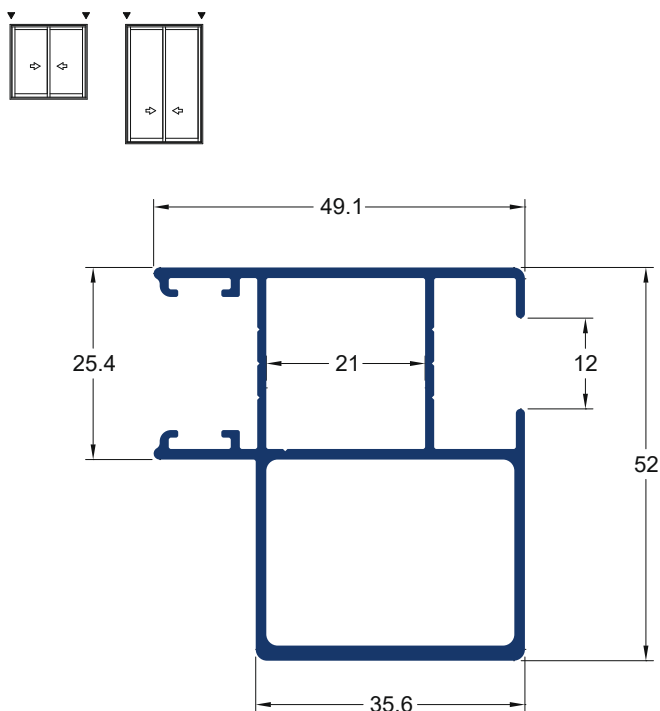

VT-056
0,550 kg/m

Folha Montante Mão-Amigo

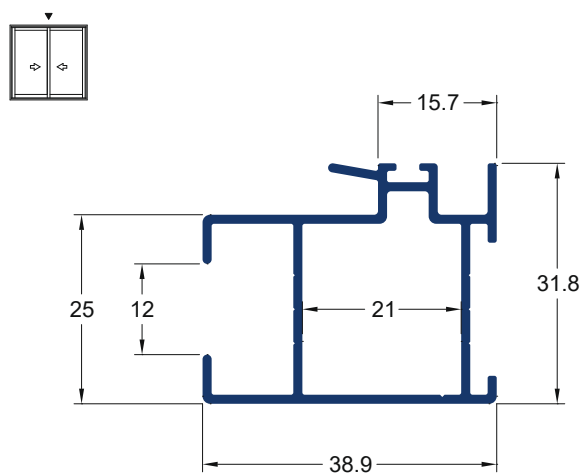

VT-061
1,067 kg/m

Folha Montante Mão-Amigo

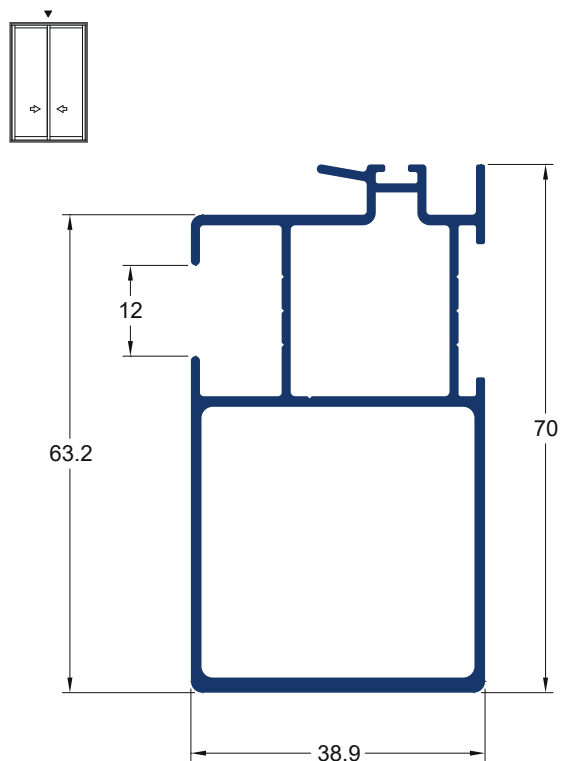

VT-897	Folha Montante
1,087 kg/m	

VT-861	Folha Montante Mão-Amigo
1,038 kg/m	

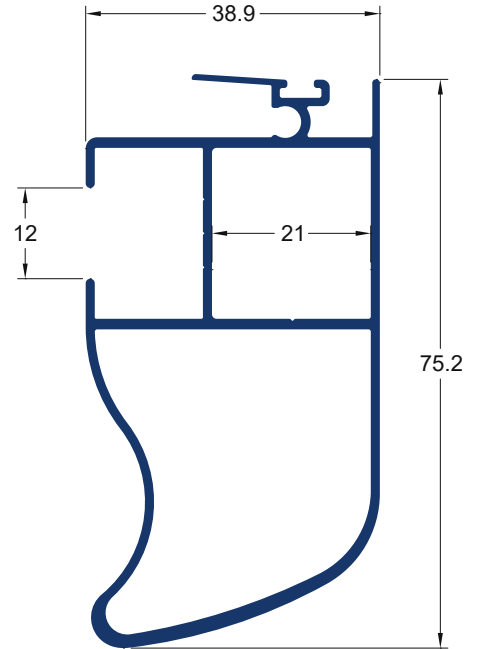
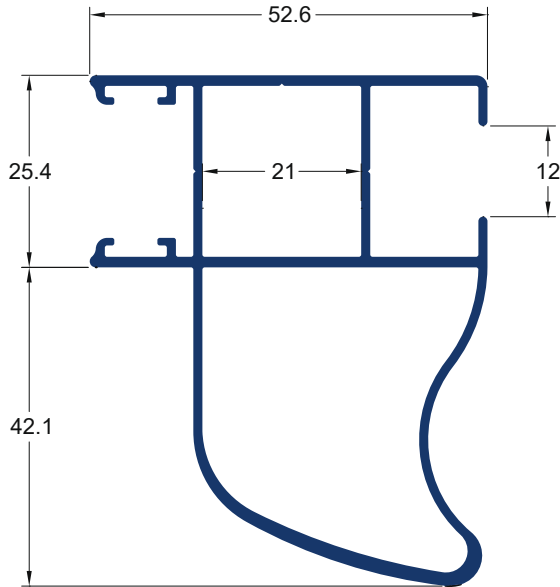
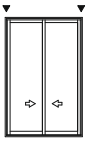

Dados estruturais:
 JX - 19,48

Dados estruturais:
 JX - 21,47

VT-899	Folha Montante
0,857 kg/m	

VT-859	Folha Montante Mão-Amigo
0,631 kg/m	

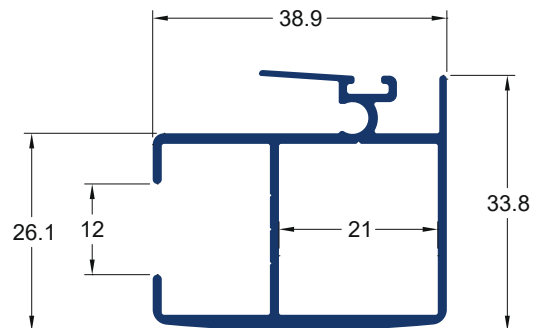
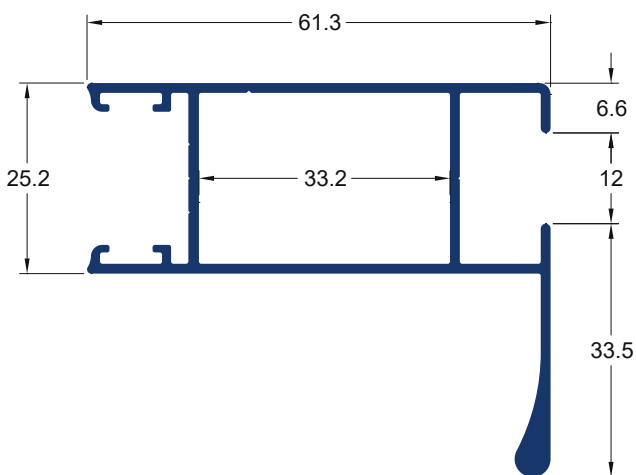
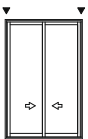

VT-057
0,633 kg/m

Folha Montante Mão-Amigo

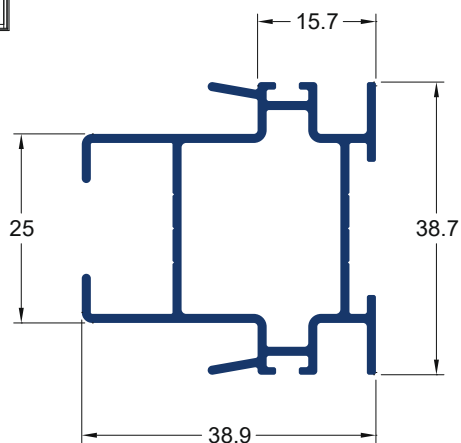
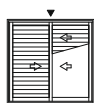

VT-187
0,517 kg/m

Folha Travessa Veneziana

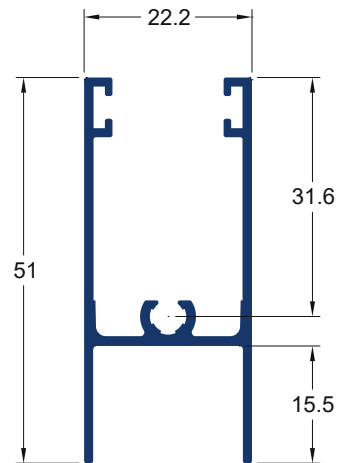
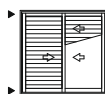

VT-068
0,533 kg/m

Folha Montante Lateral Veneziana

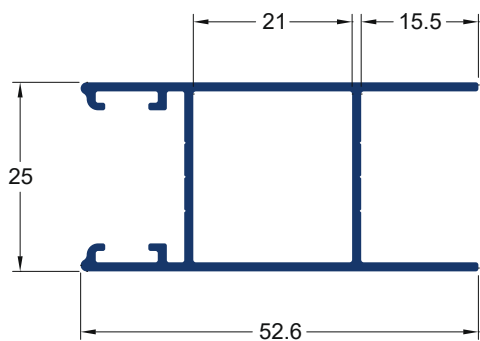
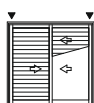

VT-069
0,583 kg/m

Folha Montante Mão-Amigo Veneziana

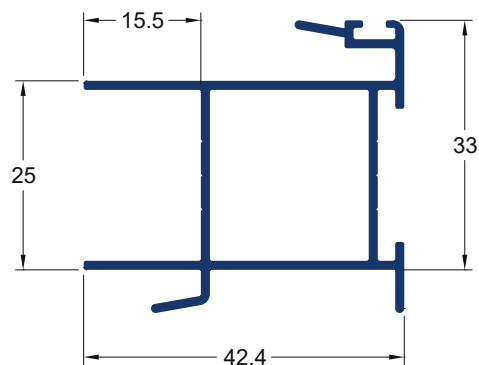
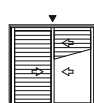

VT-070
0,533 kg/m

Folha Montante Mão-Amigo Veneziana

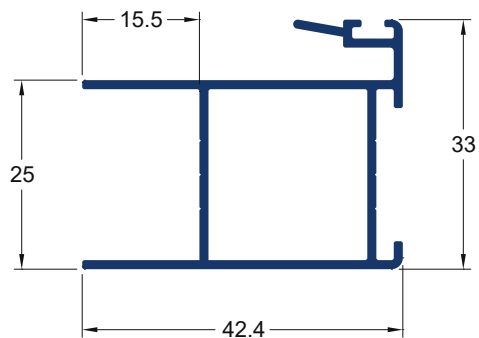
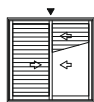

VT-1070
0,240 kg/m

Veda Montante

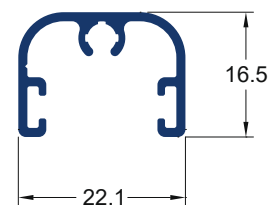
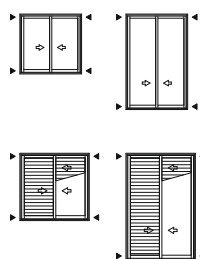

VT-079
 0,350 kg/m
 Marco Maxim-Ar

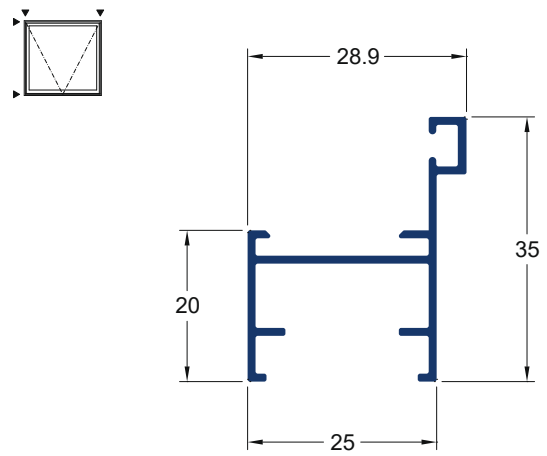

VT-379
 0,360 kg/m
 Marco

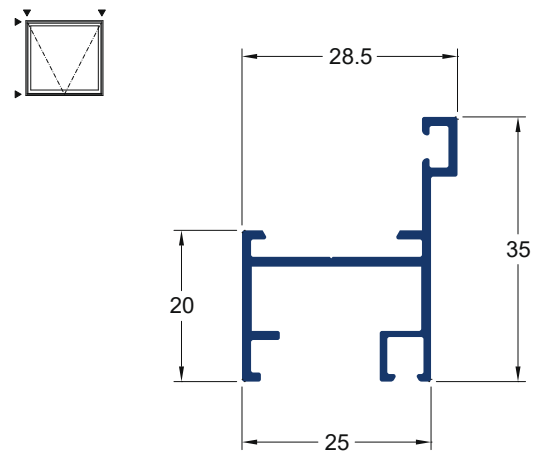

VT-088
 0,317 kg/m
 Marco

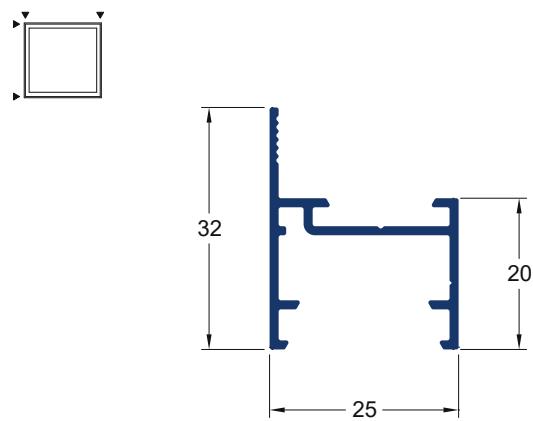

VT-085
 0,500 kg/m
 Marco Travessa

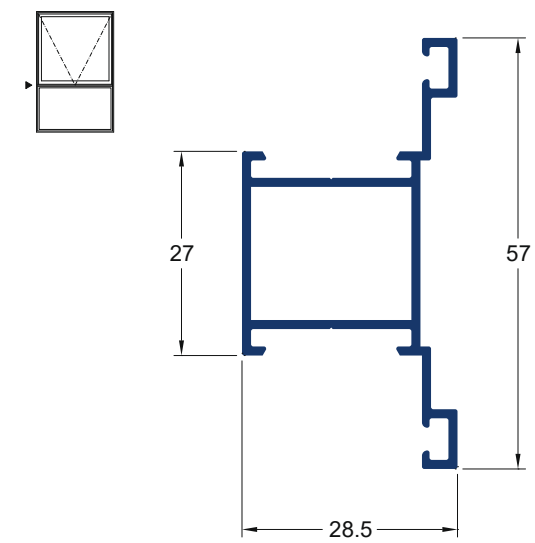

VT-086
 0,600 kg/m
 Marco Coluna

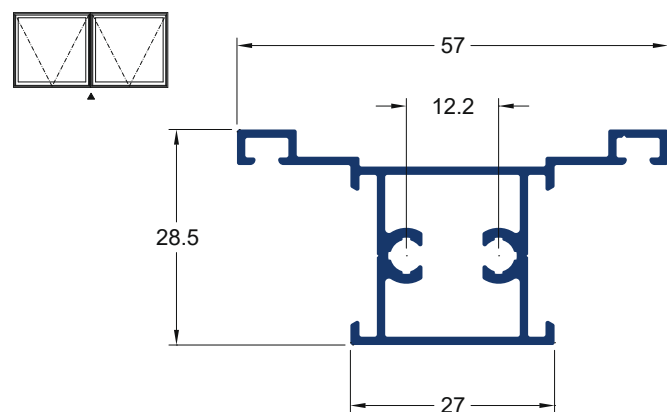

VT-083
 0,150 kg/m
 Pingadeira

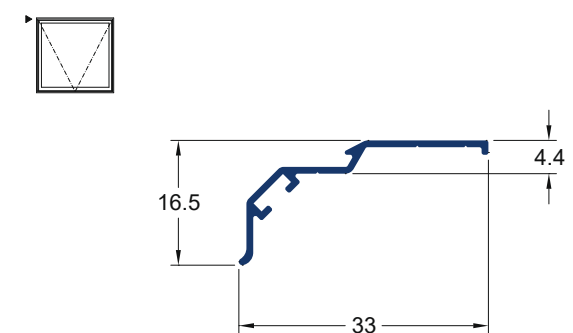

VT-080
0,367 kg/m

Folha Travessa Superior 45°

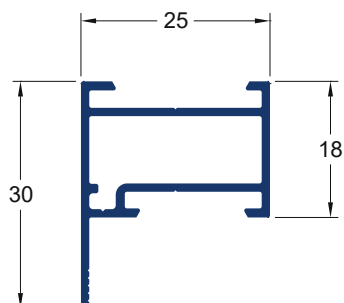

VT-082
0,383 kg/m

Folha Travessa

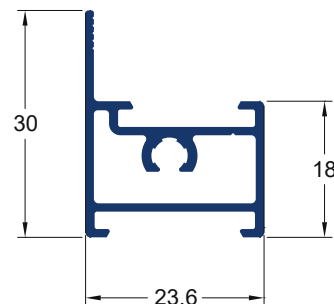

VT-084
0,133 kg/m

Pingadeira

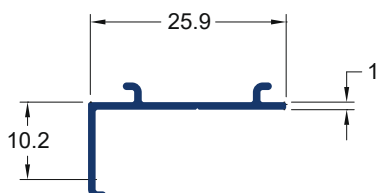
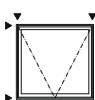

VT-292
0,206 kg/m

Inversor para Baguete

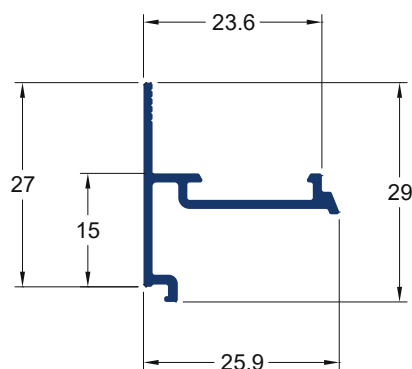
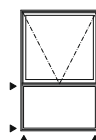

VT-081
0,417 kg/m

Folha Montante Maxim-Ar

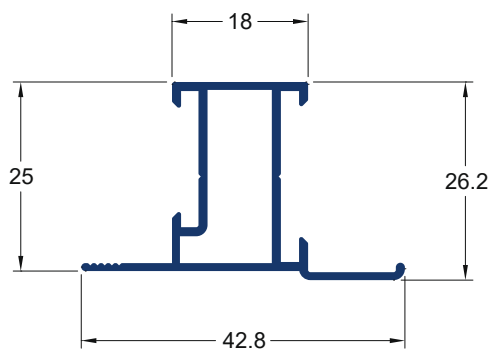
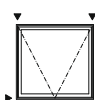

VT-200
0,450 kg/m

Folha Travessa/Montante 45° Maxim-Ar

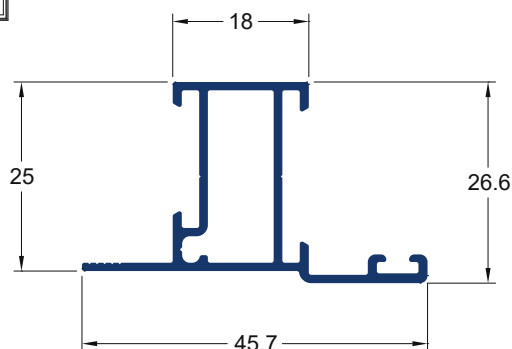
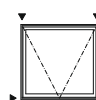

VT-091	Folha Travessa Superior 45°
0,400 kg/m	

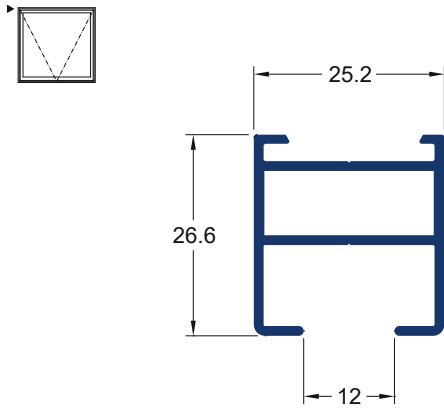

VT-090	Folha Travessa/Montante 45° Maxim-Ar
0,467 kg/m	

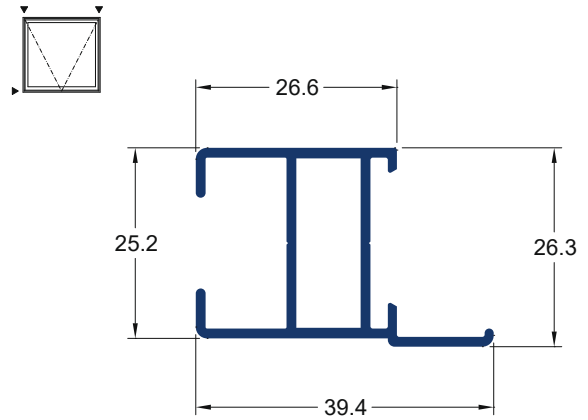

VT-900	Folha Travessa/Montante 45° Maxim-Ar
0,494 kg/m	

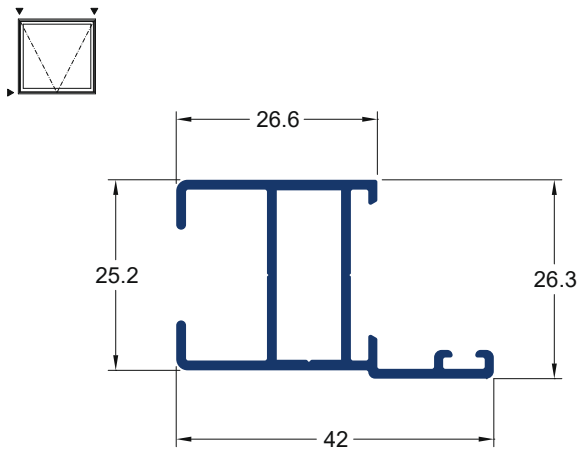

VT-108	Complemento Veneziana
0,150 kg/m	

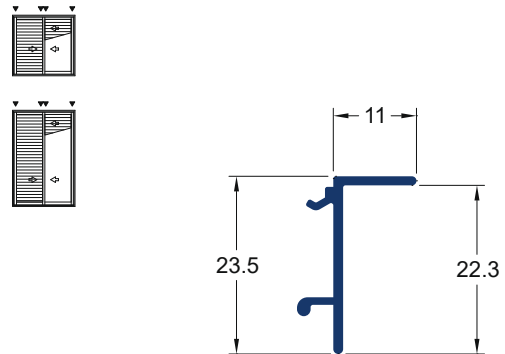

VT-102	Baguete
0,117 kg/m	

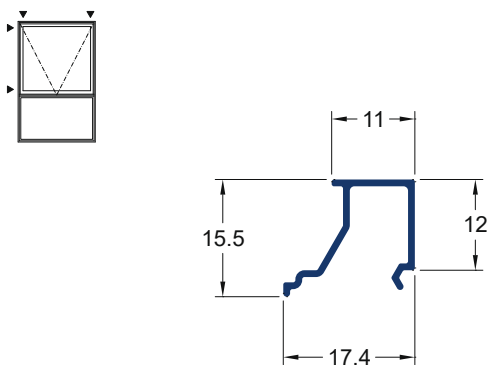

VT-103	Baguete
0,162 kg/m	

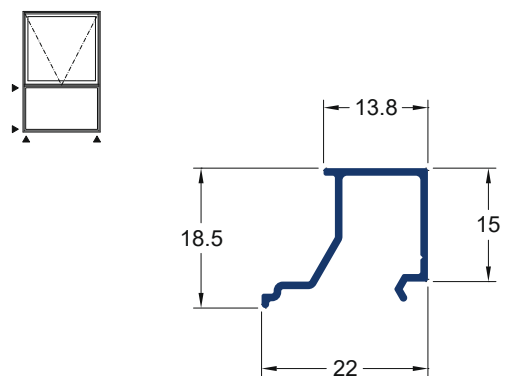

VT-279	Marco - Porta de Giro
0,565 kg/m	

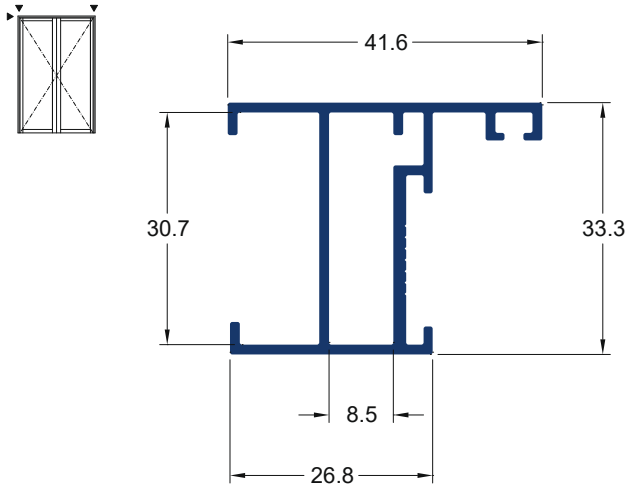

VT-479	Marco - Porta de Giro
0,620 kg/m	

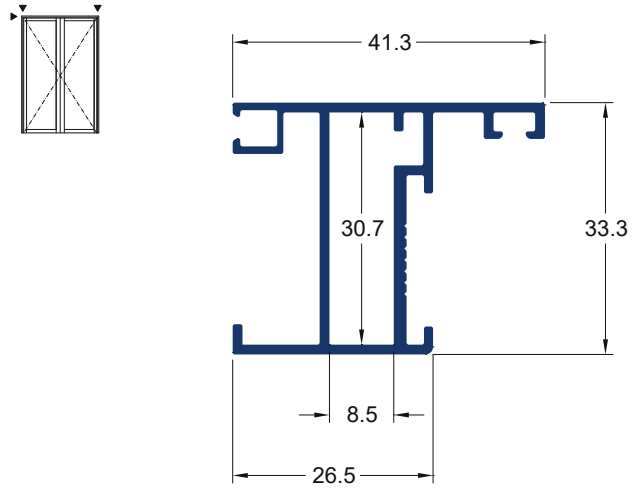

VT-110	Folha Travessa
0,533 kg/m	

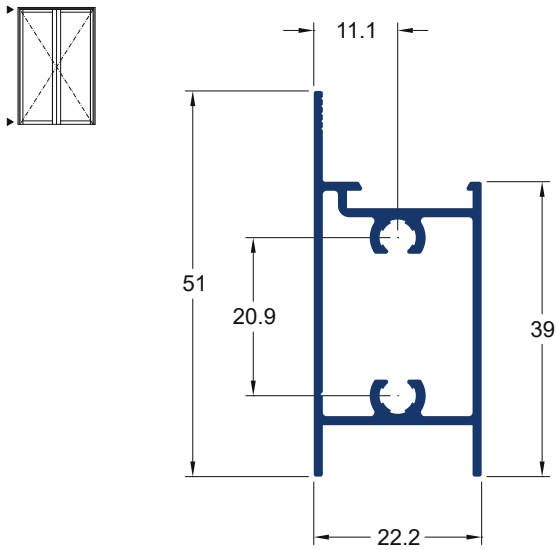

VT-111	Montante - Folha
0,640 kg/m	

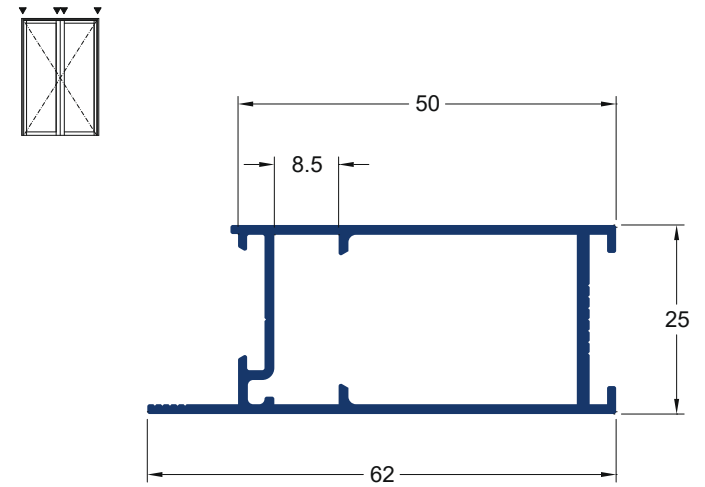

25-548	Mata - Junta
0,283 kg/m	

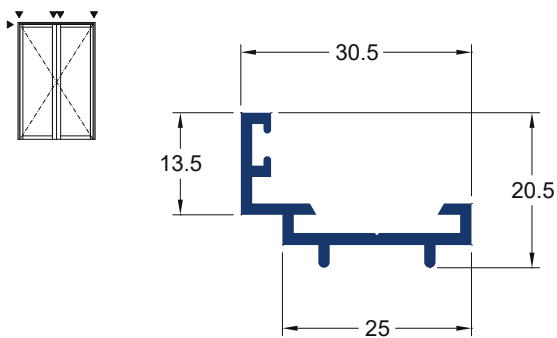

TQ-055	Tubo Quadrado
0,300 kg/m	

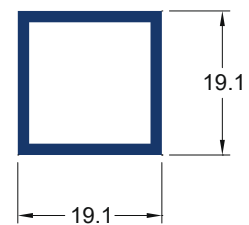

VZ-001	Veneziana
0,330 kg/m	

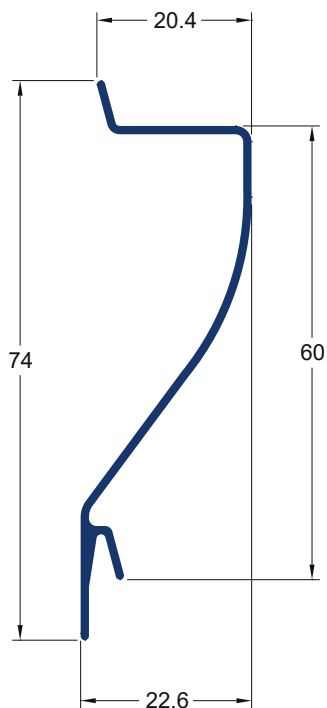

US-001	Veneziana Usinada
0,330 kg/m	

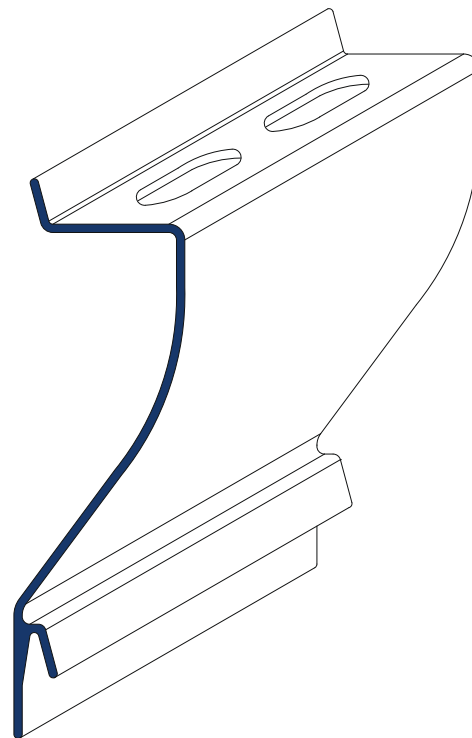

VZ-050	Veneziana
0,290 kg/m	

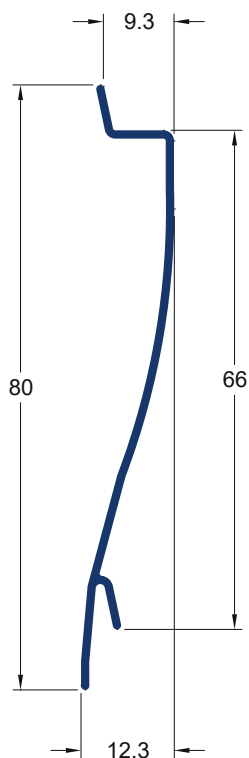

US-050	Veneziana Usinada
0,290 kg/m	

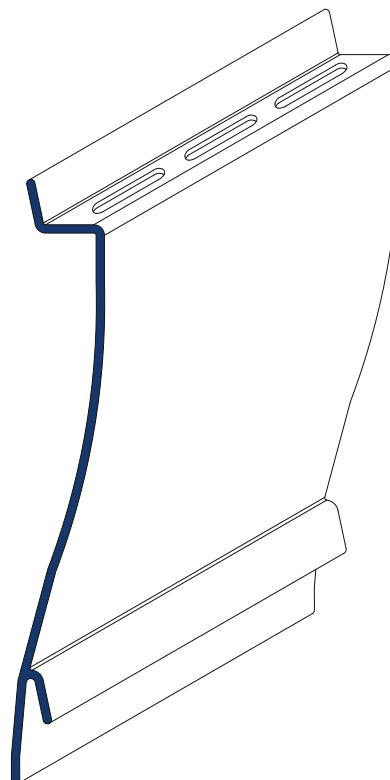

ECO-347

0,135 kg/m

Arremate

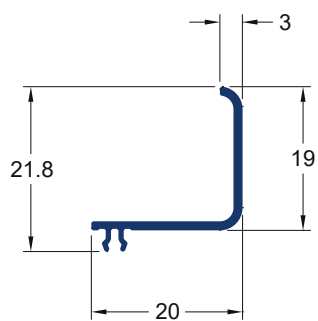

VT-379 - APLICAÇÃO COM ECO347

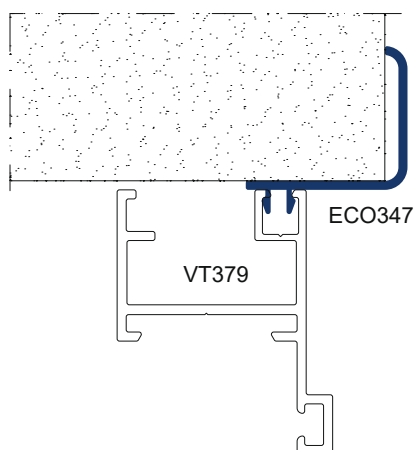

VT-479 - APLICAÇÃO COM ECO347

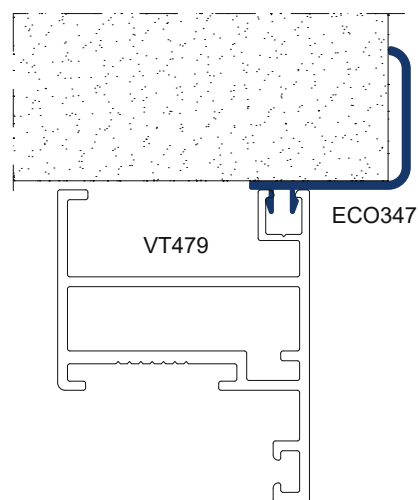

código perfil	descrição	página
BRA-702	-	9.008
BRA-703	-	9.008
BRA-704	-	9.008
BRA-705	-	9.008
BRA-725	-	9.008
CAL-948	Calço da Folha Fixa	9.001
CHU-787	Chumbador - Contra marco	9.011
CHU-838	Chumbador - Contra marco	9.011
CHU-840	Chumbador - Contra marco	9.011
CHU-864	Chumbador - Contra marco	9.011
CHU-PER01	Chumbador em aço galvanizado para contra marco	9.011
CON-280	Concha Cega - Janela	9.003
CON-295	Contra Testa - Porta de Giro	9.009
CON-370	Contrafecho - Janela e Porta de Correr	9.002
CON-376	Fixador de Travessa - Janela Maxim-ar	9.008
CON-409	Contrafecho para Fechadura Porta de Correr	9.002
CON-7611	Fecho Concha - Janela	9.005
CTF-7611	Contra Fecho para Fecho CON-7611	9.005
DOB-840	Dobradiça - Porta de Giro	9.009
FEC009	Fecho para Janela Maxim-ar	9.008
FEC010	Fecho para Janela Maxim-ar	9.008
FEC-012	Fecho Concha - Porta	9.004
FEC-052	Concha Cega - Porta	9.004
FEC-055	Contrafecho - Janela e Porta de Correr	9.002
FEC-056	Fecho direito - Janela de Correr	9.006
FEC-057	Fecho direito - Janela de Correr	9.006
FEC-058	Fecho esquerdo - Janela de Correr	9.006
FEC-060	Fecho esquerdo - Janela de Correr	9.006
FEC-1900	Fecho Unha - Porta de Giro	9.009
FEC-636	Fecho Concha Janela	9.003
FIT-200	Fita Vedadora sem Barreira Plástica	9.013
FIT-206	Fita Vedadora sem Barreira Plástica	9.013
FIT-212	Fita Vedadora sem Barreira Plástica	9.013
FIT-246	Fita Vedadora sem Barreira Plástica	9.013
FRA-822	Fechadura - Porta de Giro	9.009
GUA-006	Guarnição em EPDM	9.012
GUA-007	Guarnição em EPDM	9.012
GUA-053	Guarnição em EPDM	9.012

código perfil	descrição	página
GUA-157	Guarnição Adesiva Esponjosa	9.013
GUA-171	Guarnição Adesiva Esponjosa	9.013
GUA-172	Guarnição Adesiva Esponjosa	9.013
GUA-239	Guarnição em EPDM	9.012
GUA-256	Guarnição em EPDM	9.012
GUA-258	Guarnição Adesiva Esponjosa	9.013
GUA-259	Guarnição em EPDM	9.012
GUA-282	Guarnição Adesiva Esponjosa	9.014
GUA-283	Guarnição em EPDM	9.012
GUA-284	Guarnição em EPDM	9.012
LIN-7611	Lingueta para Fecho CON-7611	9.005
MAC-927	Maçaneta com Espelho - Porta de Giro	9.009
NYL-042	Tampa Furo	9.001
NYL-190	Presilha para Arremate	9.010
NYL-329	Caixa Dreno	9.001
NYL-332	Gula	9.001
NYL-335	Vedação Superior	9.001
NYL-355	Recobrimento - Janela Maxim-ar 90°	9.008
NYL-356	Tampa para Montante	9.007
NYL-357	Tampa para Montante	9.007
NYL-414	Batedeira	9.001
PAR-428	Parafuso Cabeça Panela Ø 4,8 x 32 mm - Inox	9.010
PAR-431	Parafuso Cabeça Panela Ø 4,8 x 50 mm - Inox	9.010
PAR-437	Parafuso Cabeça Panela Ø 3,5 x 9,5 mm - Inox	9.010
PAR-693	Parafuso Cabeça Panela Ø 4,2 x 25 mm - Inox	9.010
PAR-694	Parafuso Cabeça Panela Ø 4,2 x 32 mm - Inox	9.010
PAR-936	Parafuso Cabeça Panela Ø 4,2 x 16 mm - Inox	9.010
PRE-965	Presilha para Arremate	9.010
REB-115	Rebite de Repuxo Ø 4 x 10,2 mm (REB-540)	9.011
REB-117	Rebite de Repuxo Ø 3,2 x 10,2 mm (REB-440)	9.011
SD-2578	Roldana Dupla com Regulagem e Rolamento - Porta	9.002
SD-2581	Roldana com Regulagem e Rolamento - Porta	9.002
SD-2588	Roldana com Regulagem sem Rolamento - Janela	9.002
SIL-697	Silicone Cura Neutra para Vedação	9.014
TAM-796	Tampa para Montante	9.007

NYL-329

Caixa de Dreno

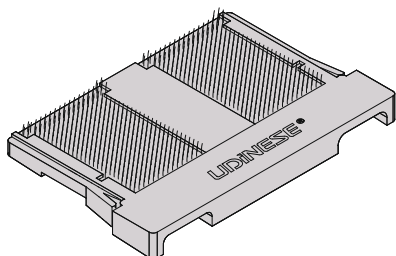

NYL-335

Vedação Superior

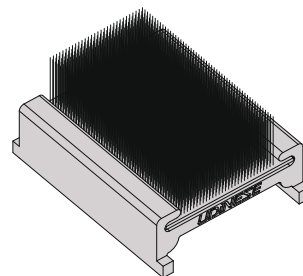

NYL-414

Batedeira

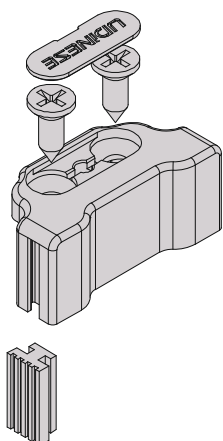

CAL-948

Calço da Folha Fixa

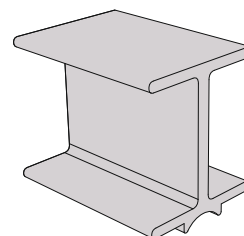

NYL-332

Guia

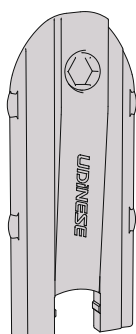

NYL-042

Tampa Furo





IMAGEM	CÓDIGO	DESCRIÇÃO	FOLHA
	SD-2588	ROLDANA COM REGULAGEM SEM ROLAMENTO - JANELA	5 KG POR ROLDANA
	SD-2581	ROLDANA COM REGULAGEM E ROLAMENTO - PORTA	20 KG POR ROLDANA
	SD-2578	ROLDANA DUPLA COM REGULAGEM E ROLAMENTO - PORTA	40 KG POR ROLDANA

CON-370

Contrafecho - Janela e porta de correr

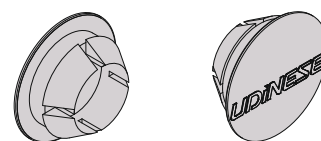
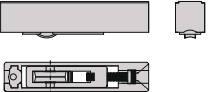

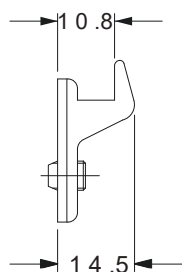
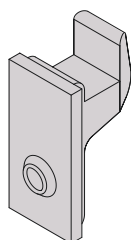
CON-409

Contrafecho para fechadura Porta de correr

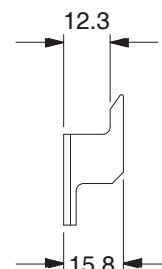
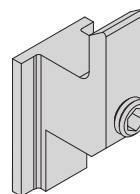

FEC-055

Contrafecho - Janela e porta de correr

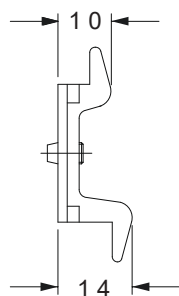
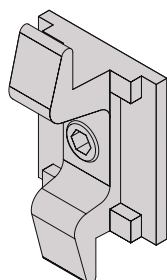

FEC-636

Fecho Concha - Janela

Detalhe de usinagem

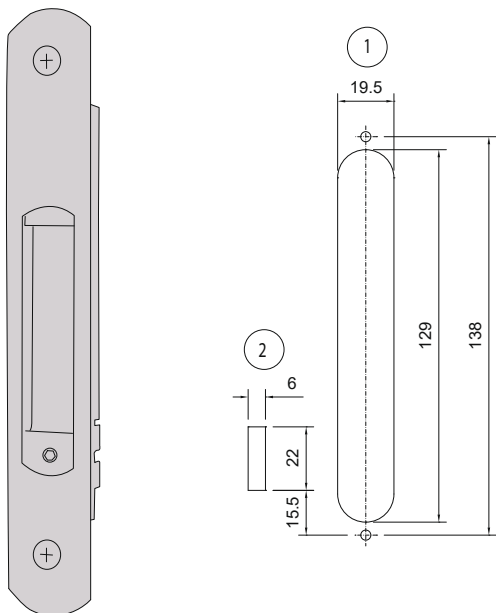

Opção reto - CON2011 (com ou sem mola)

Detalhe de usinagem

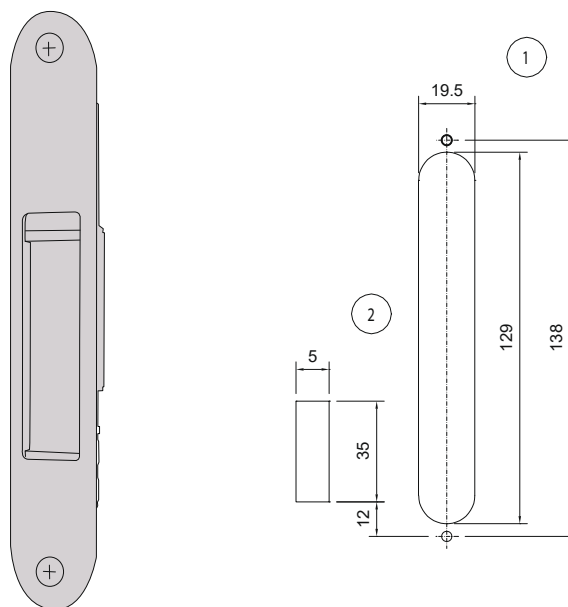

Opção arredondado - CON7411

CON-280

Concha Cega - Janela

Detalhe de usinagem

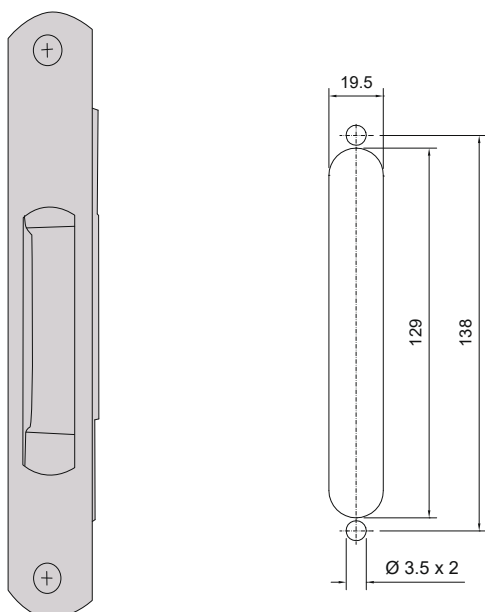

Opção reto - CON2010

Detalhe de usinagem

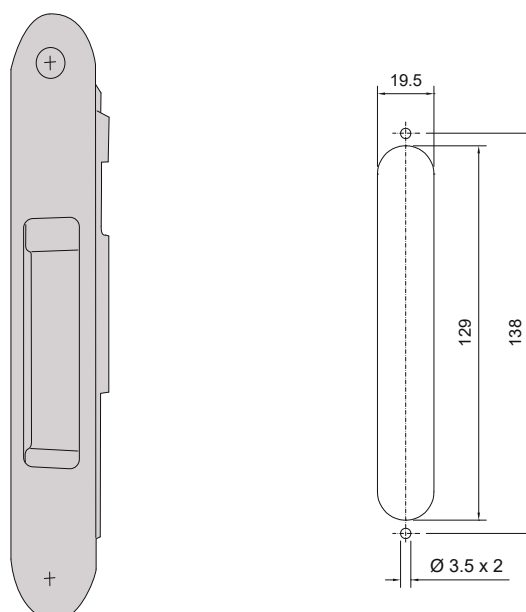

Opção arredondado - CON7311

FEC-012

Fecho Concha - Porta

Detalhe de usinagem

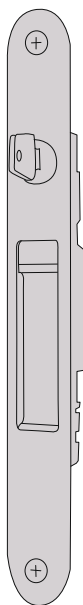

Opção c/ chave - CON7811AC

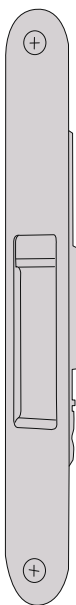

Opção s/ chave - CON7811

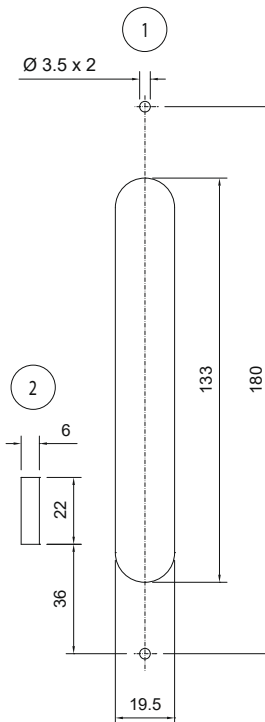

FEC-052

Concha Cega - Porta

Detalhe de usinagem

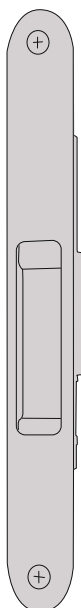

Opção arredondado - CON7711

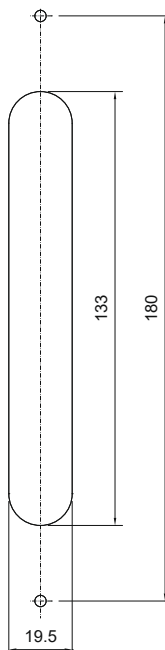

CON-7611

Fecho Concha - Janela

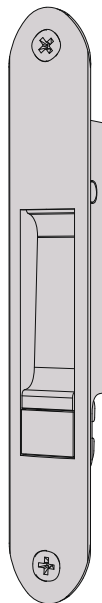

Detalhe de usinagem

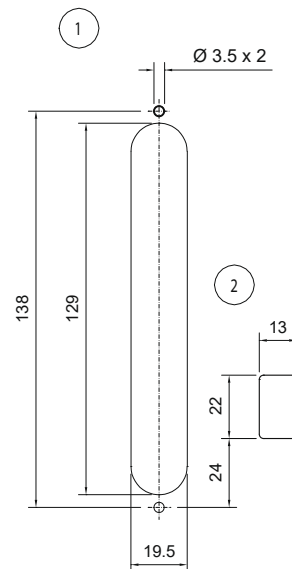

CTF-7611

Contra Fecho para Fecho CON7611

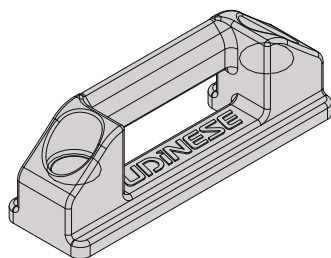

LIN-7611

Lingueta para Fecho CON7611

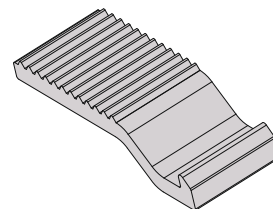

FEC-056 Fecho direito - Janela de correr

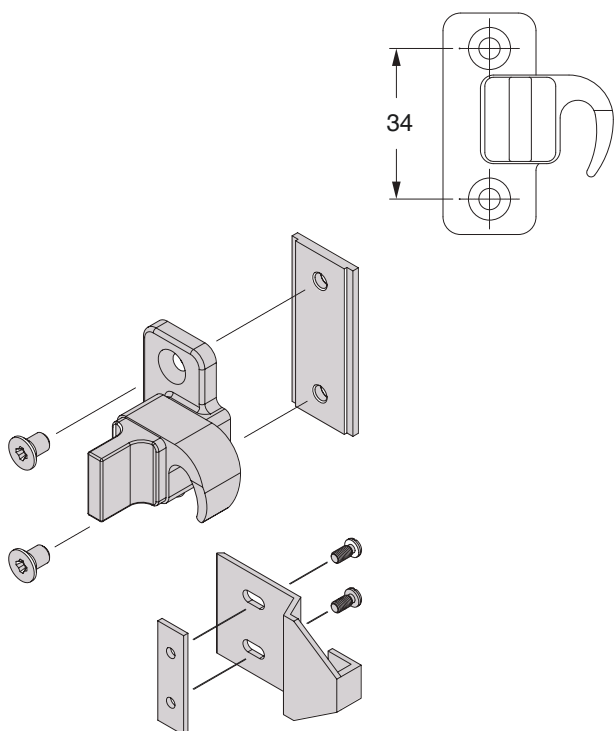

FEC-058 Fecho esquerdo - Janela de correr

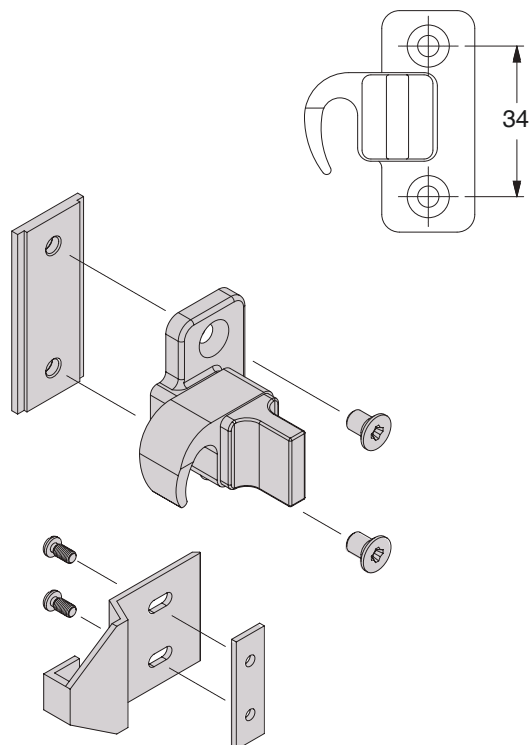

FEC-057 Fecho direito - Janela de correr

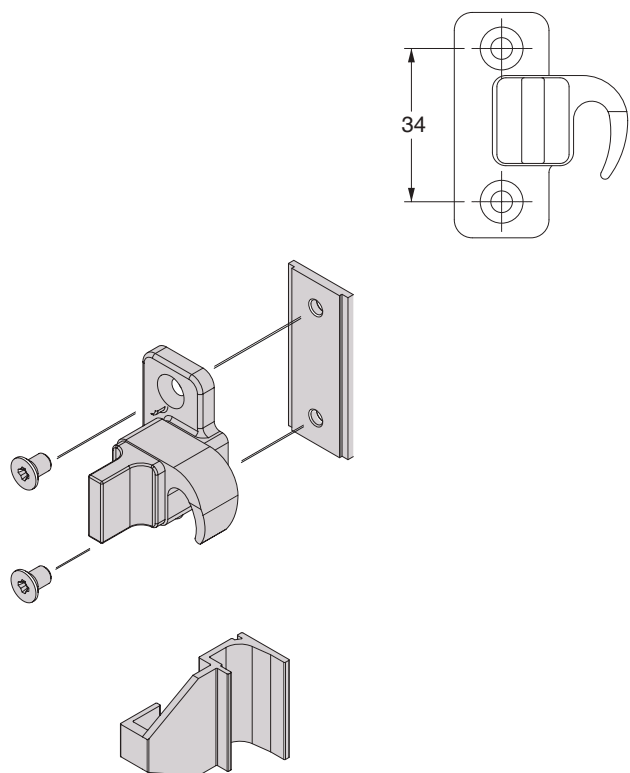

FEC-060 Fecho esquerdo - Janela de correr

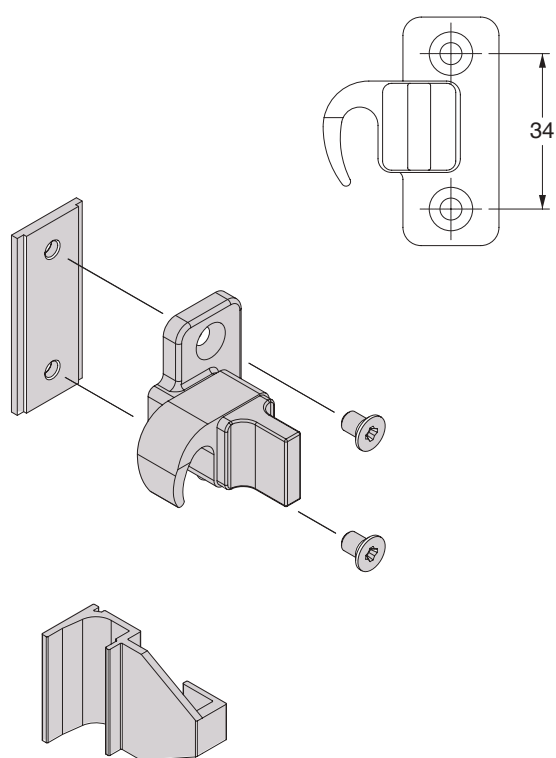

PERFIS, PROJETOS, CÓDIGOS E SISTEMAS ESTÃO SUJEITOS A ALTERAÇÃO SEM AVISO PRÉVIO.

NYL-356

Tampa para Montante

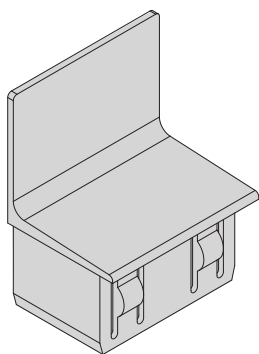
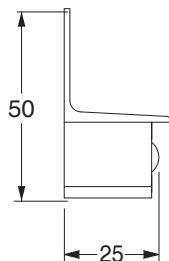

NYL-357

Tampa para Montante

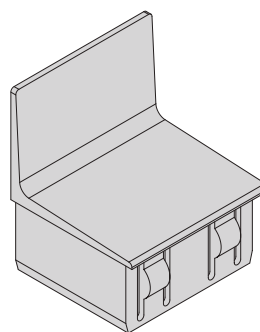
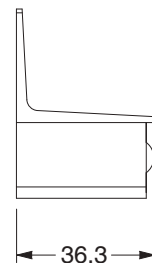

TAM-796

Tampa para Montante

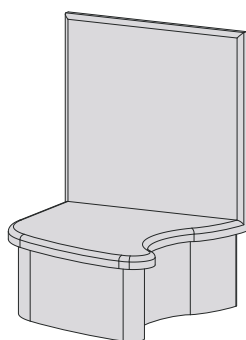
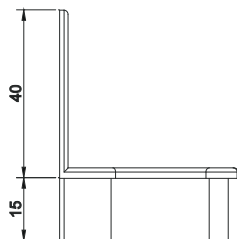

TAMPA ESQUERDA

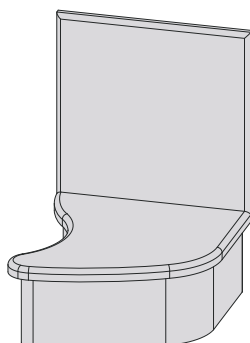

TAMPA DIREITA

CÓDIGO	DIMENSÃO	ALTURA DA FOLHA	CARGA MÁXIMA
BRA-705	250	MIN: 270 MÁX: 500	6 KG
BRA-704	400	MIN: 400 MÁX: 650	8 KG
BRA-702	500	MIN: 520 MÁX: 810	10 KG
BRA-703	750	MIN: 810 MÁX: 900	11 KG
BRA-725	810	MIN: 900 MÁX: 1200	15 KG

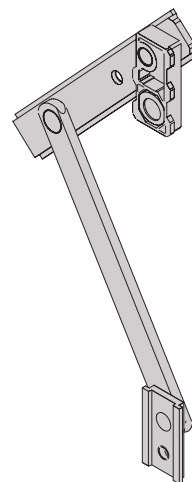

FEC009

Fecho para Janela Maxim-ar

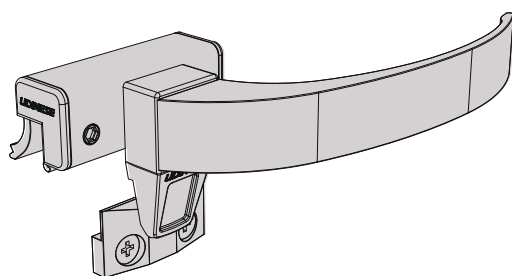

FEC010

Fecho para Janela Maxim-ar

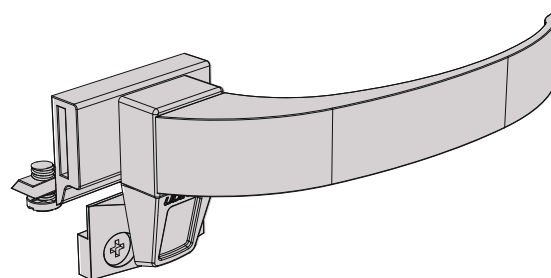

NYL-355

Recobrimento - Janela Maxim-ar 90°

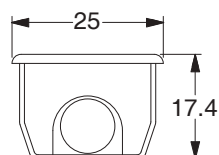
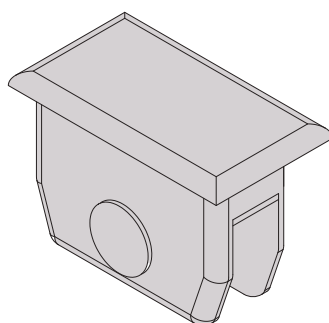

CON-376

Fixador de Travessa - Janela Maxim-ar

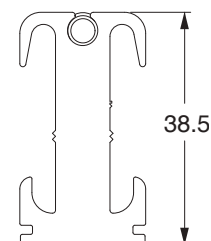
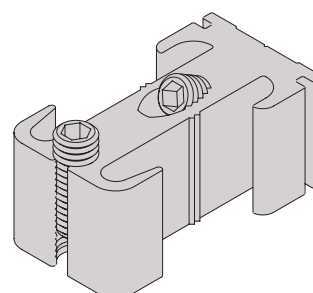

FRA-822

Fechadura - Porta de Giro

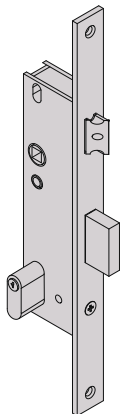

MAC-927

Maçaneta com Espelho - Porta de Giro

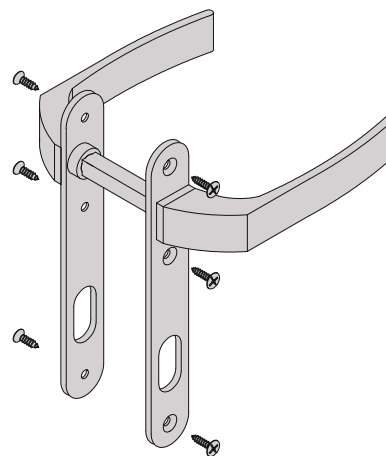

CON-295

Contra Testa - Porta de Giro

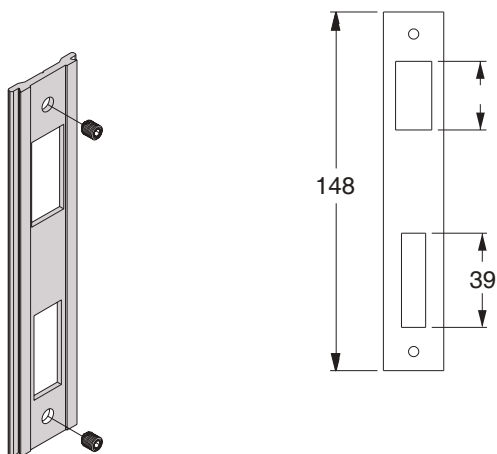

DOB-840

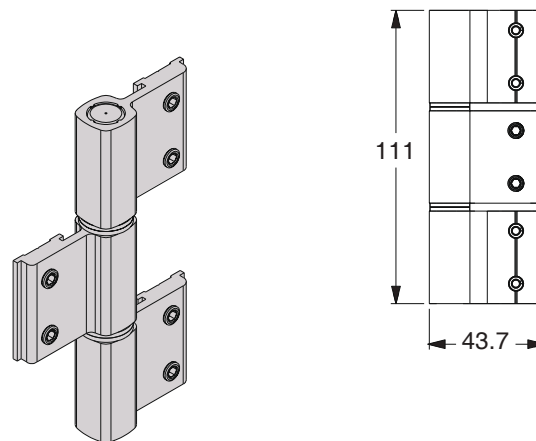

Dobradiça - Porta de Giro

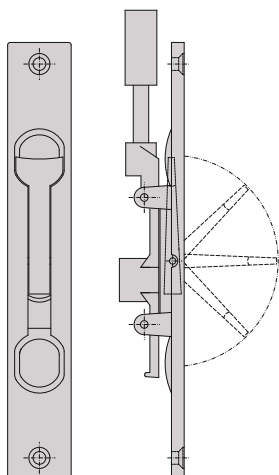

FEC-1900

Fecho Unha - Porta de Giro

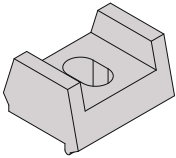
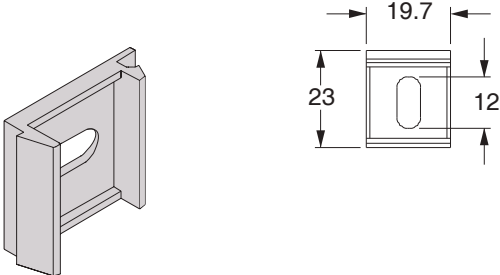

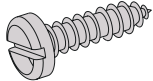
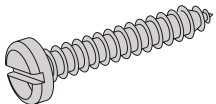
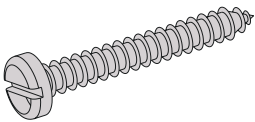
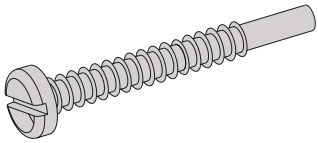
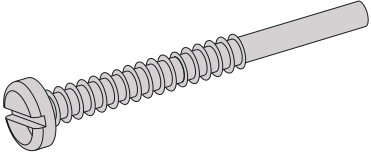
<p>NYL-190</p>	<p>Presilha para Arremate</p>	<p>PRE-965</p>	<p>Presilha para Arremate</p>
			
<p>PAR-437</p>	<p>Parafuso Cabeça Panela Ø3,5 x 9,5 mm - Inox</p>	<p>PAR-936</p>	<p>Parafuso Cabeça Panela Ø 4,2 x 16 mm - Inox</p>
 <p>Imagem ilustrativa - Será fornecido cabeça philips ou fenda.</p>		 <p>Imagem ilustrativa - Será fornecido cabeça philips ou fenda.</p>	
<p>PAR-693</p>	<p>Parafuso Cabeça Panela Ø 4,2 x 25 mm - Inox</p>	<p>PAR-694</p>	<p>Parafuso Cabeça Panela Ø4,2 x 32 mm - Inox</p>
 <p>Imagem ilustrativa - Será fornecido cabeça philips ou fenda.</p>		 <p>Imagem ilustrativa - Será fornecido cabeça philips ou fenda.</p>	
<p>PAR-428</p>	<p>Parafuso Cabeça Panela Ø4,8 x 32 mm - Inox</p>	<p>PAR-431</p>	<p>Parafuso Cabeça Panela Ø4,8 x 50 mm - Inox</p>
 <p>Imagem ilustrativa - Será fornecido cabeça philips ou fenda.</p>		 <p>Imagem ilustrativa - Será fornecido cabeça philips ou fenda.</p>	

REB-115

Rebite de Repuxo
 Ø4 x 10,2 mm (REB-540)

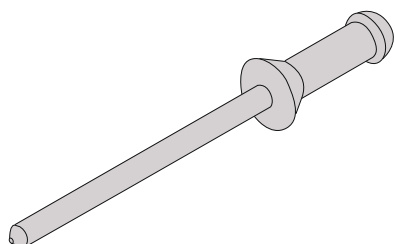

REB-117

Rebite de Repuxo
 Ø3,2 x 10,2 mm (REB-440)

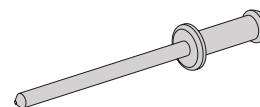

CHU-838

Chumbador - Contra marco

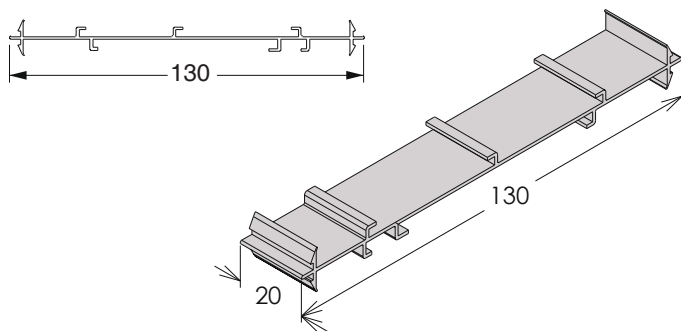

CHU-840

Chumbador - Contra marco

Perfil base CM-099

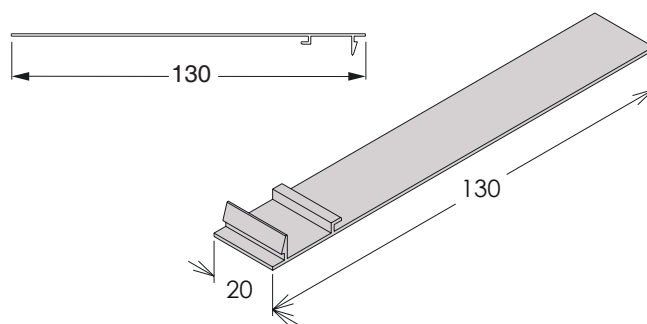

CHU-864

Chumbador - Contra marco

Perfil base CM-124

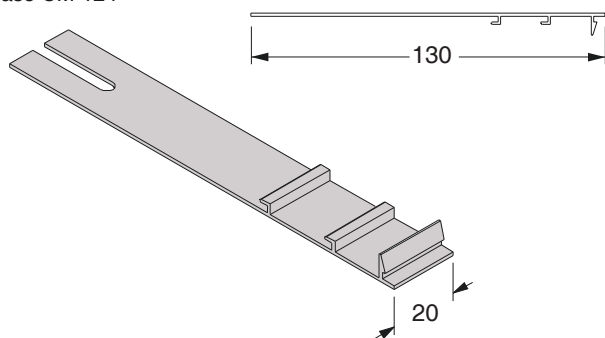

CHU-787

Chumbador - Contra marco

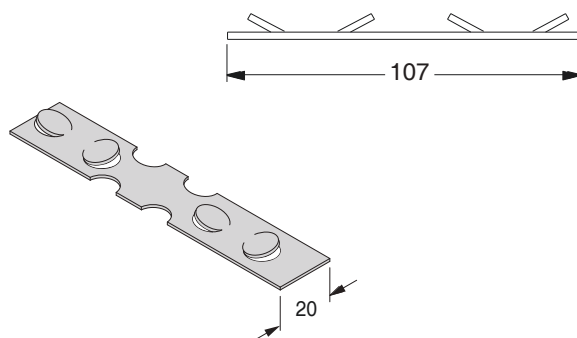

CHU-PER01

Chumbador em aço galvanizado para
 contra-marco



GUA-053

Guarnição em EPDM

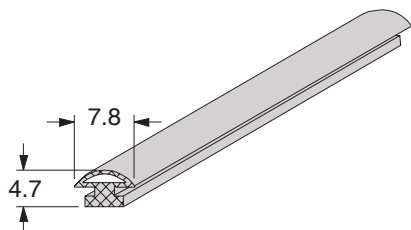

GUA-007

Guarnição em EPDM

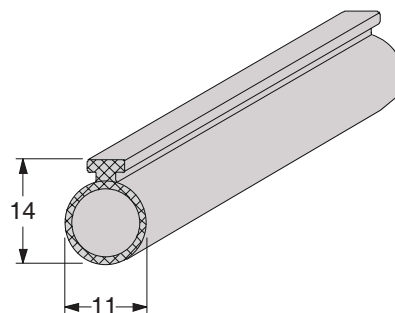

GUA-239

Guarnição em EPDM

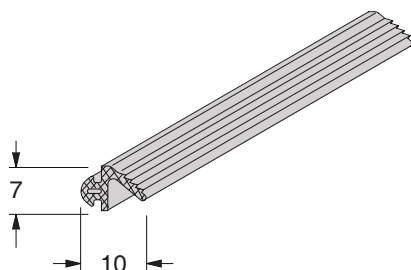

GUA-256

Guarnição em EPDM

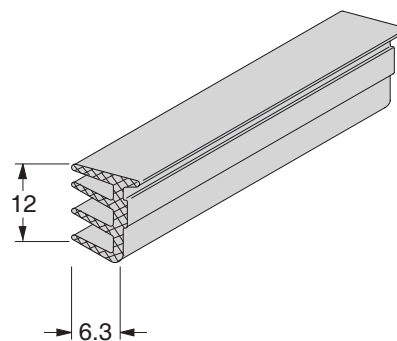

GUA-259

Guarnição em EPDM

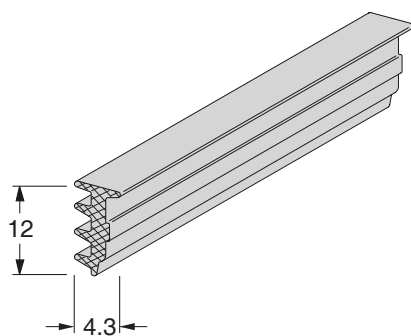

GUA-284

Guarnição em EPDM

Para vidro de 4 mm

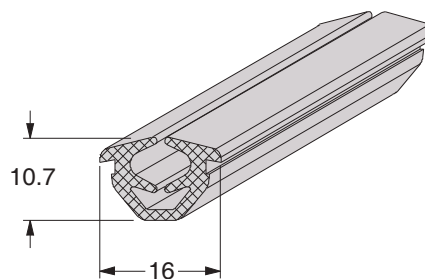

GUA-283

Guarnição em EPDM

Para vidros de 5 e 6 mm

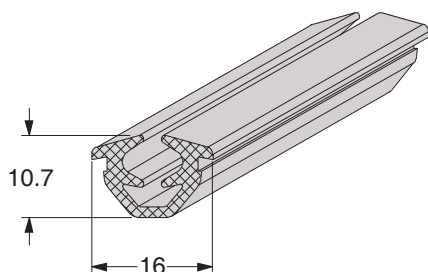

GUA-006

Guarnição em EPDM

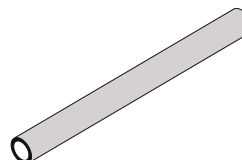

FIT-212

Fita vedadora sem barreira plástica

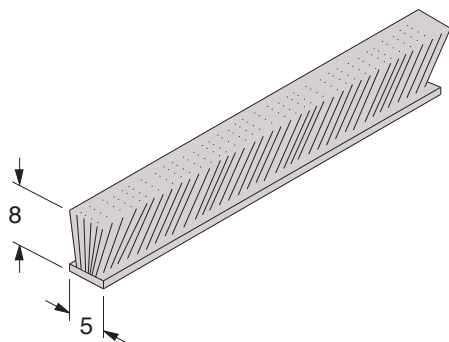

FIT-246

Fita vedadora sem barreira plástica

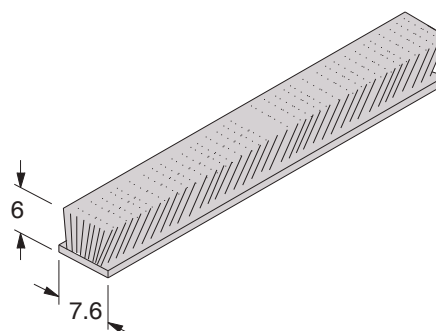

FIT-206

Fita vedadora sem barreira plástica

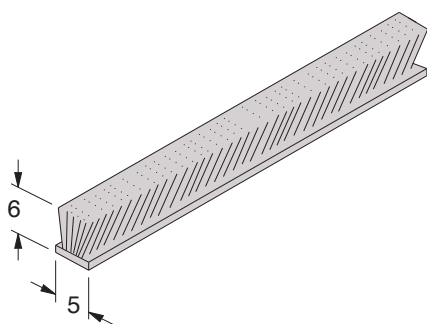

FIT-200

Fita vedadora sem barreira plástica

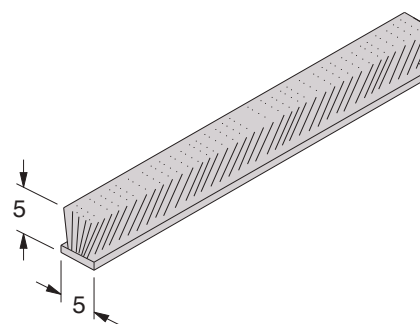

GUA-172

Guarnição adesiva esponjosa

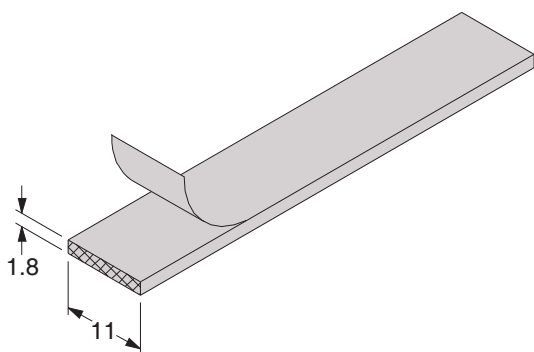

GUA-171

Guarnição adesiva esponjosa

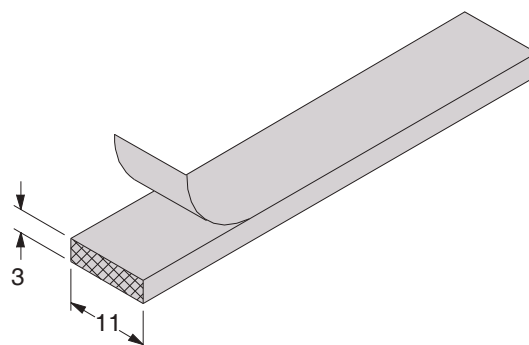

GUA-258

Guarnição adesiva esponjosa

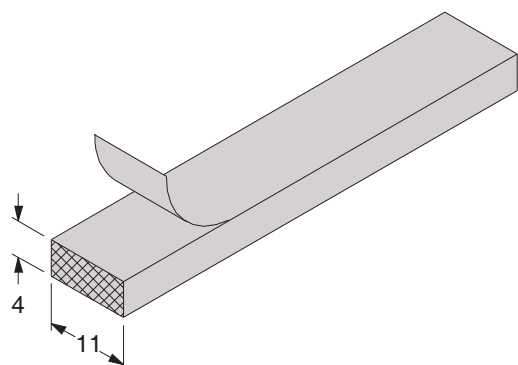

GUA-157

Guarnição adesiva esponjosa

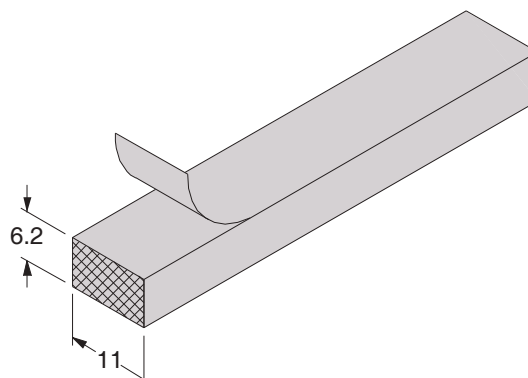

GUA-282

Guarnição adesiva esponjosa

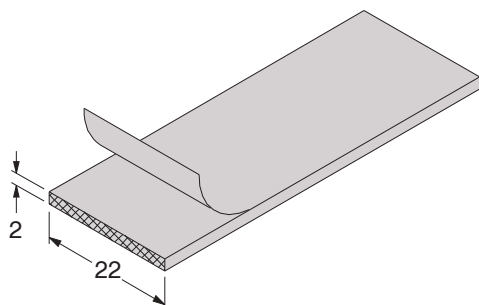

SIL-697

Silicone cura neutra para vedação



ELEVAÇÃO



CORTE 01



CORTE 02

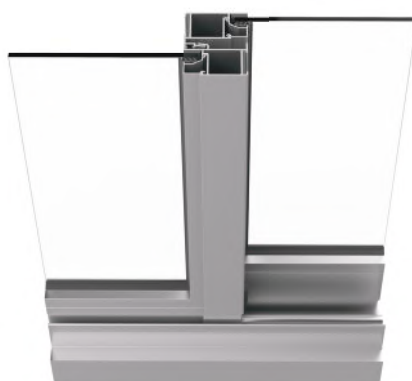

ELEVAÇÃO

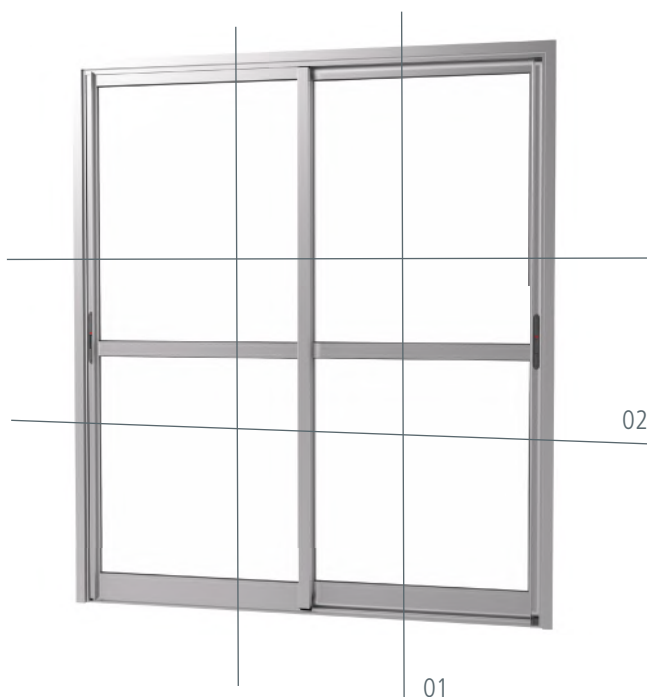

CORTE 01

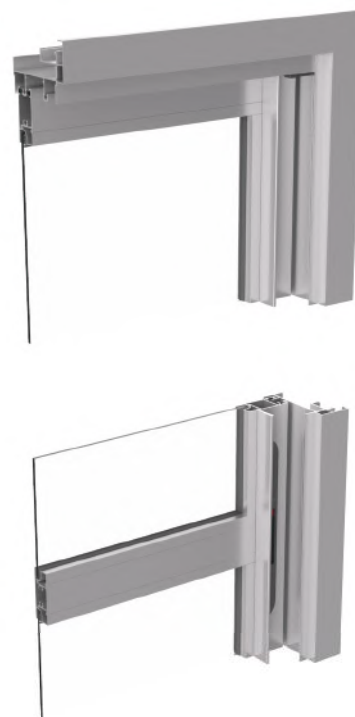

CORTE 02



VT847 + VT849



VT861 + VT861

ELEVAÇÃO

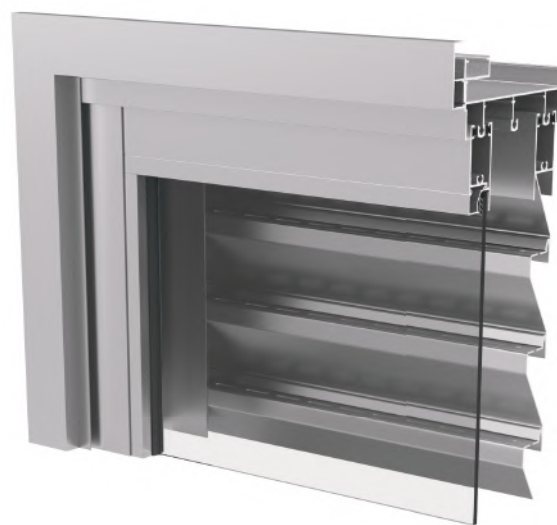

CORTE 01

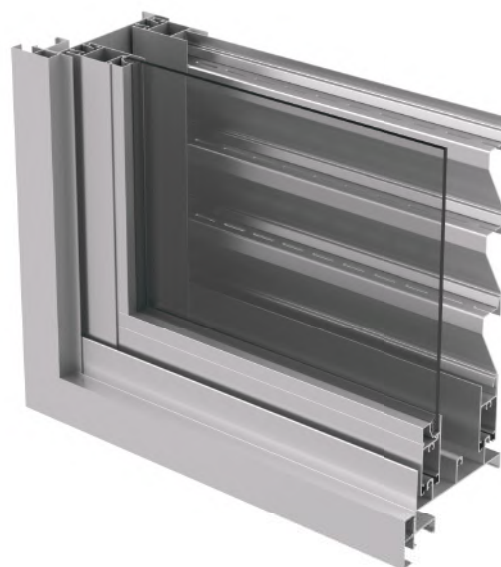

CORTE 02



ELEVAÇÃO

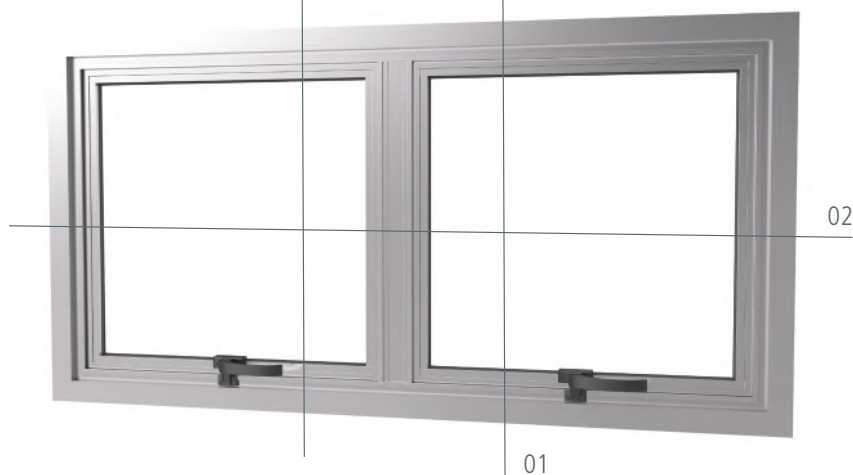

CORTE 01



CORTE 02

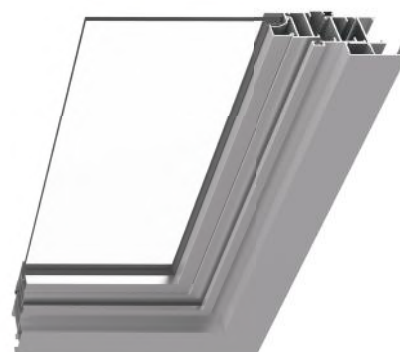

ELEVAÇÃO

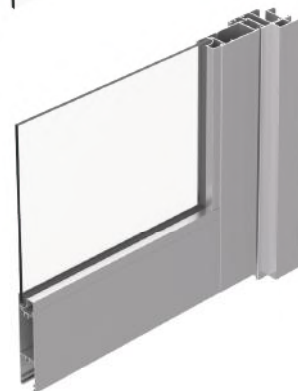

CORTE 01

CORTE 02

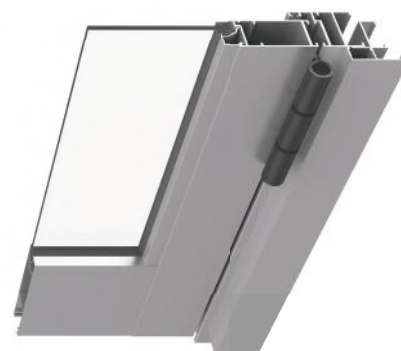

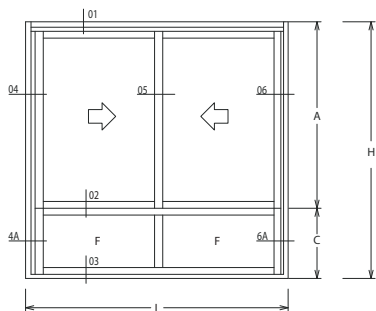

Sienc
 Vista Externa

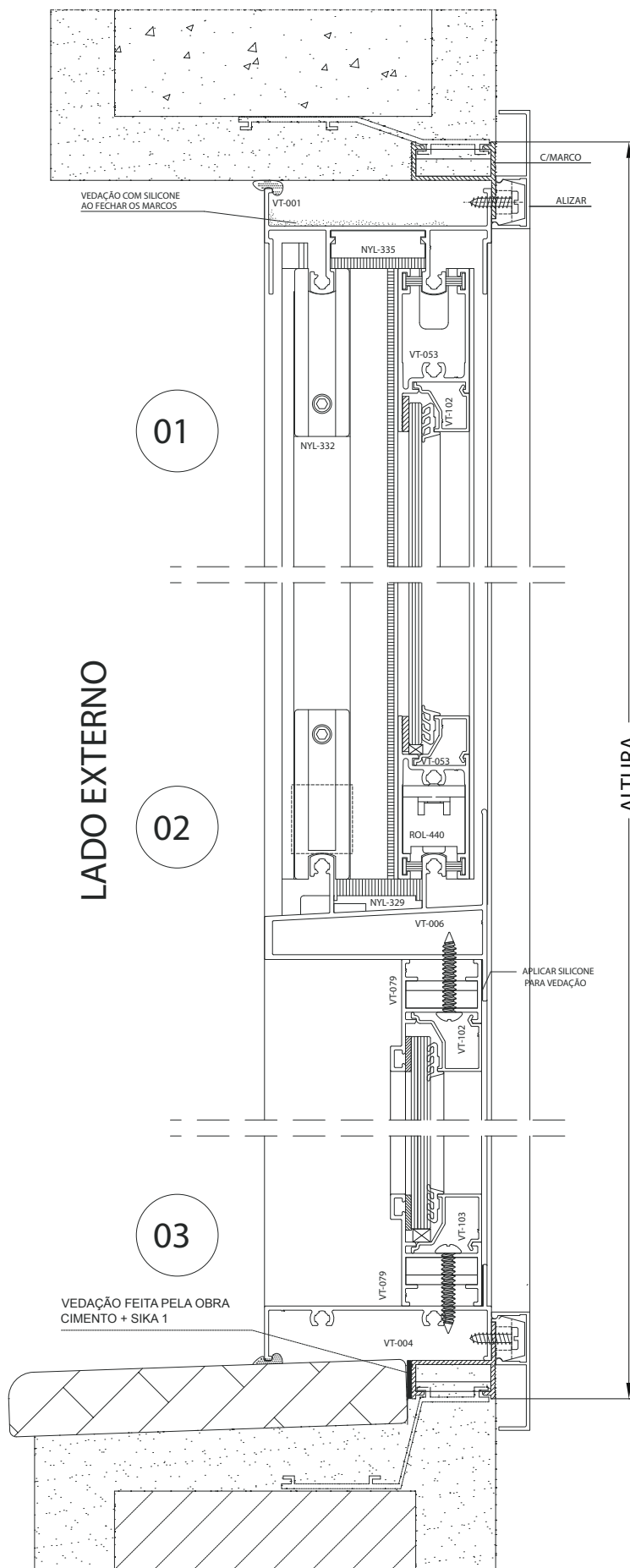

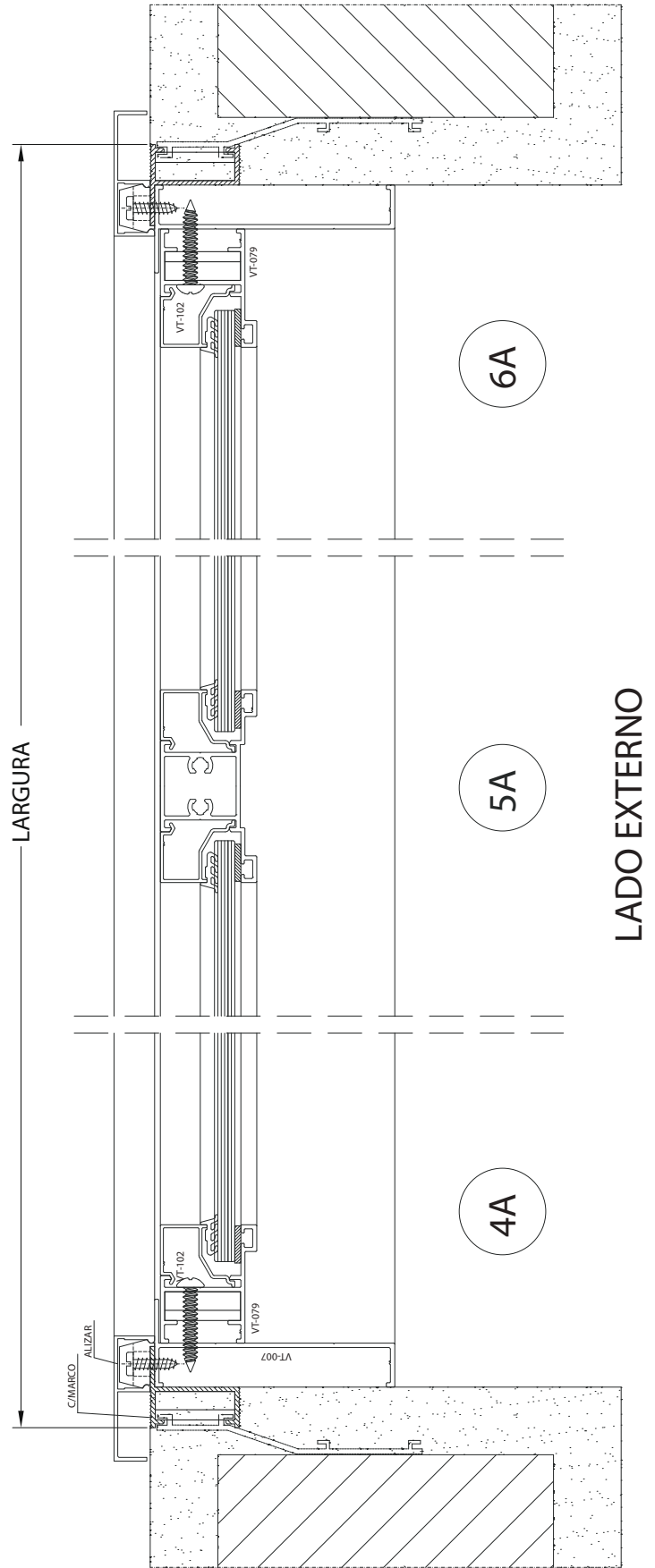
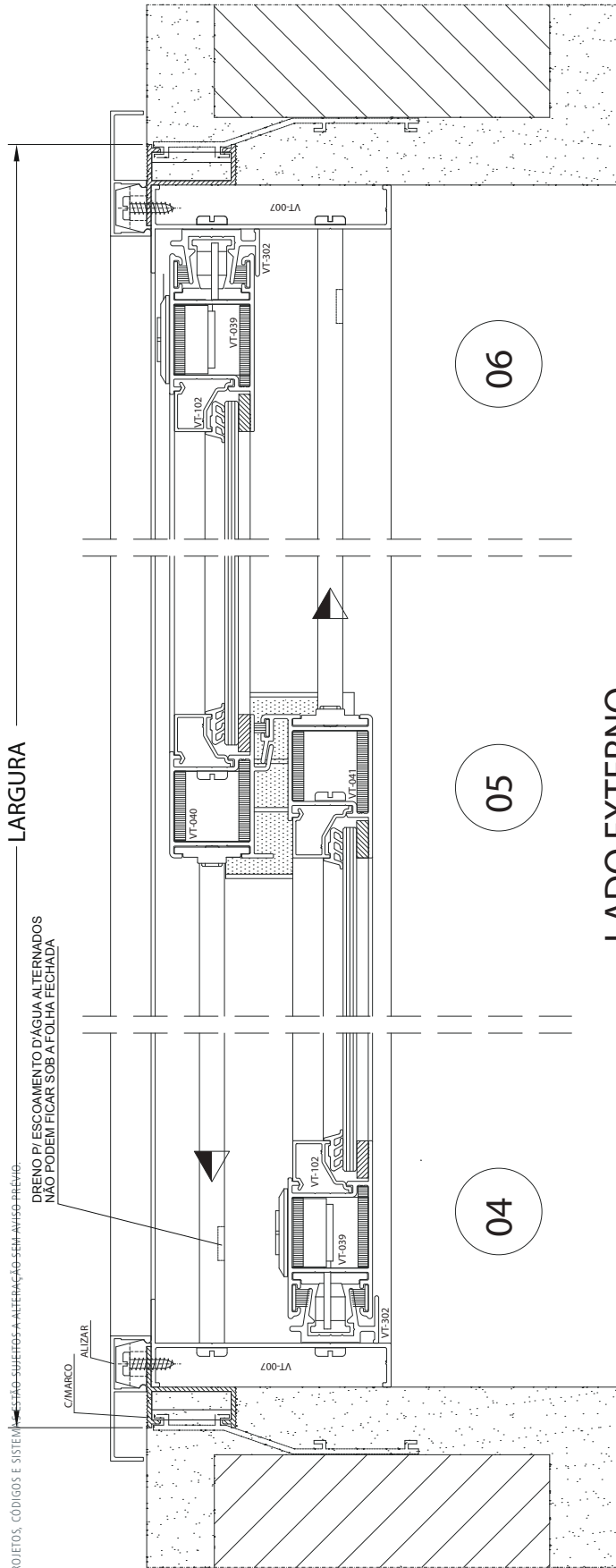

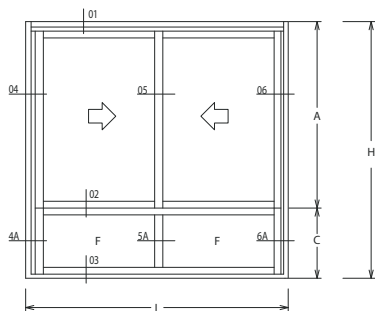

Siesc
 Vista Externa

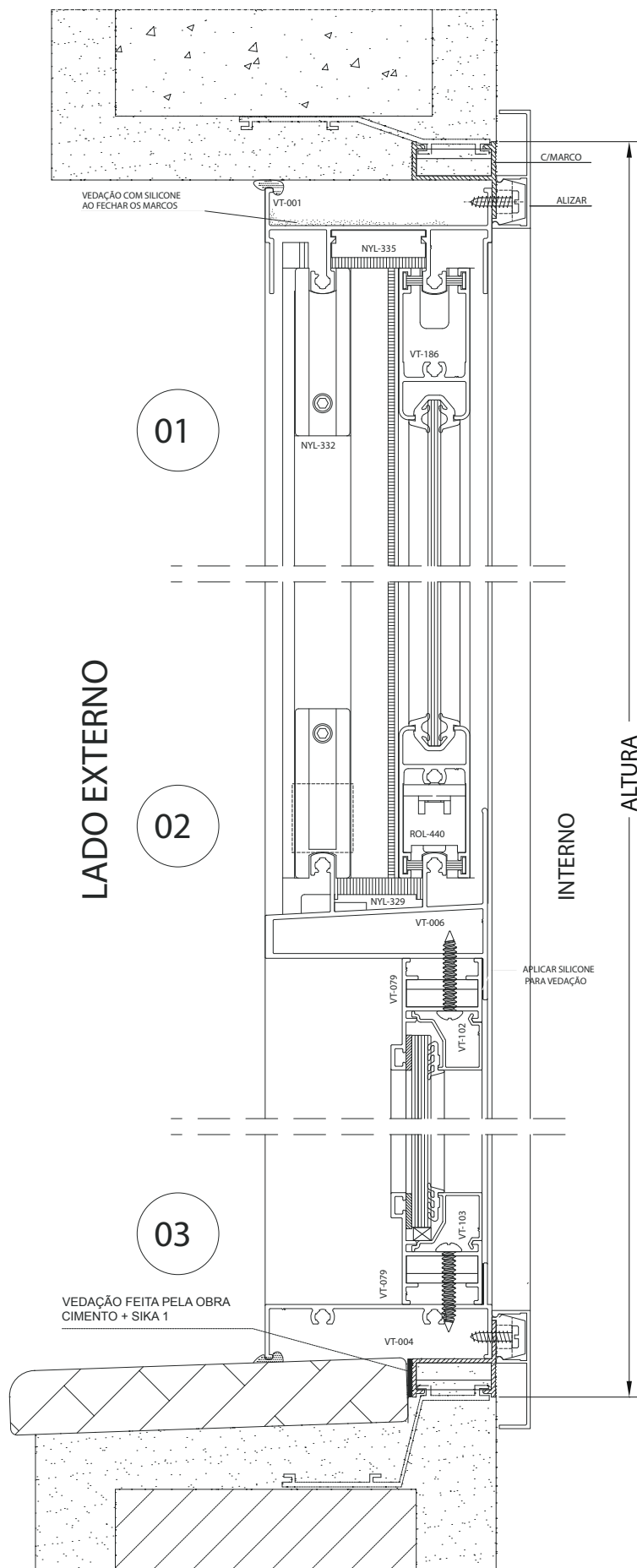

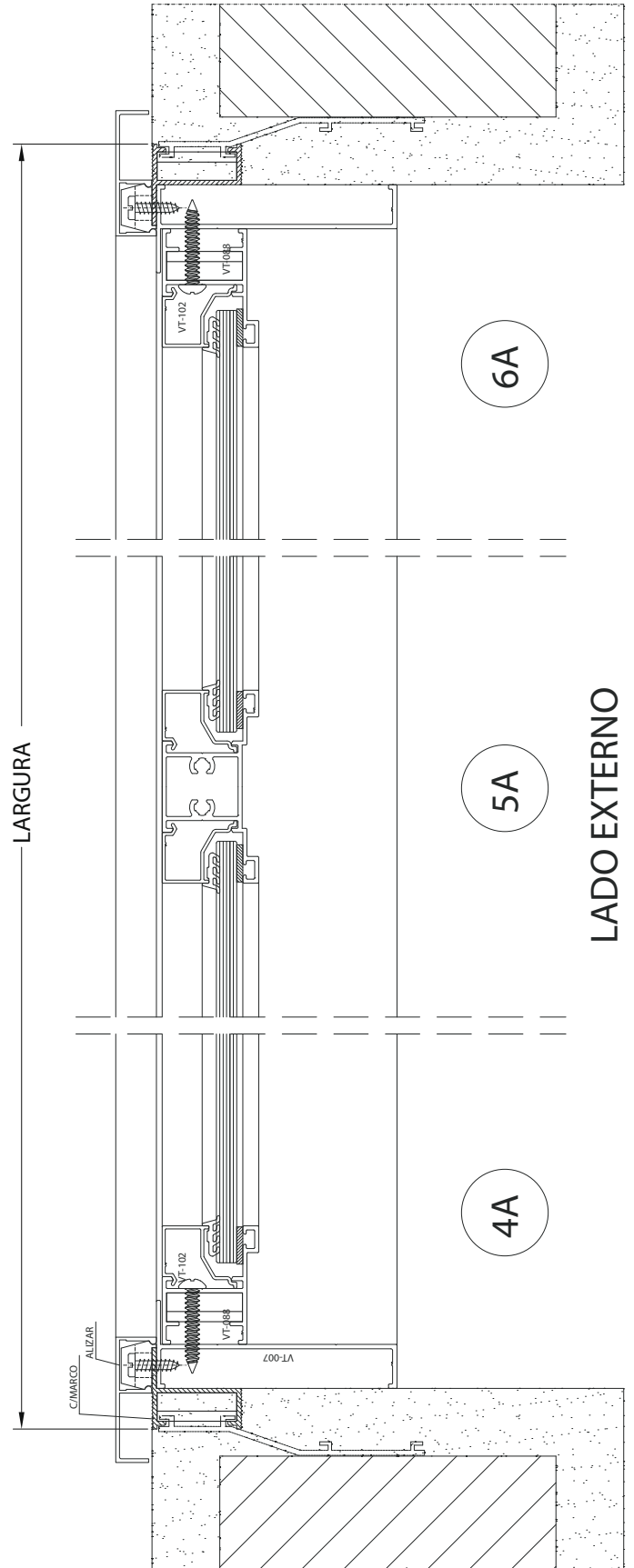
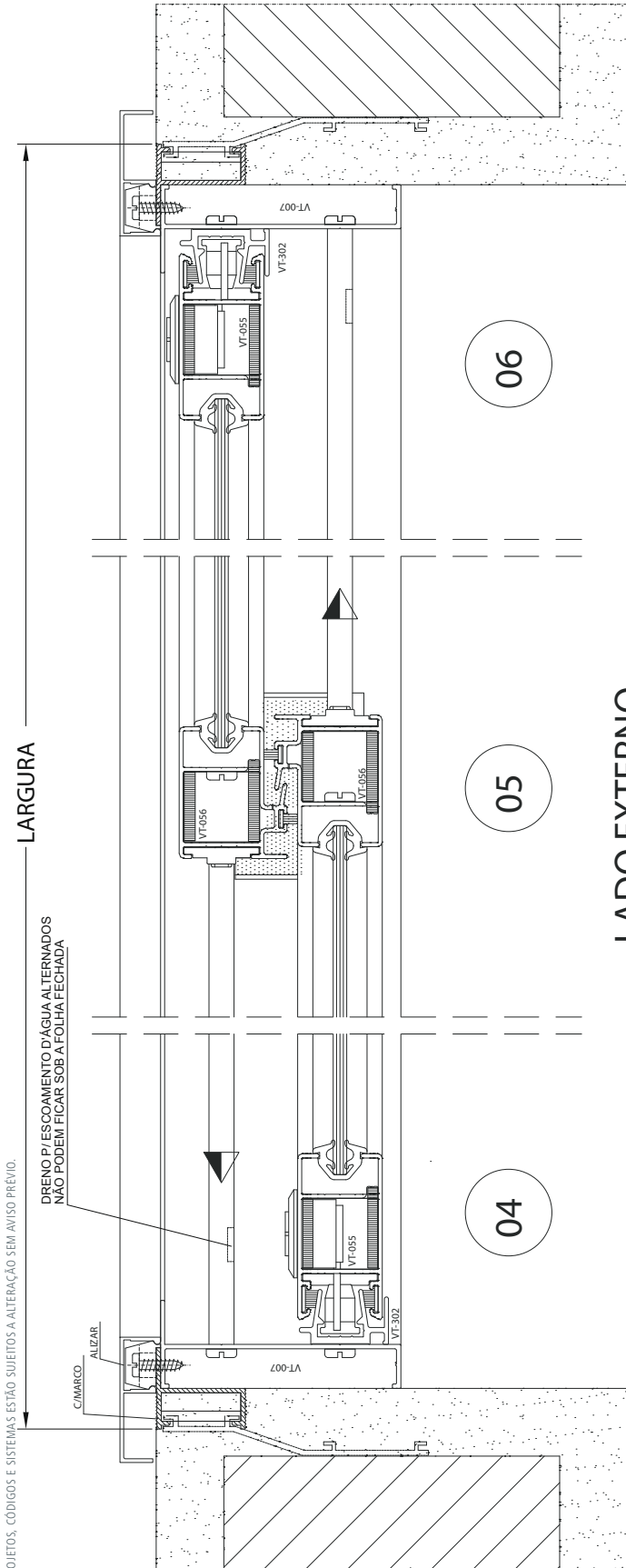

PERFIS, PROJETOS, CÓDIGOS E SISTEMAS ESTÃO SUJEITOS A ALTERAÇÃO SEM AVISO PRÉVIO.

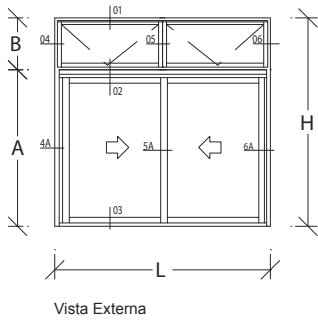

LADO EXTERNO

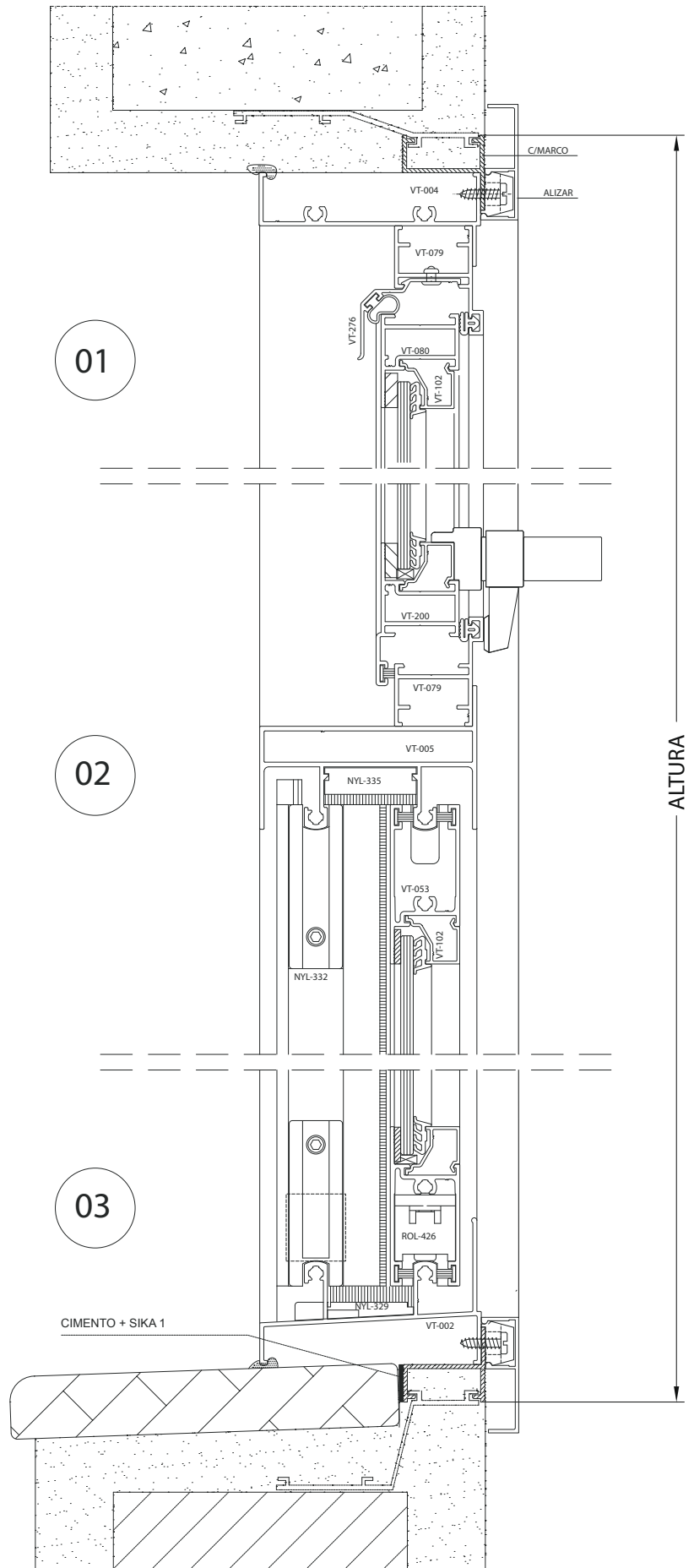

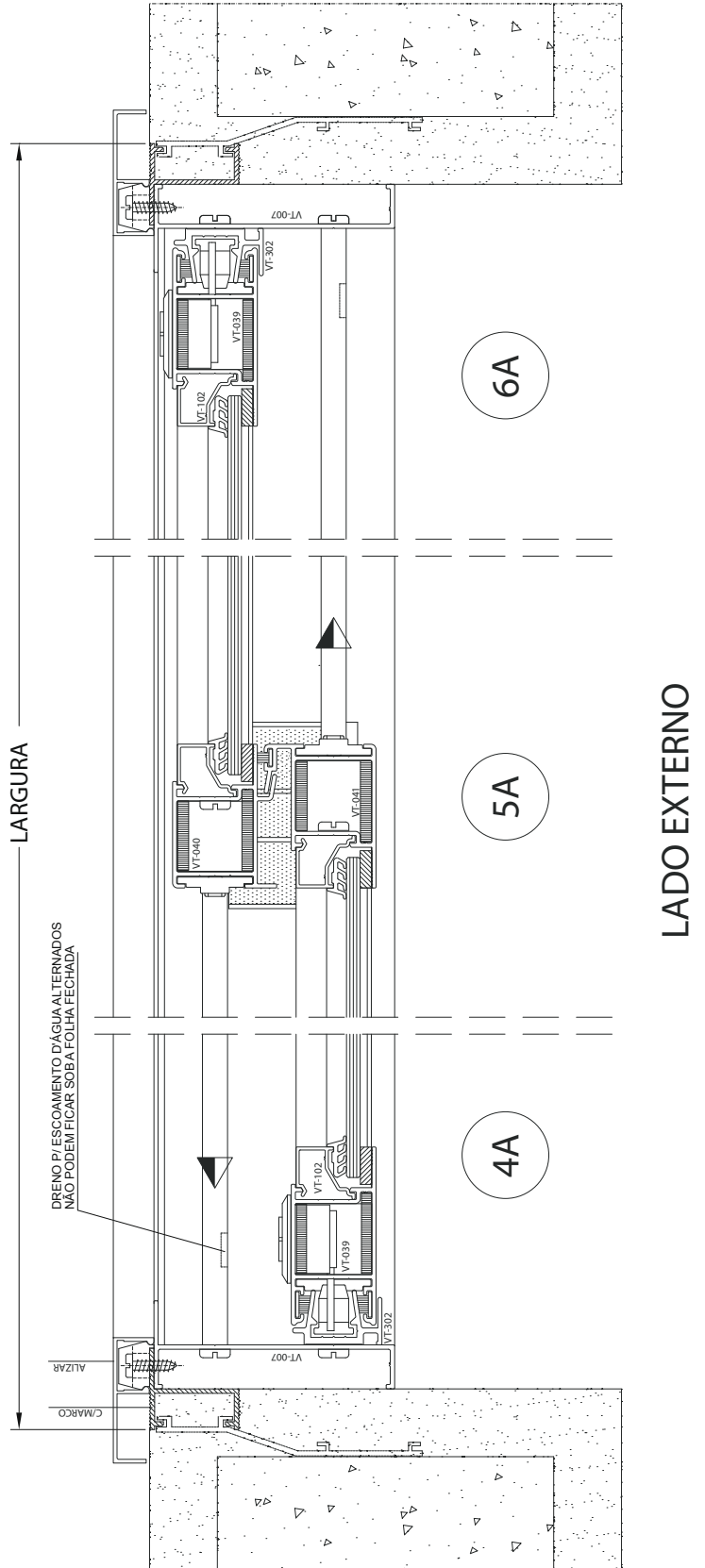
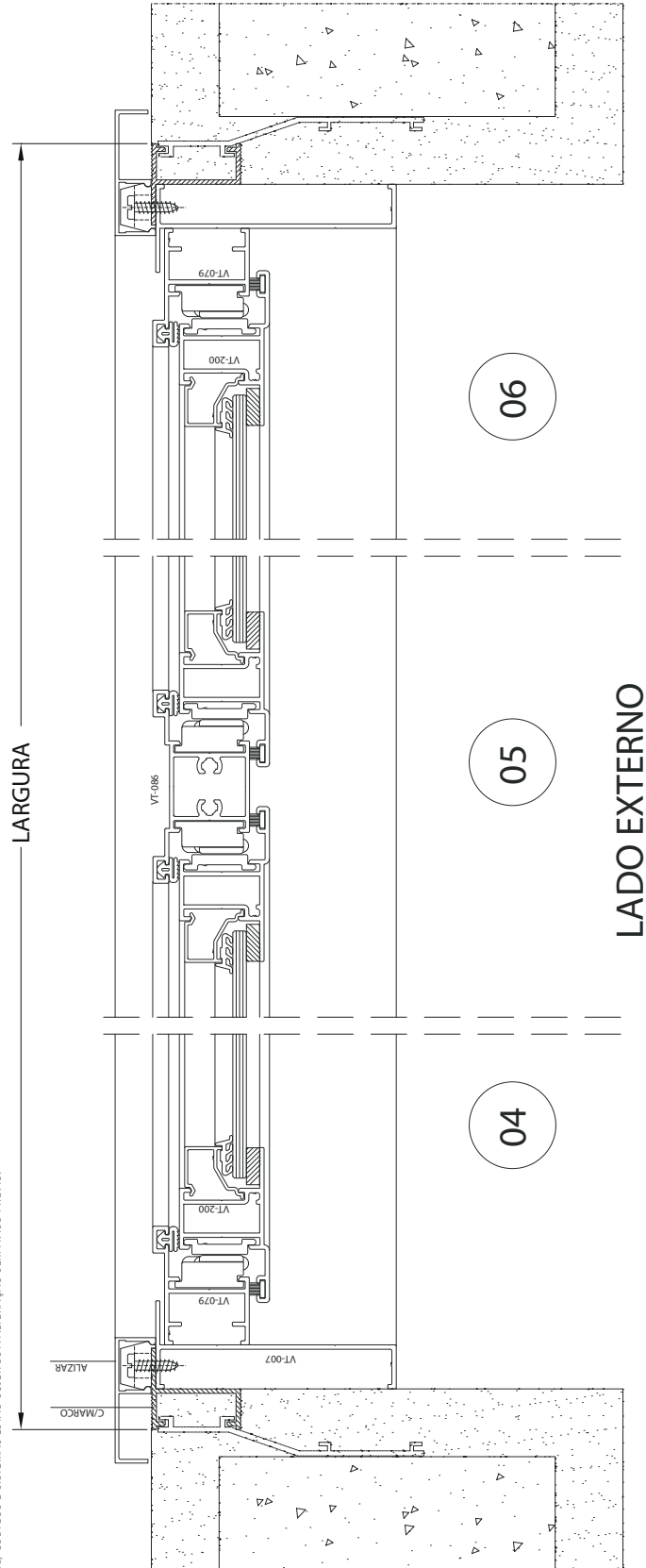

PERFIS, PROJETOS, CÓDIGOS E SISTEMAS ESTÃO SUJEITOS A ALTERAÇÃO SEM AVISO PRÉVIO.

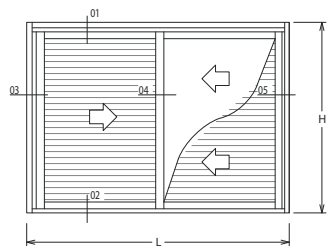

LADO EXTERNO

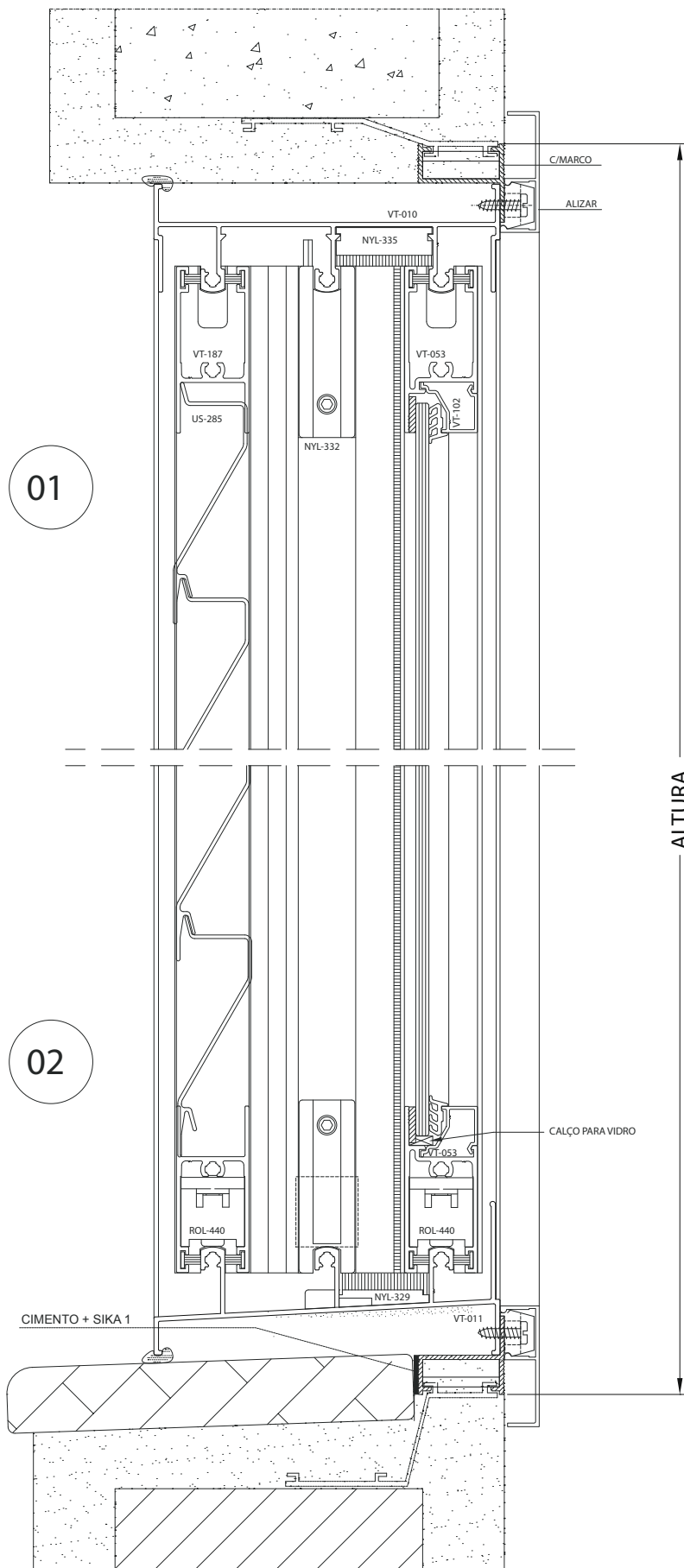

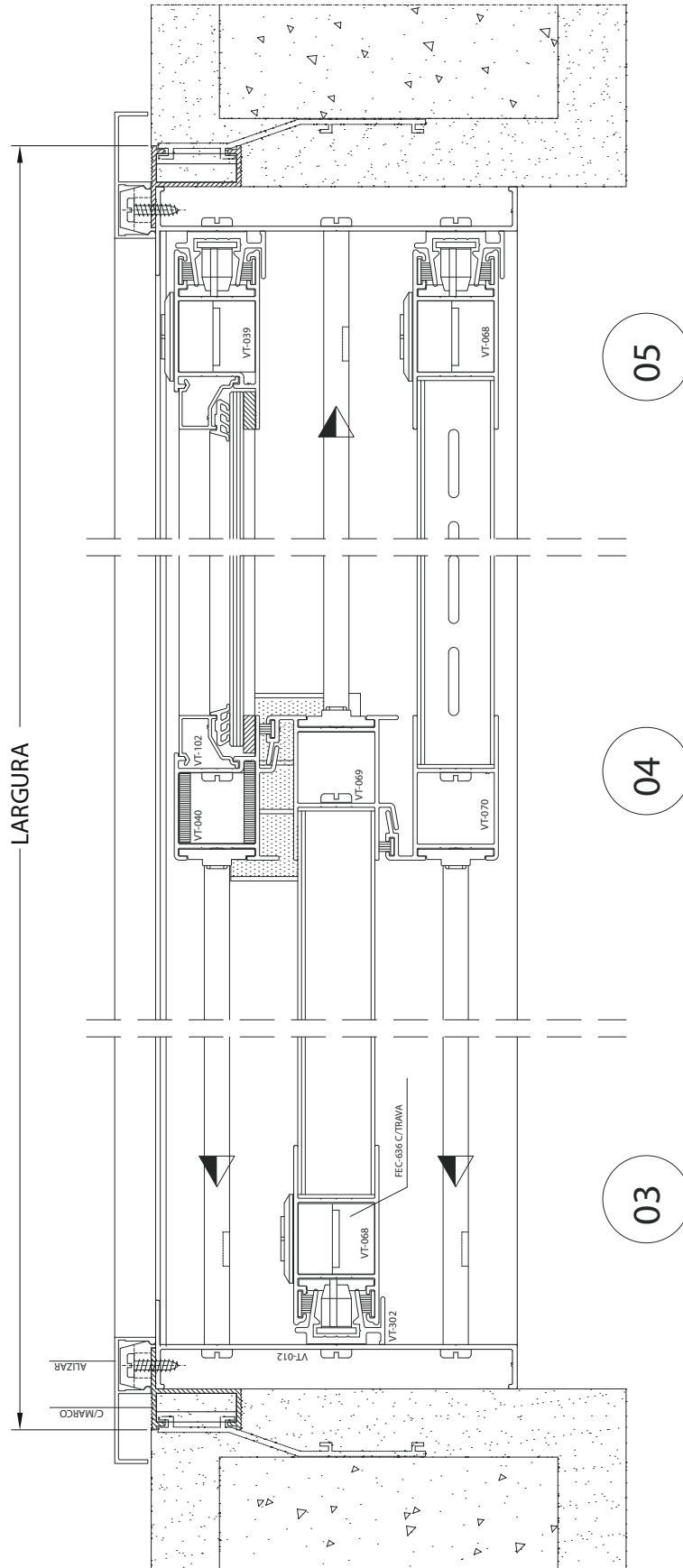

LADO EXTERNO

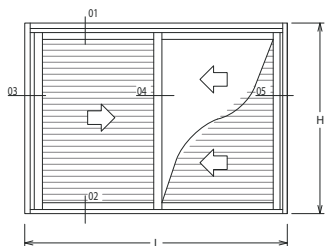

LADO EXTERNO

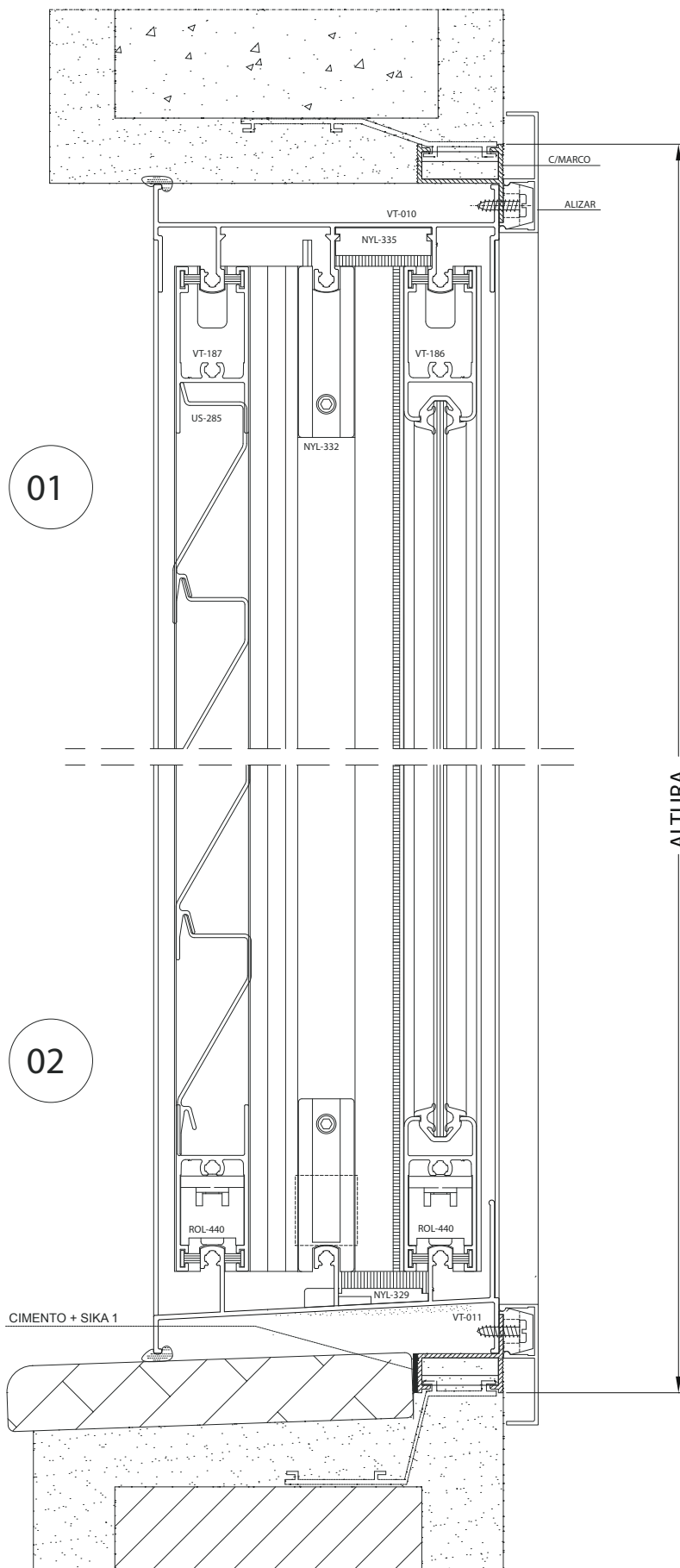

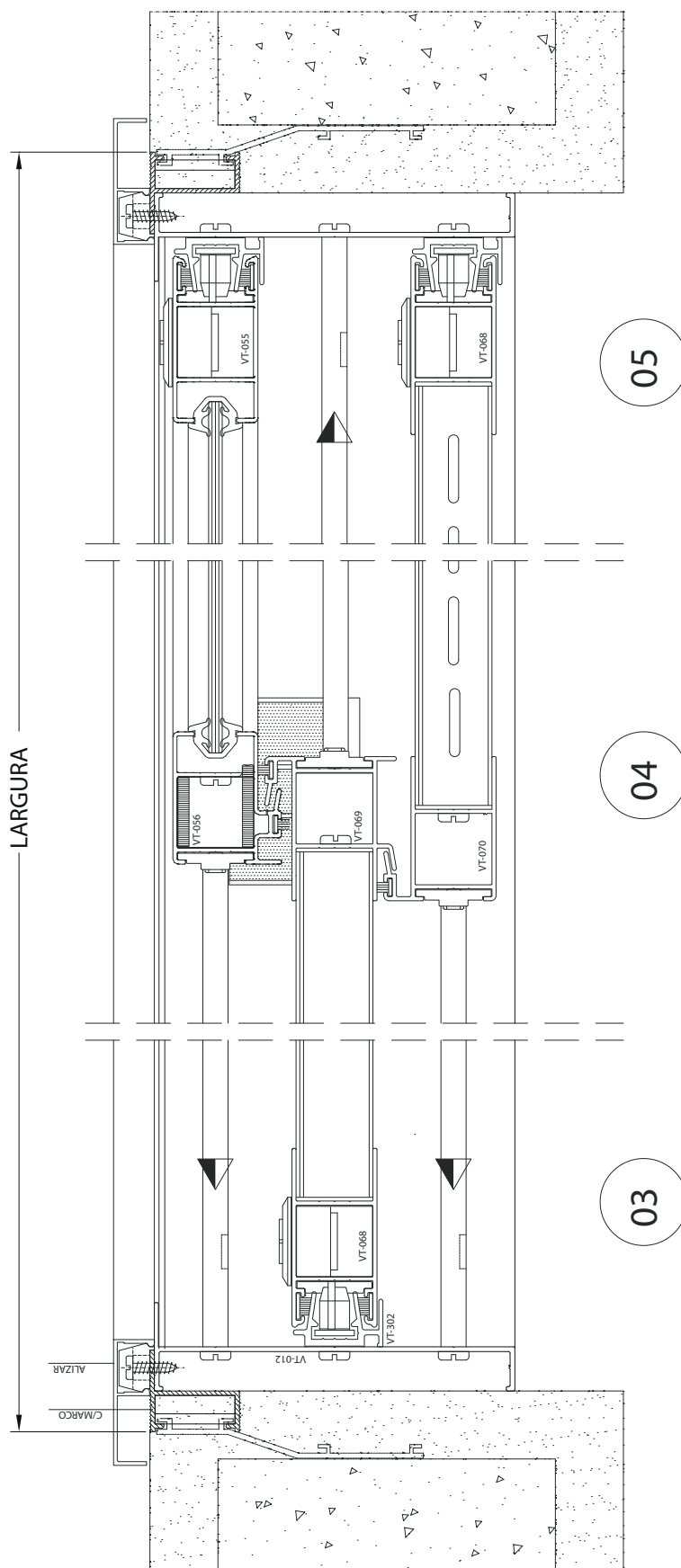

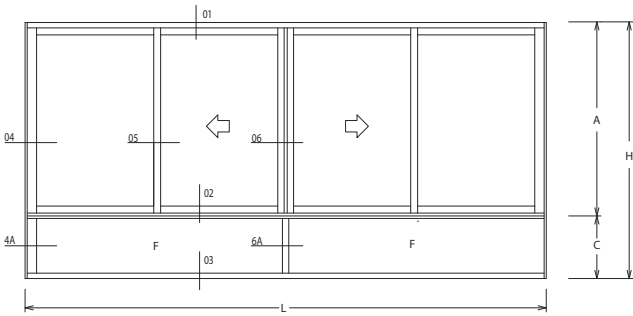

LADO EXTERNO

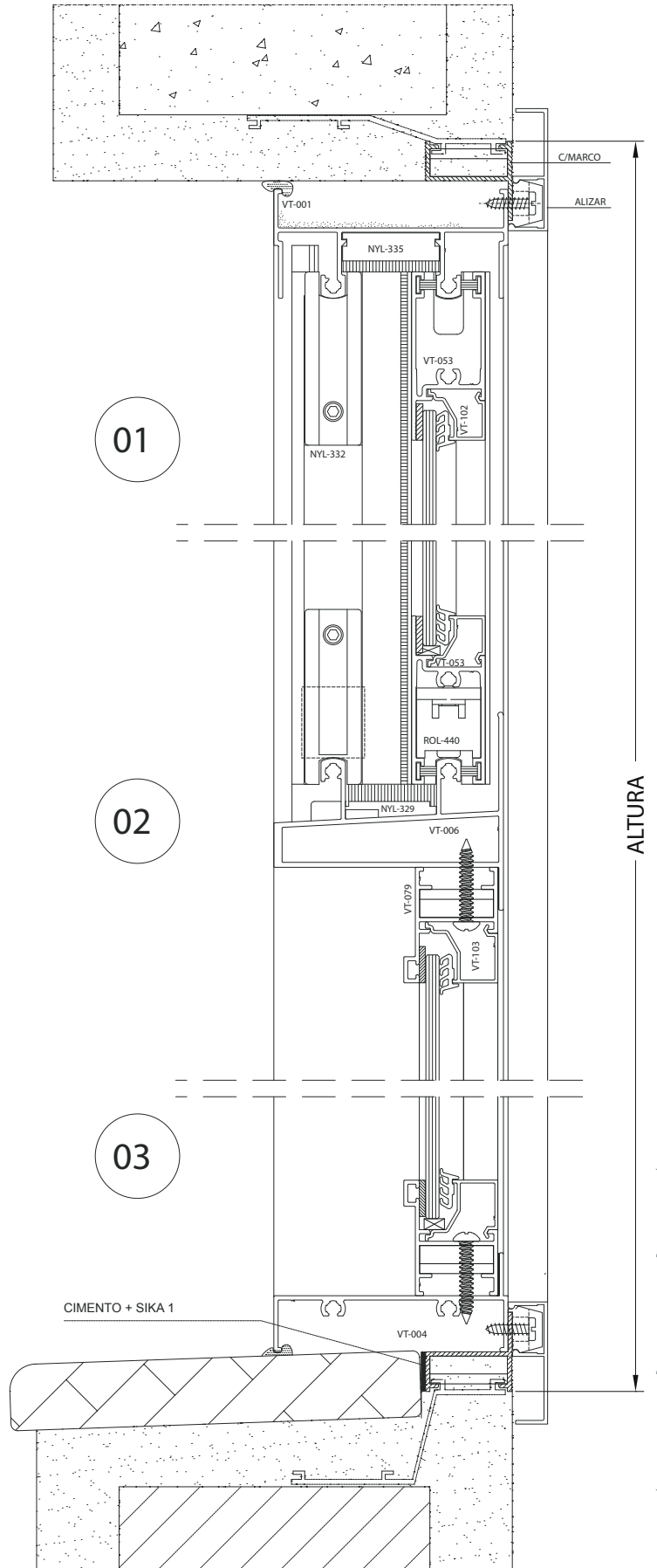

PERFIS, PROJETOS, CÓDIGOS E SISTEMAS ESTÃO SUJEITOS A ALTERAÇÃO SEM AVISO PRÉVIO.

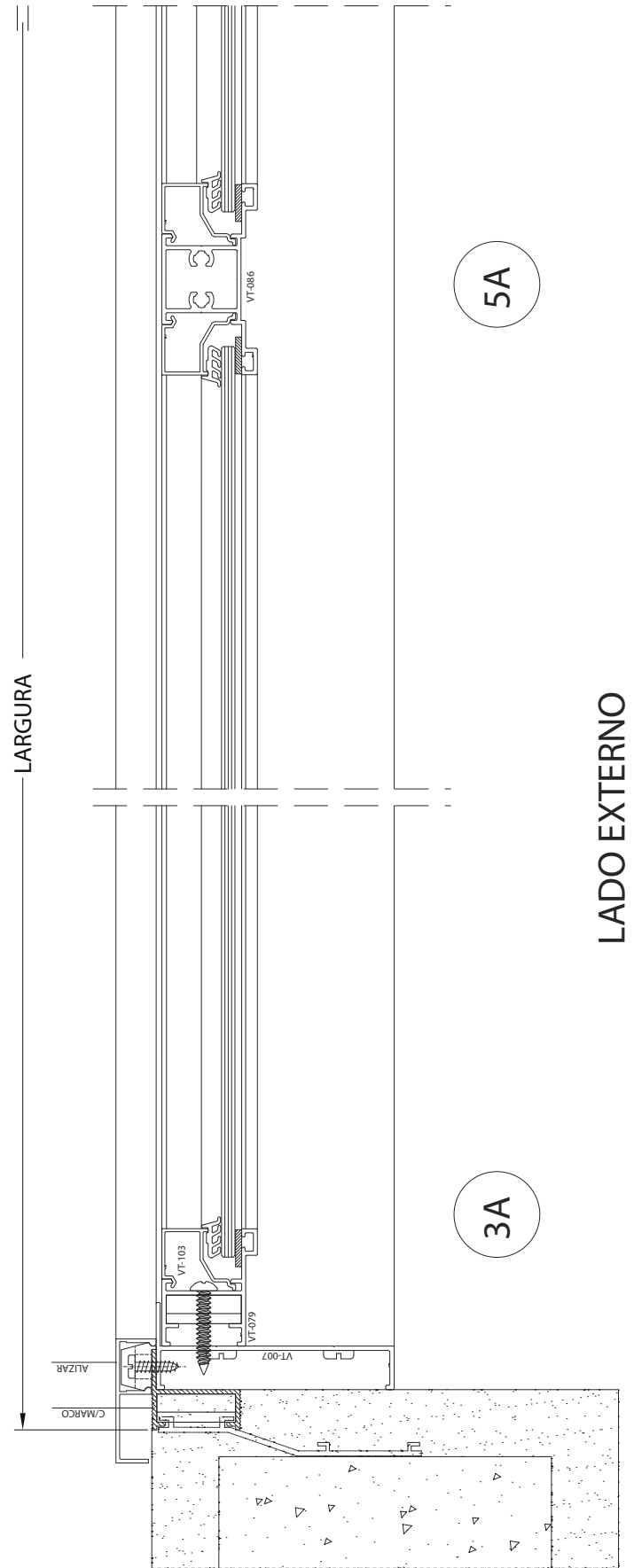
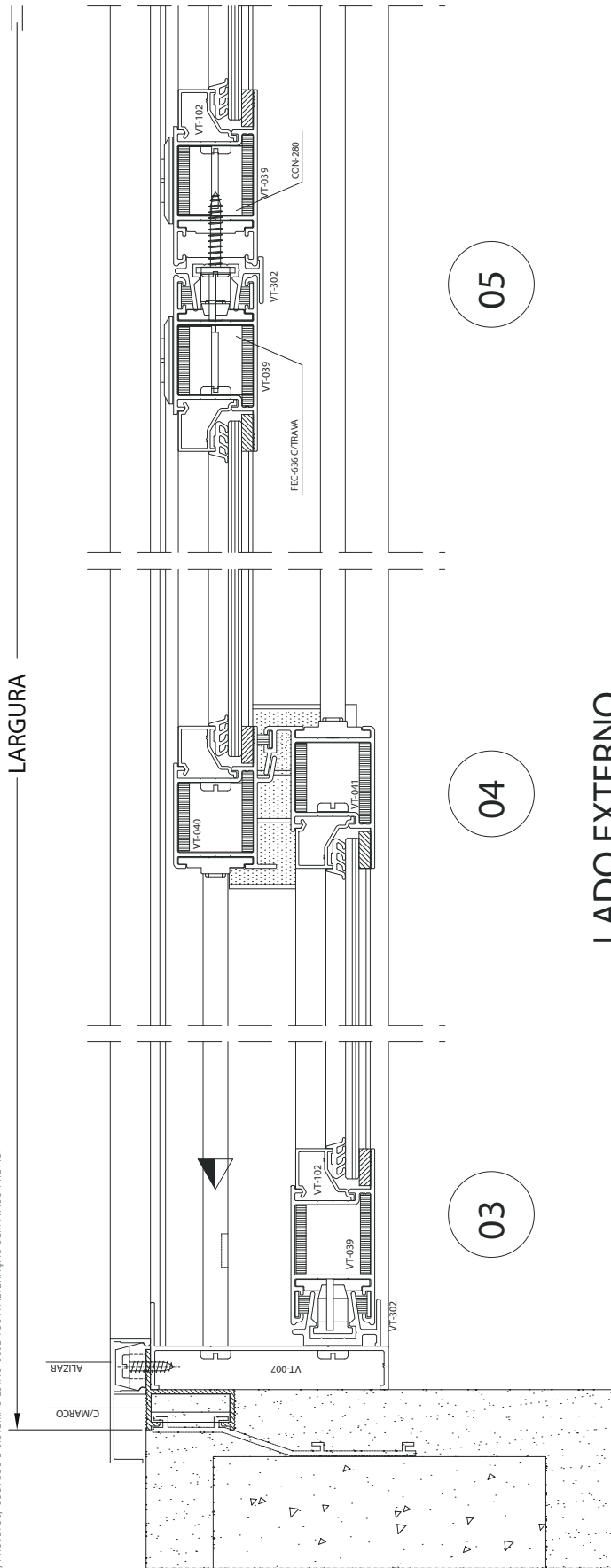

PERFIS, PROJETOS, CÓDIGOS E SISTEMAS ESTÃO SUJEITOS A ALTERAÇÃO SEM AVISO PRÉVIO.

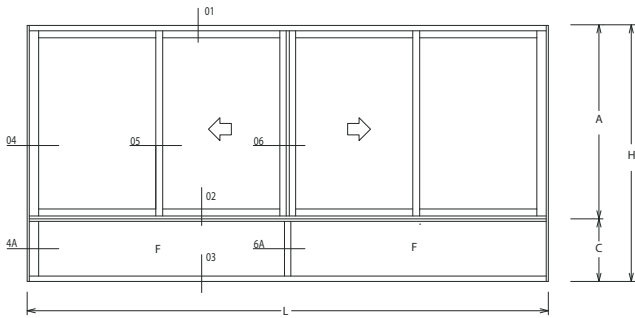

LADO EXTERNO

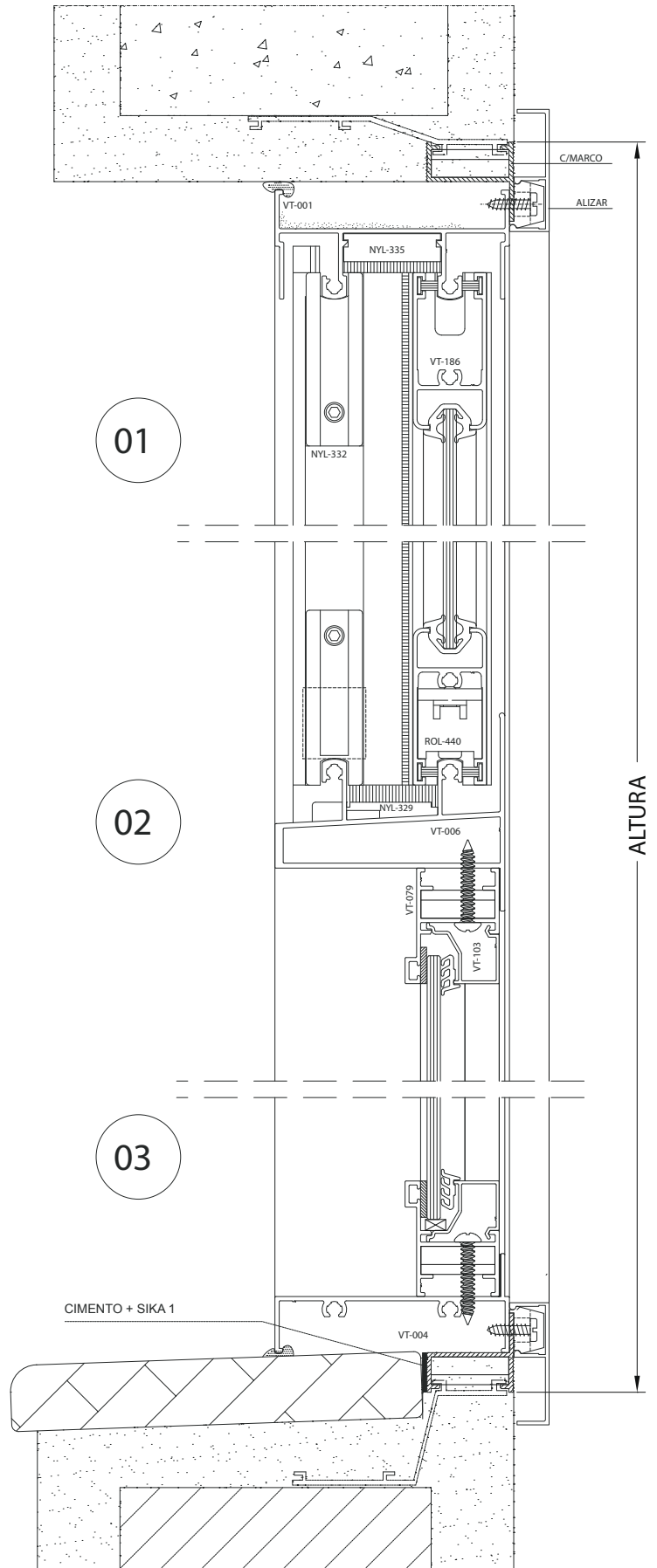

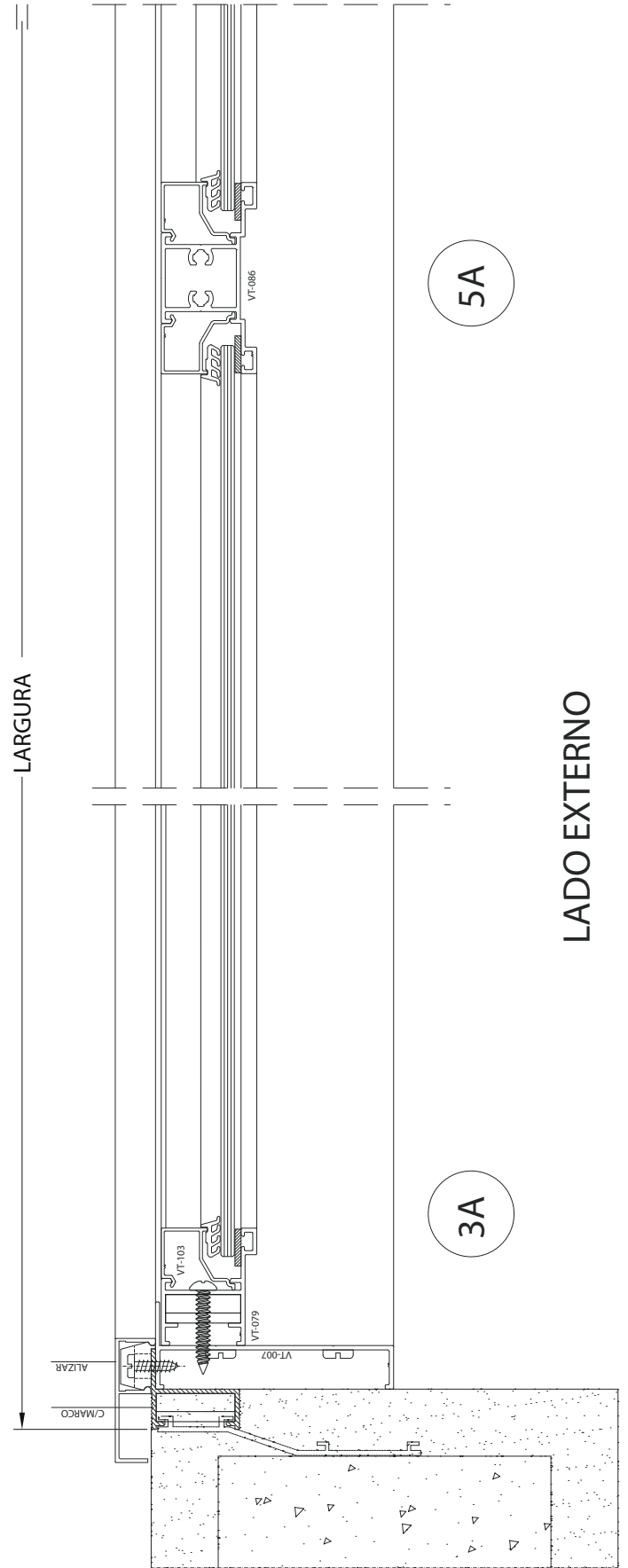
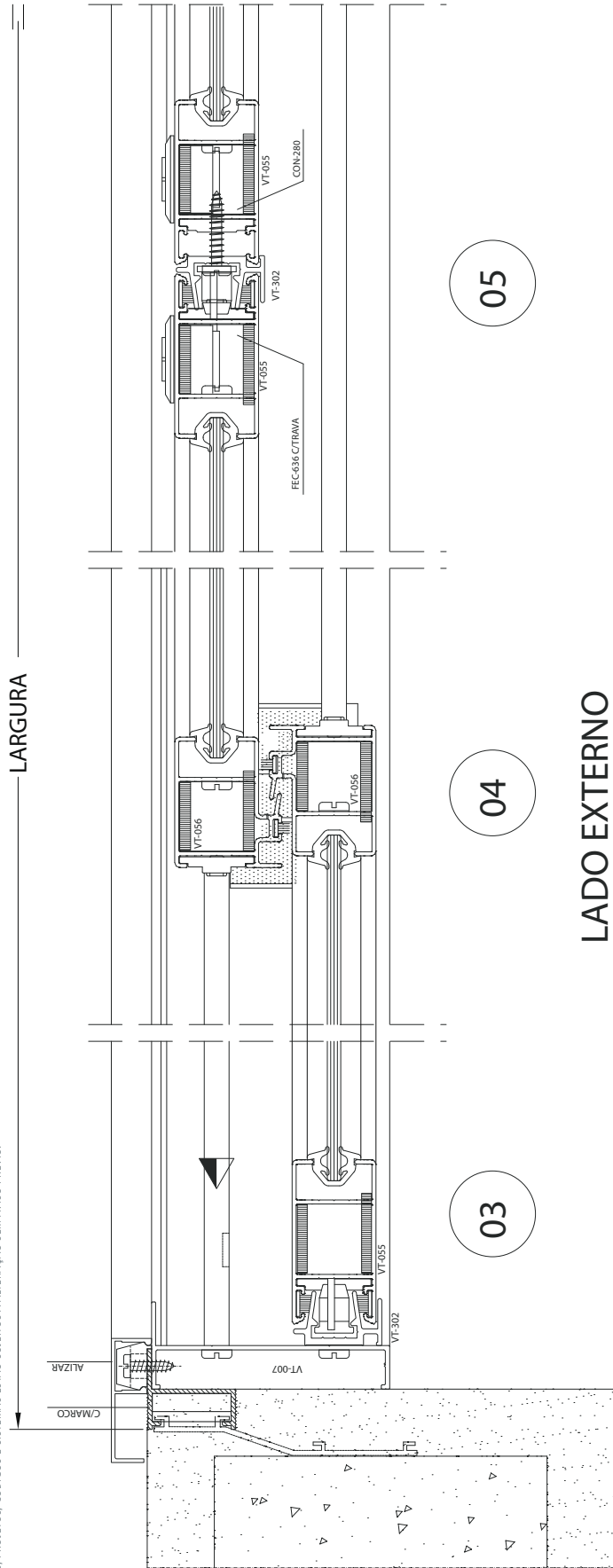

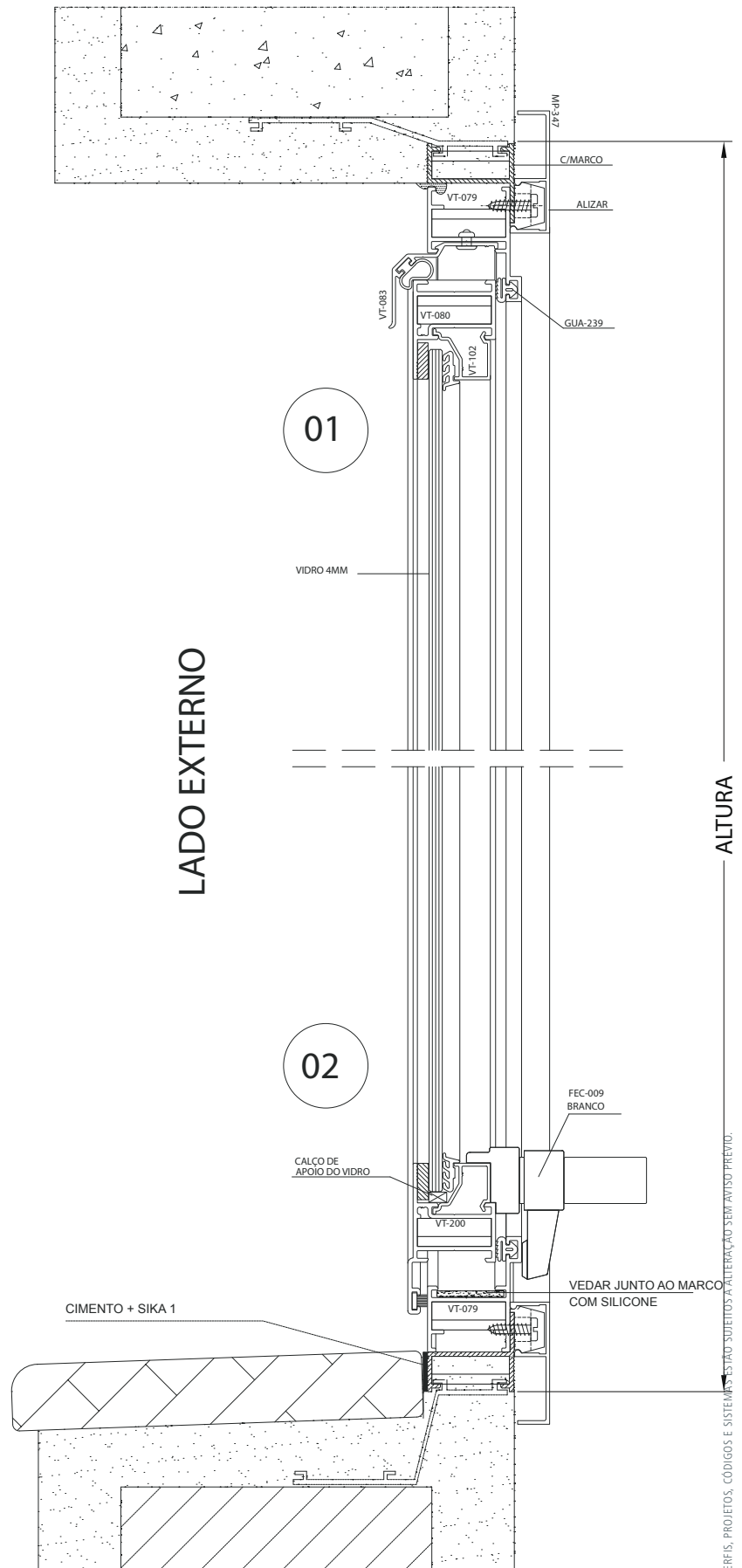
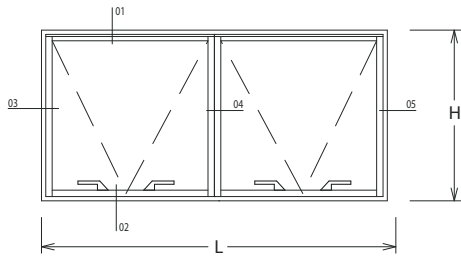

PERFIS, PROJETOS, CÓDIGOS E SISTEMAS ESTÃO SUJEITOS A ALTERAÇÃO SEM AVISO PRÉVIO.

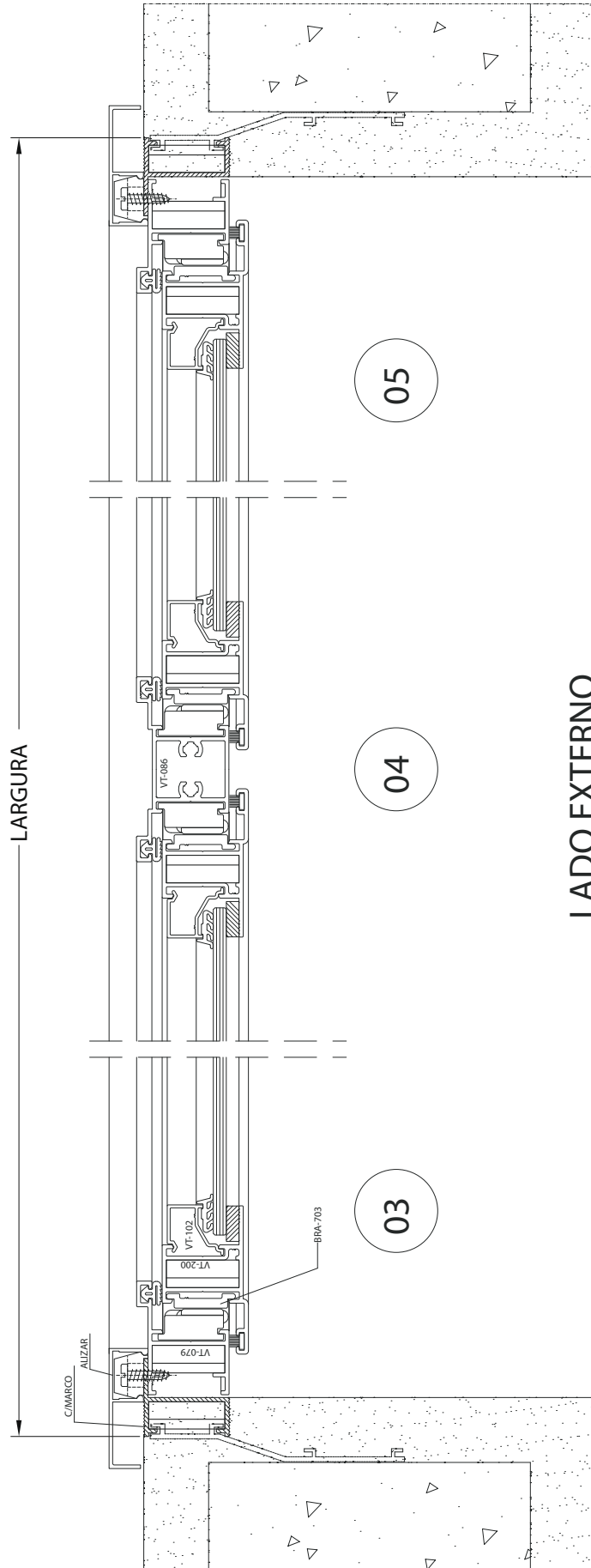

LADO EXTERNO

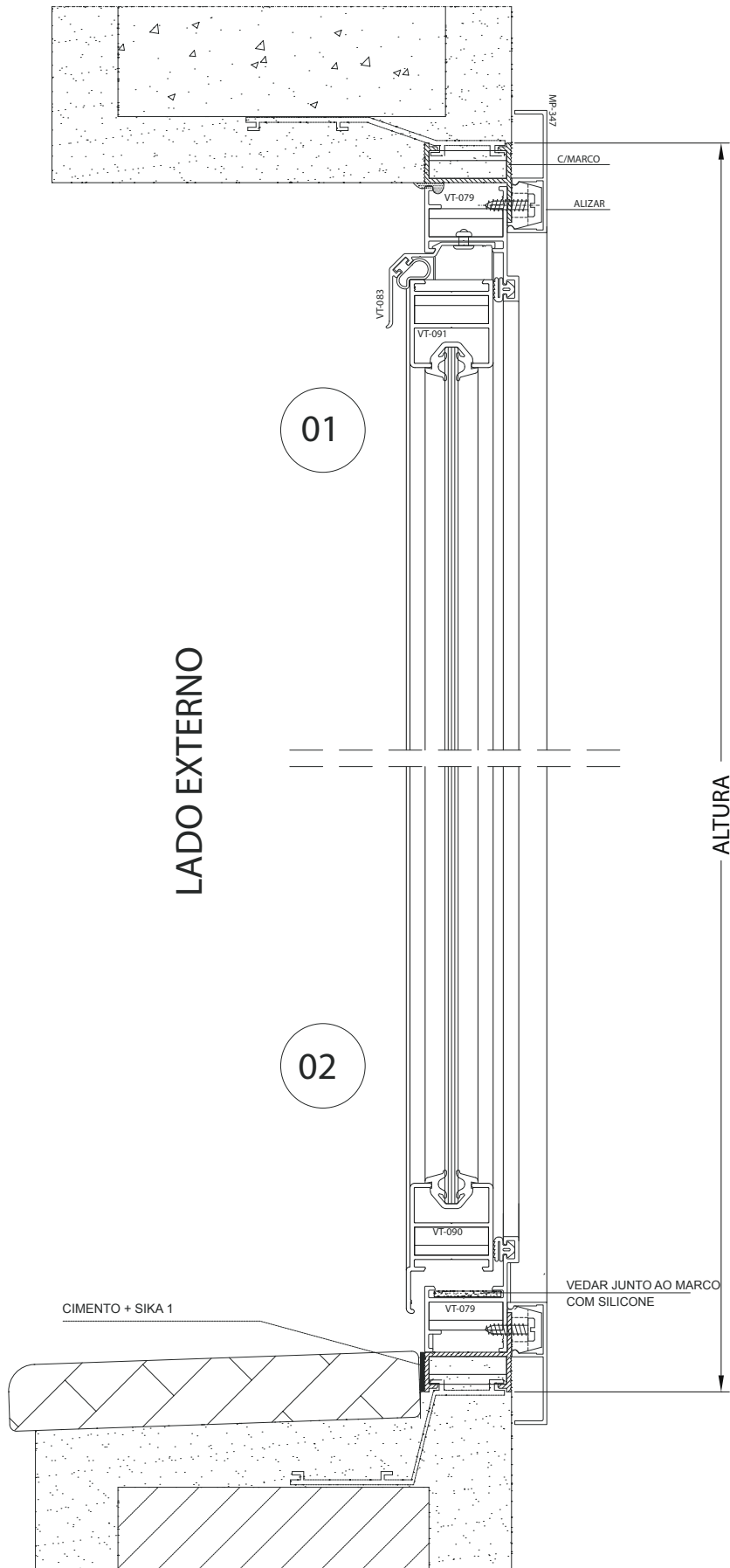
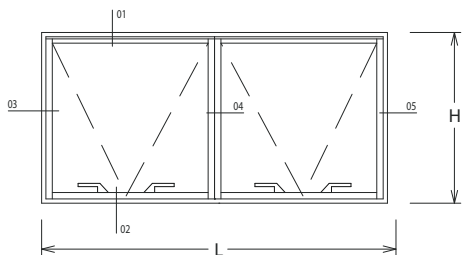

PERFIS, PROJETOS, CÓDIGOS E SISTEMAS ESTÃO SUJEITOS A ALTERAÇÃO SEM AVISO PRÉVIO.

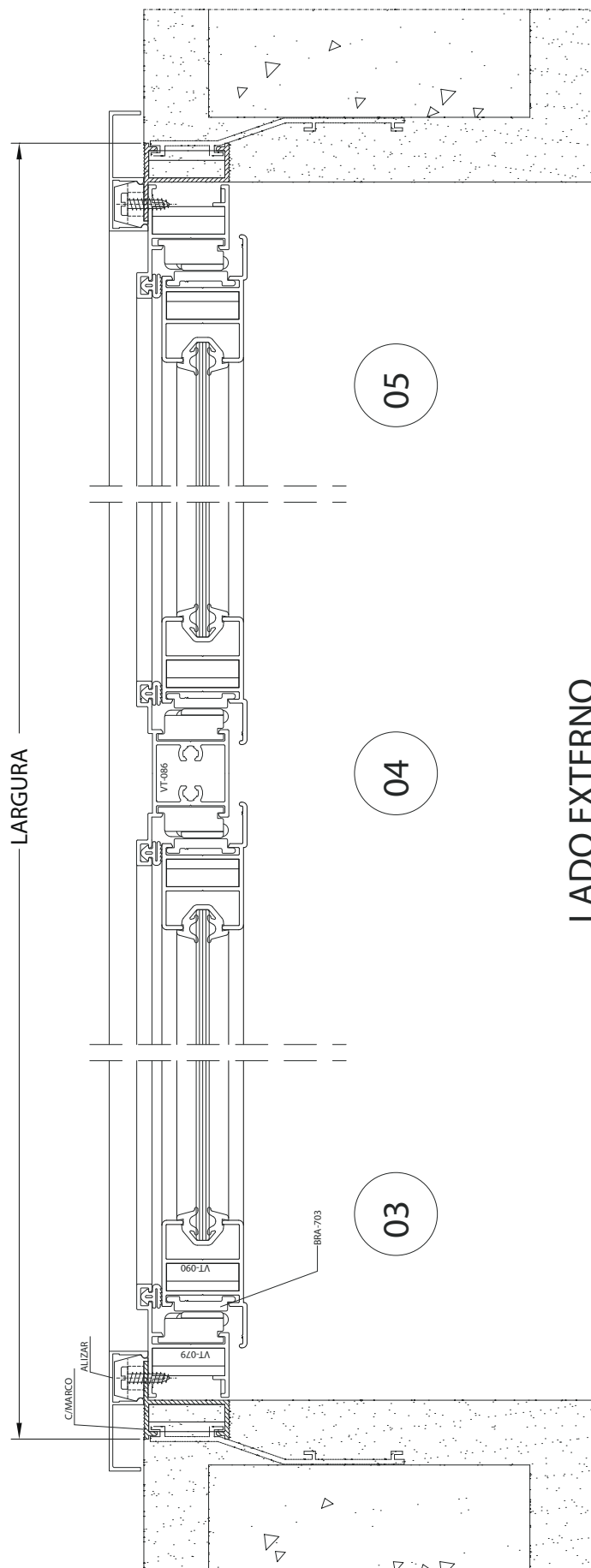

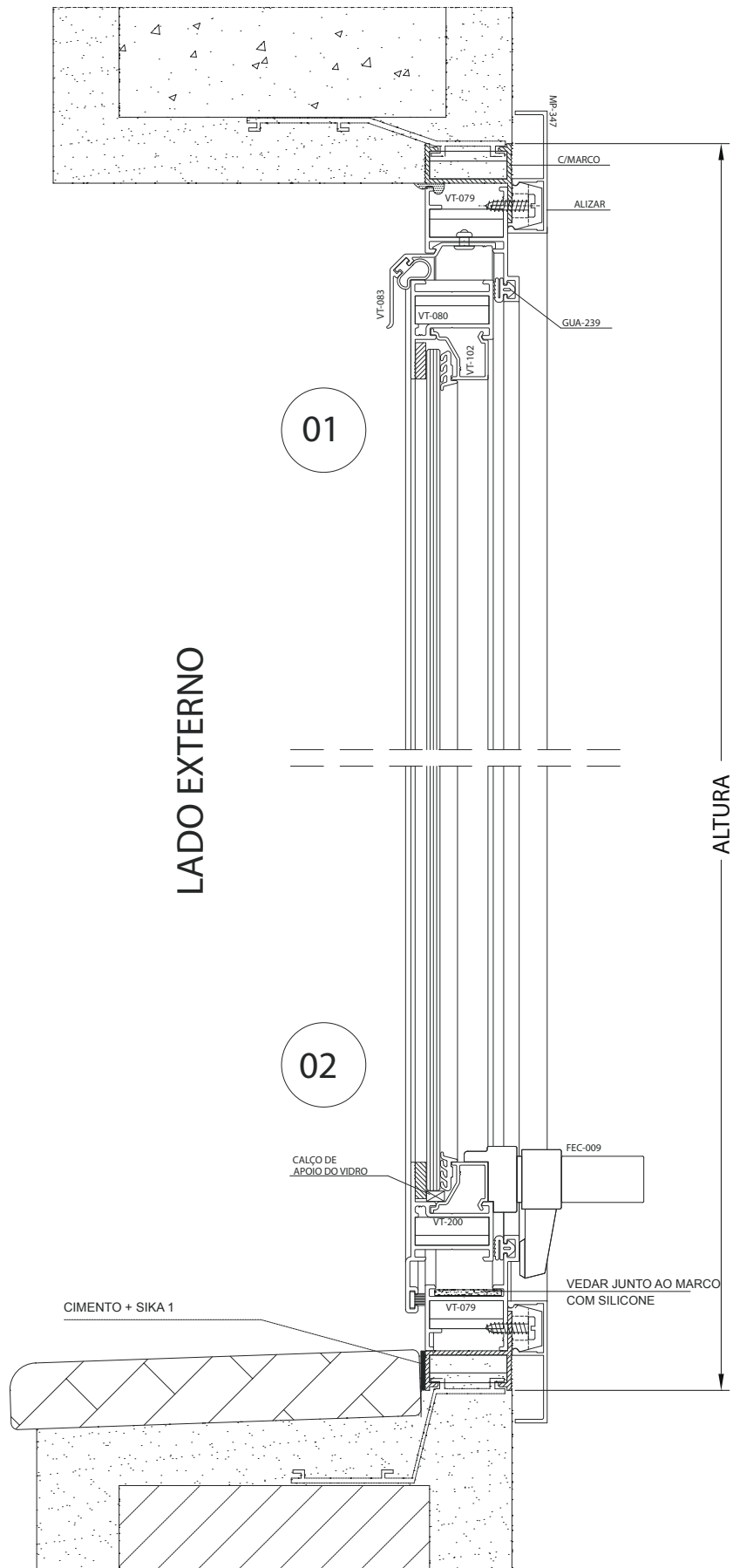
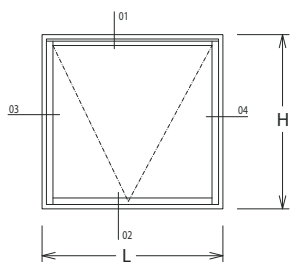

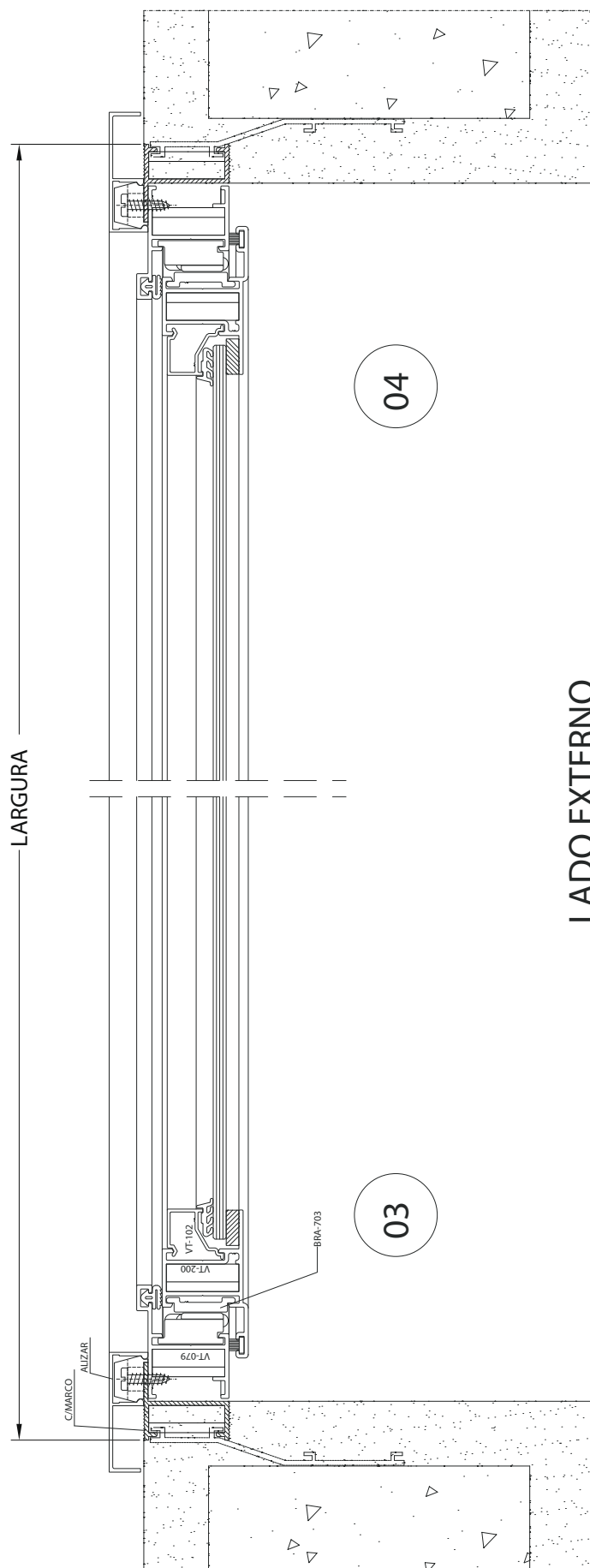

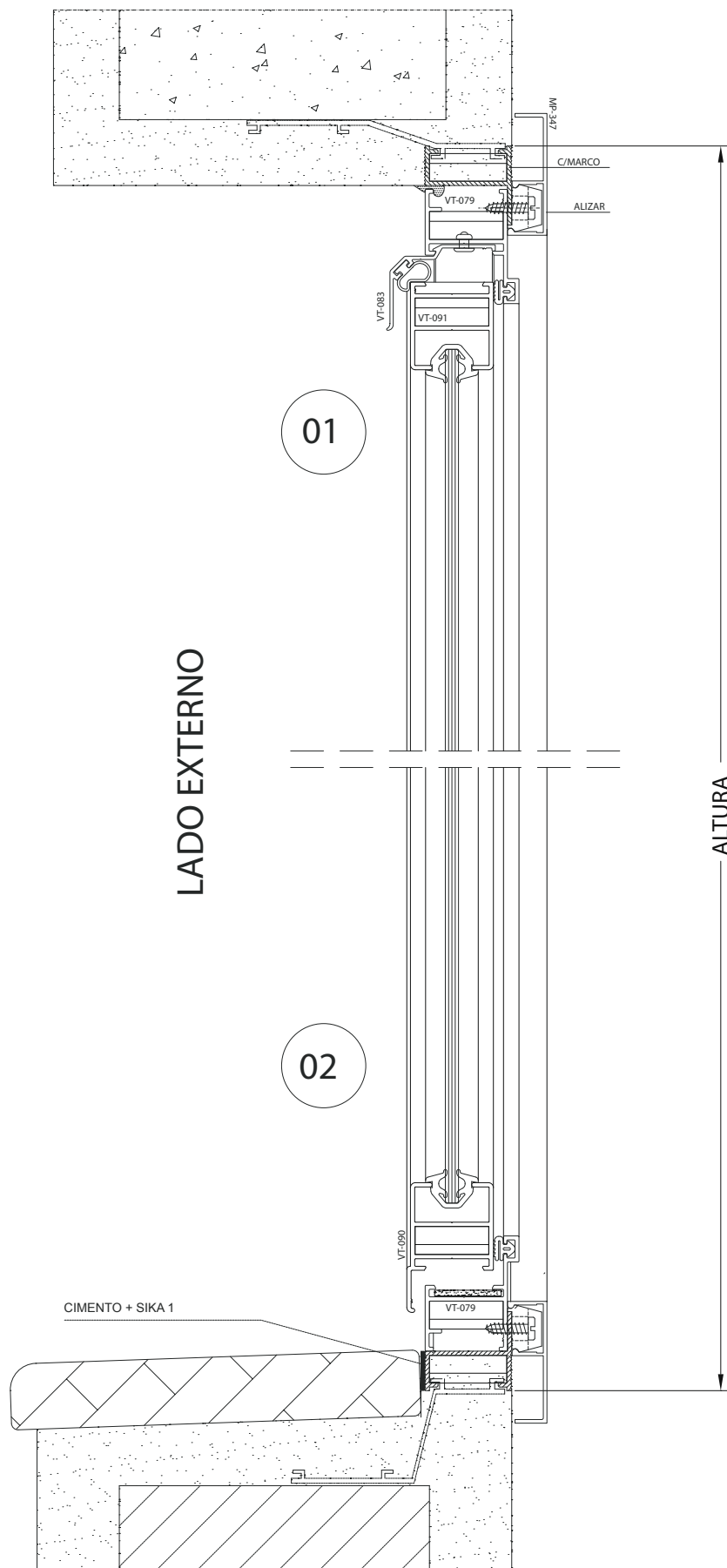
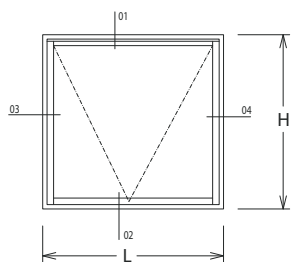

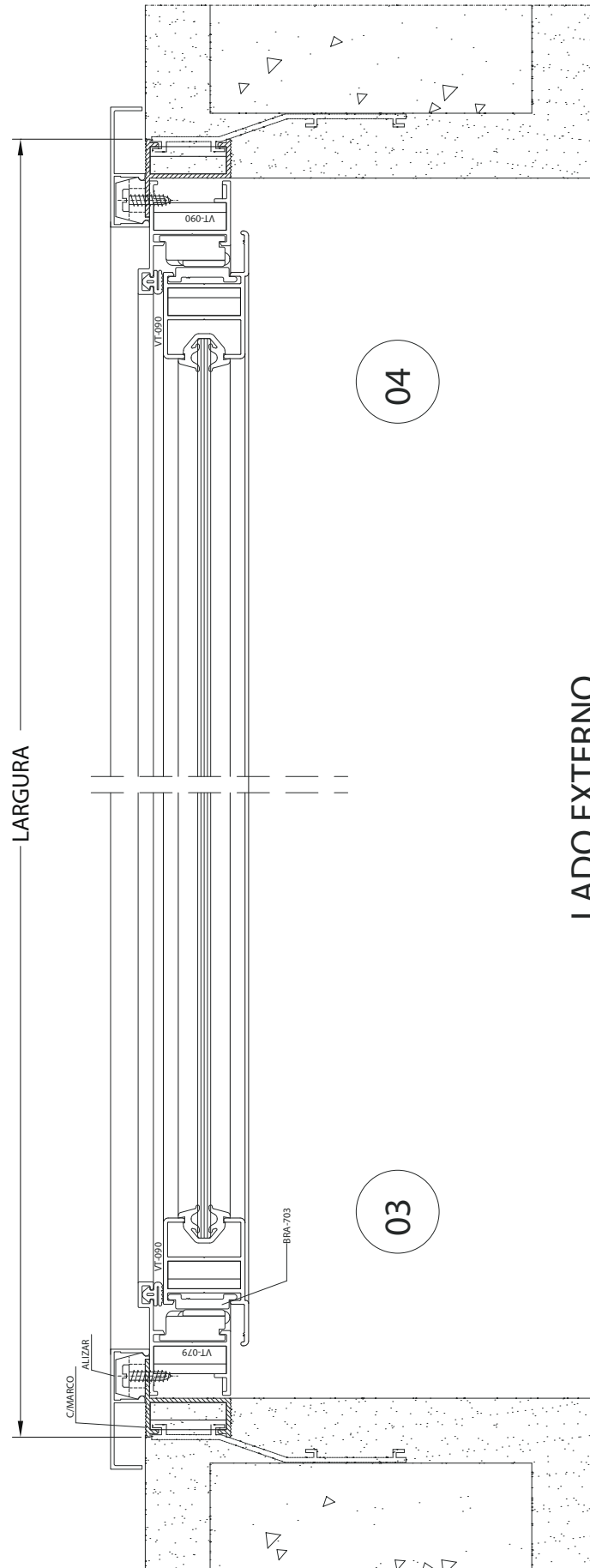

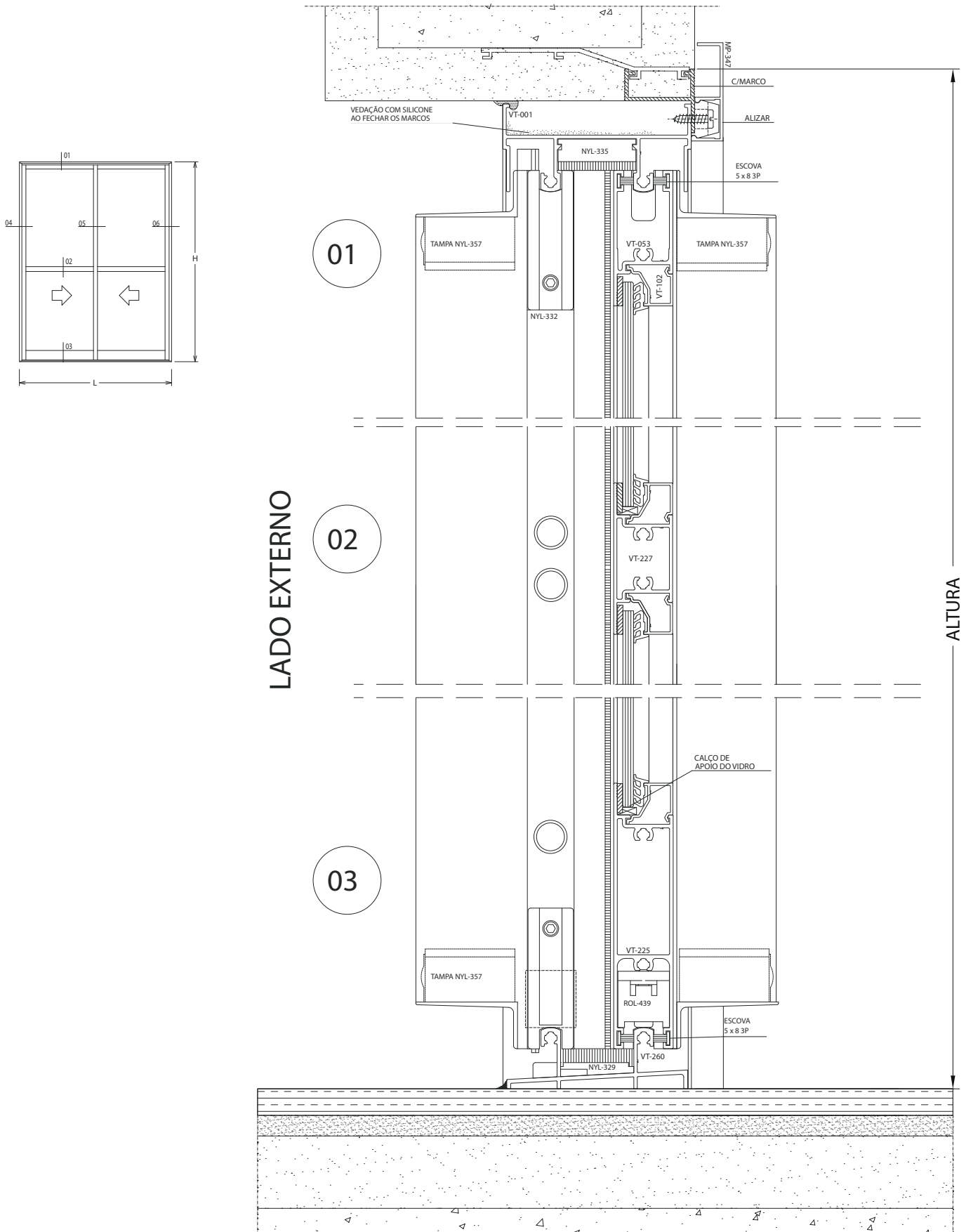

PERFIS, PROJETOS, CÓDIGOS E SISTEMAS ESTÃO SUJEITOS A ALTERAÇÃO SEM AVISO PRÉVIO.

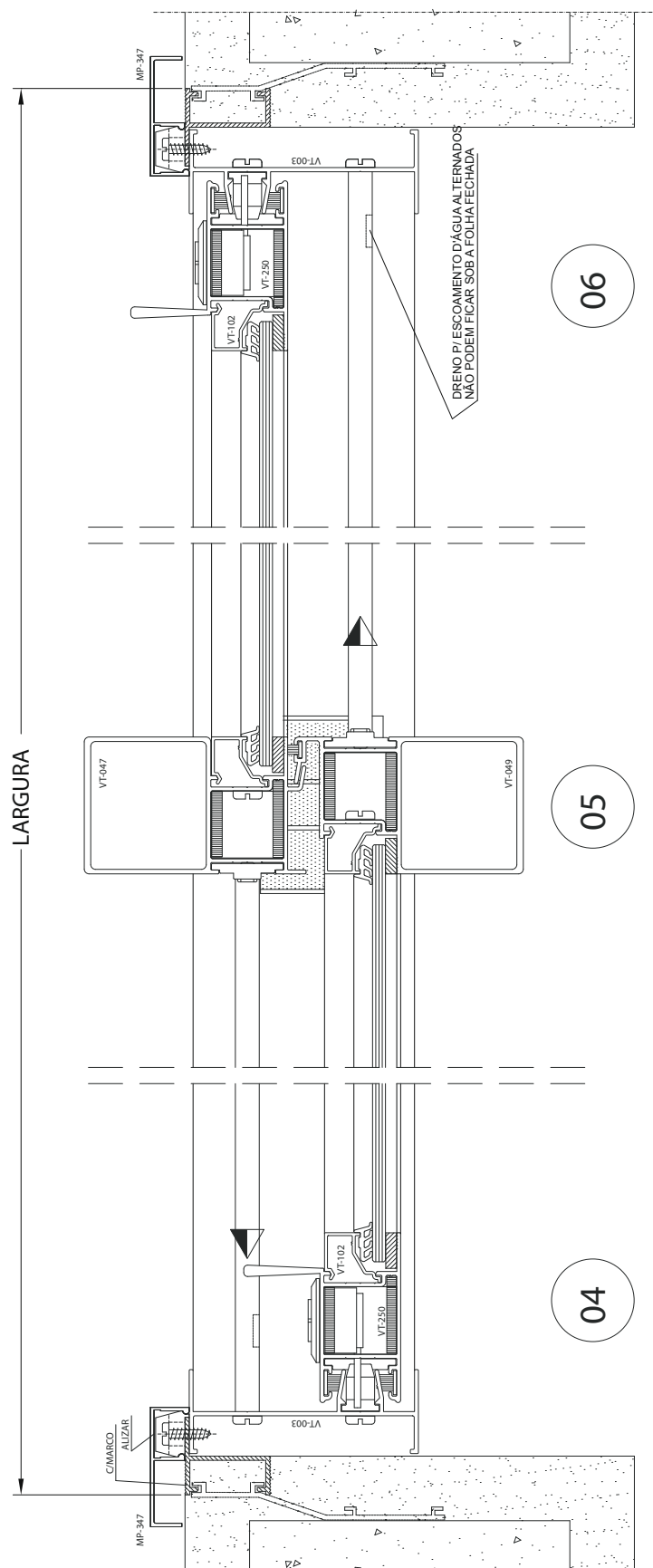

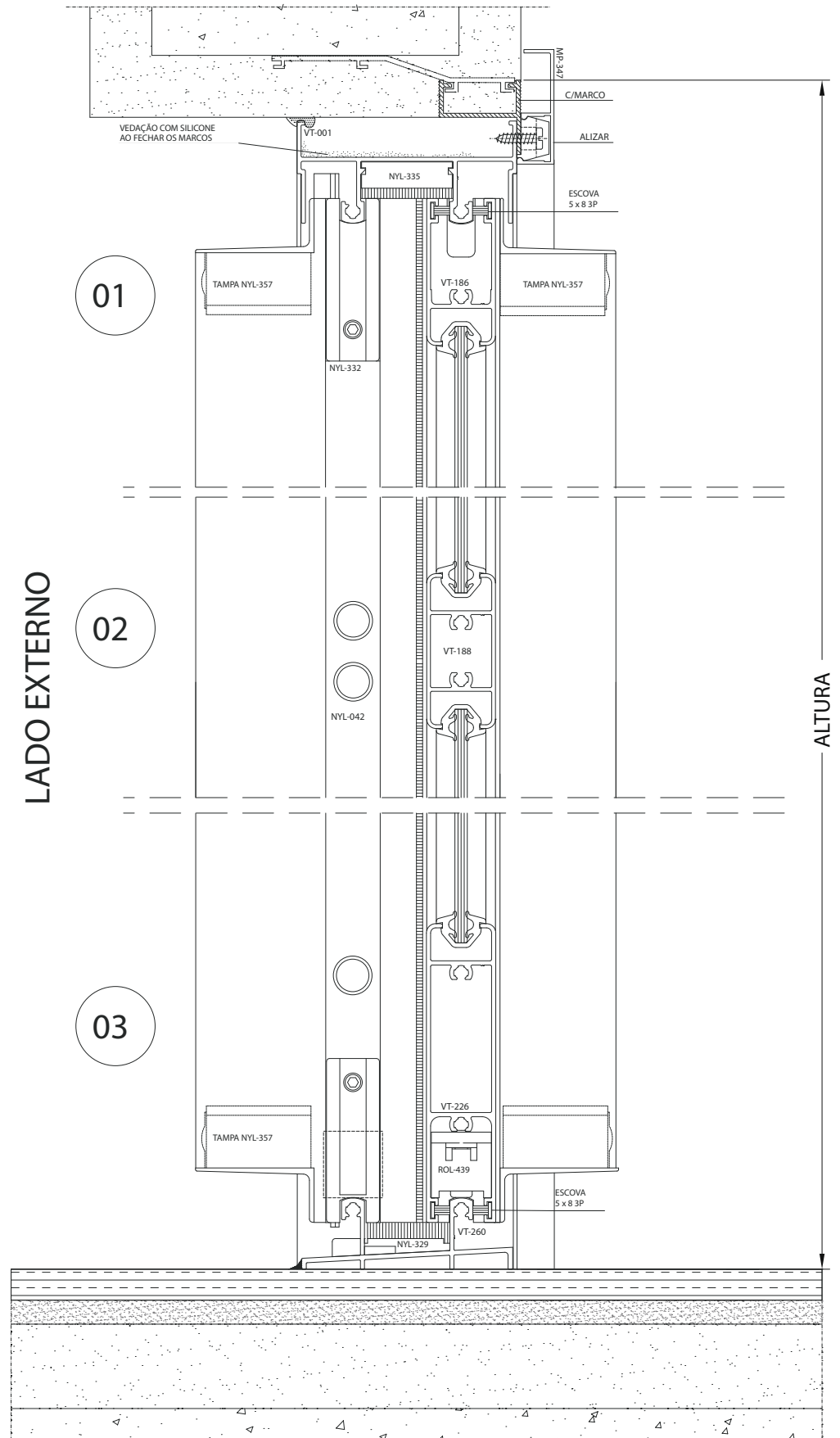
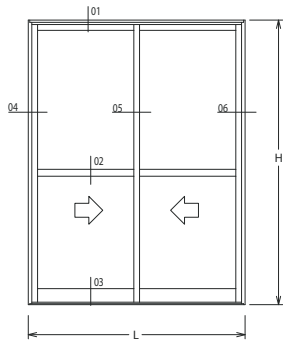

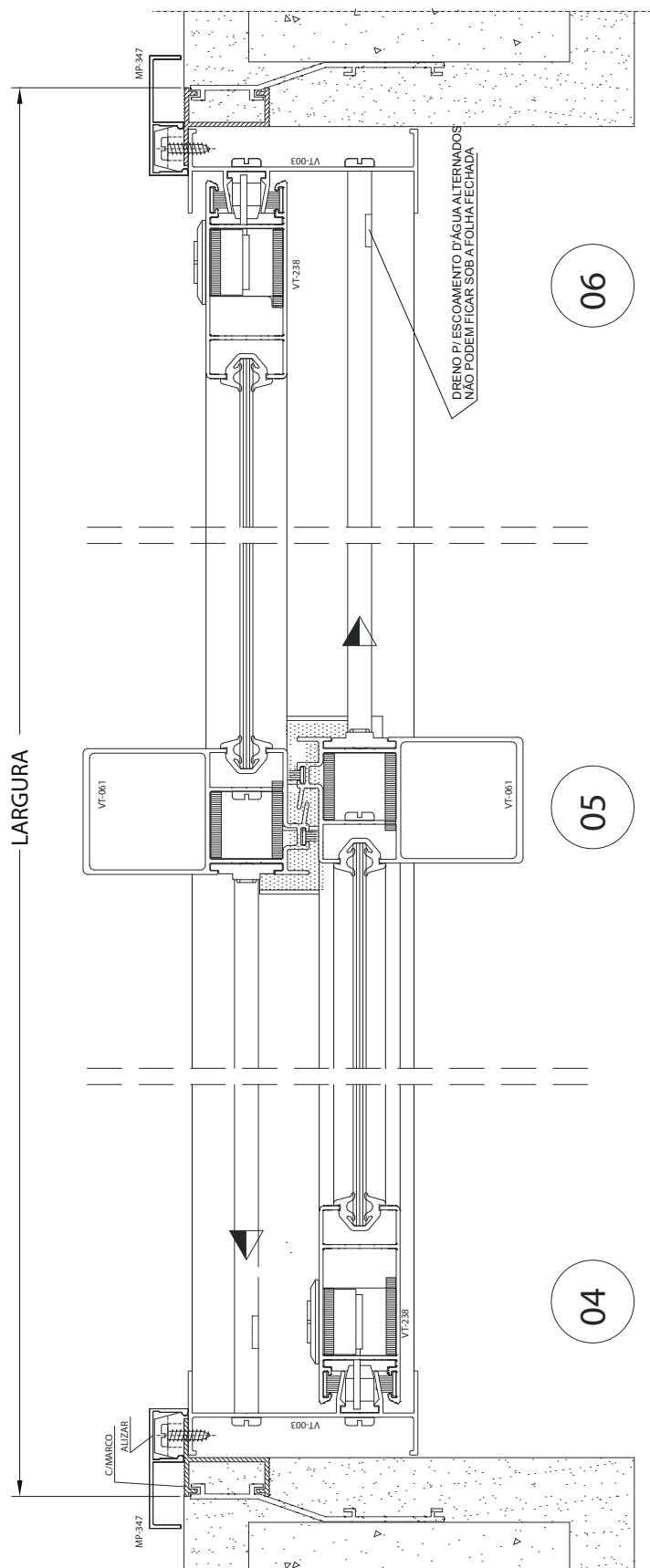

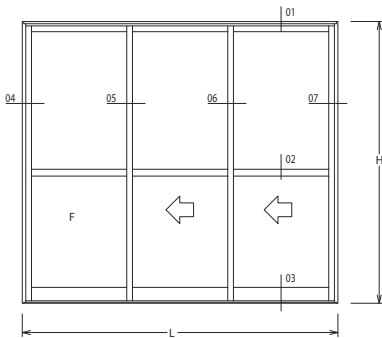

LADO EXTERNO

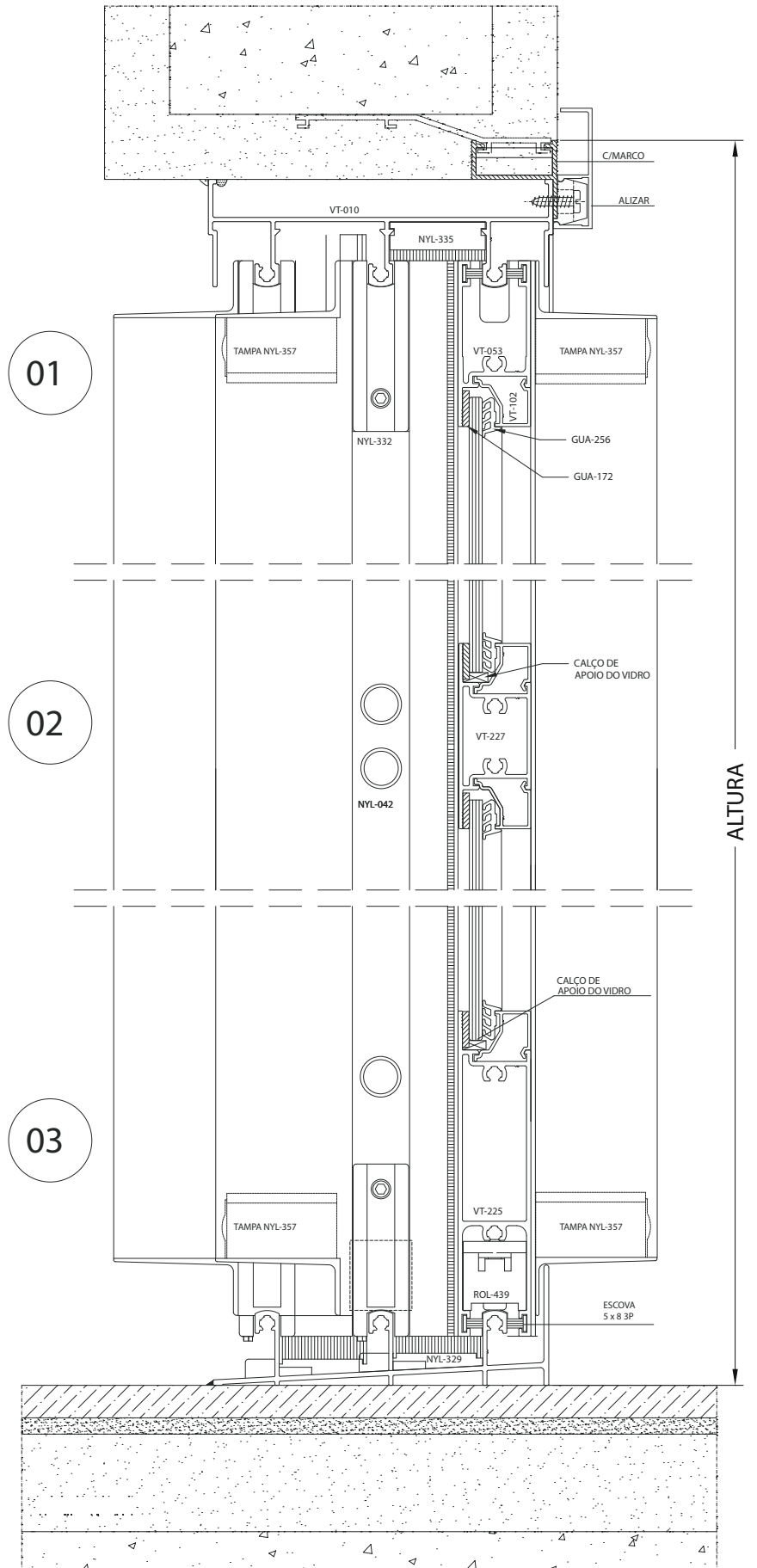

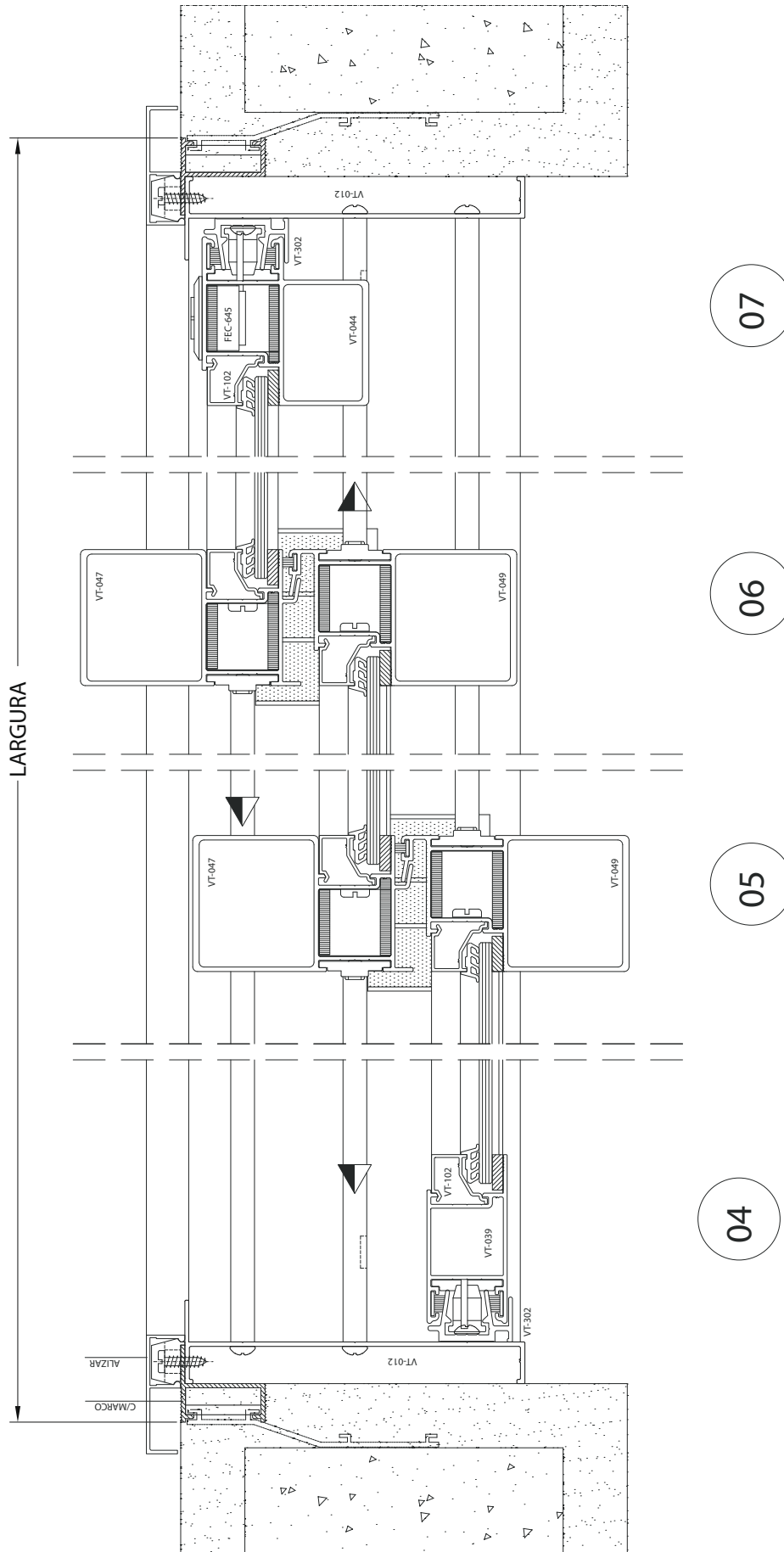

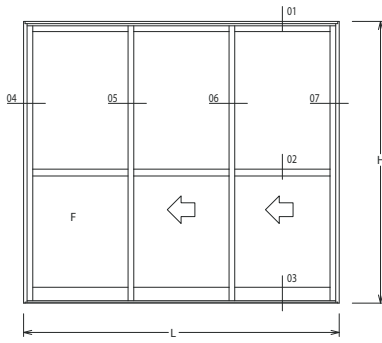

LADO EXTERNO

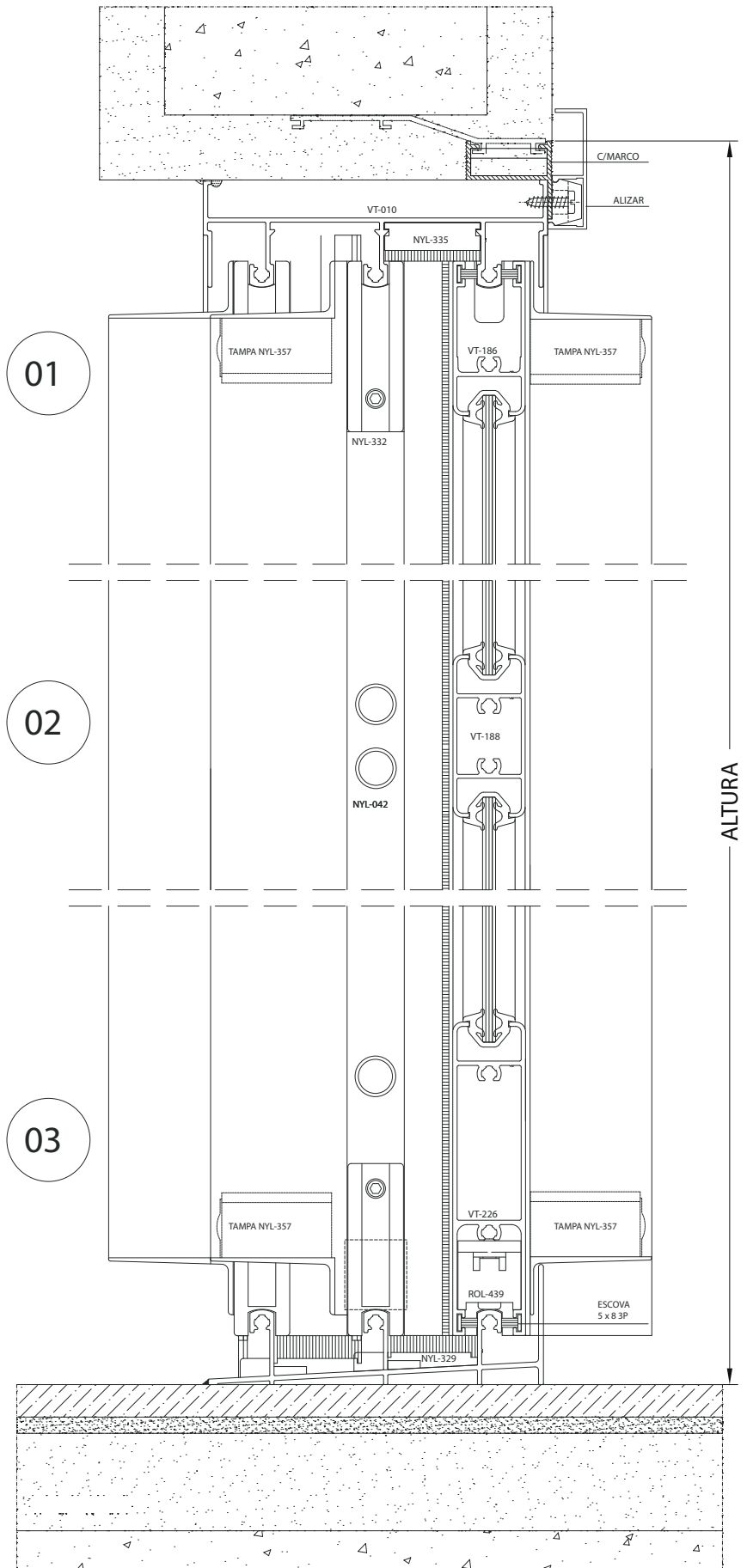

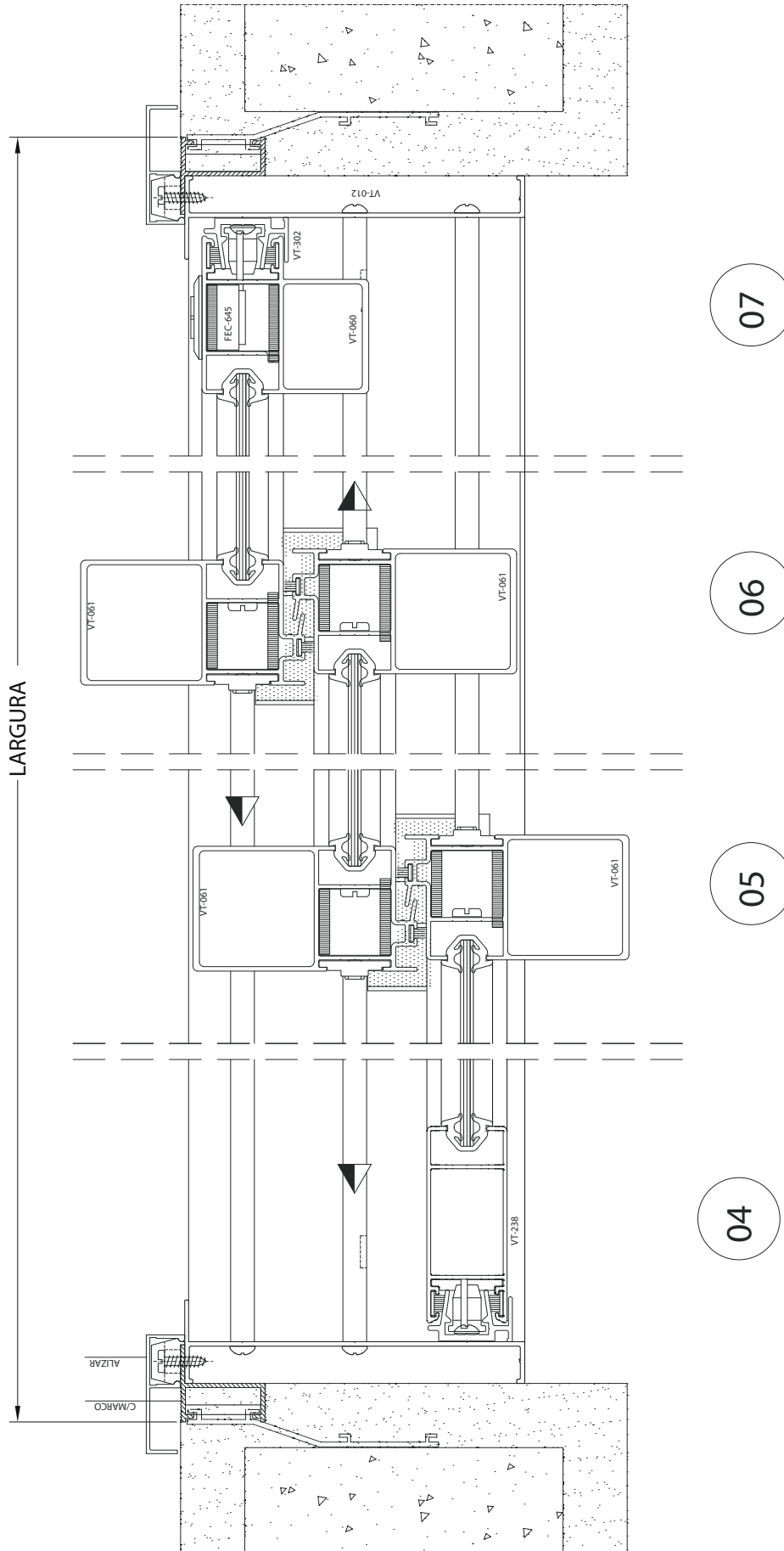

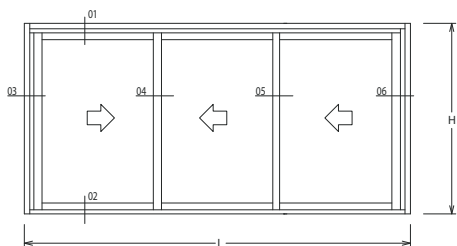

LADO EXTERNO

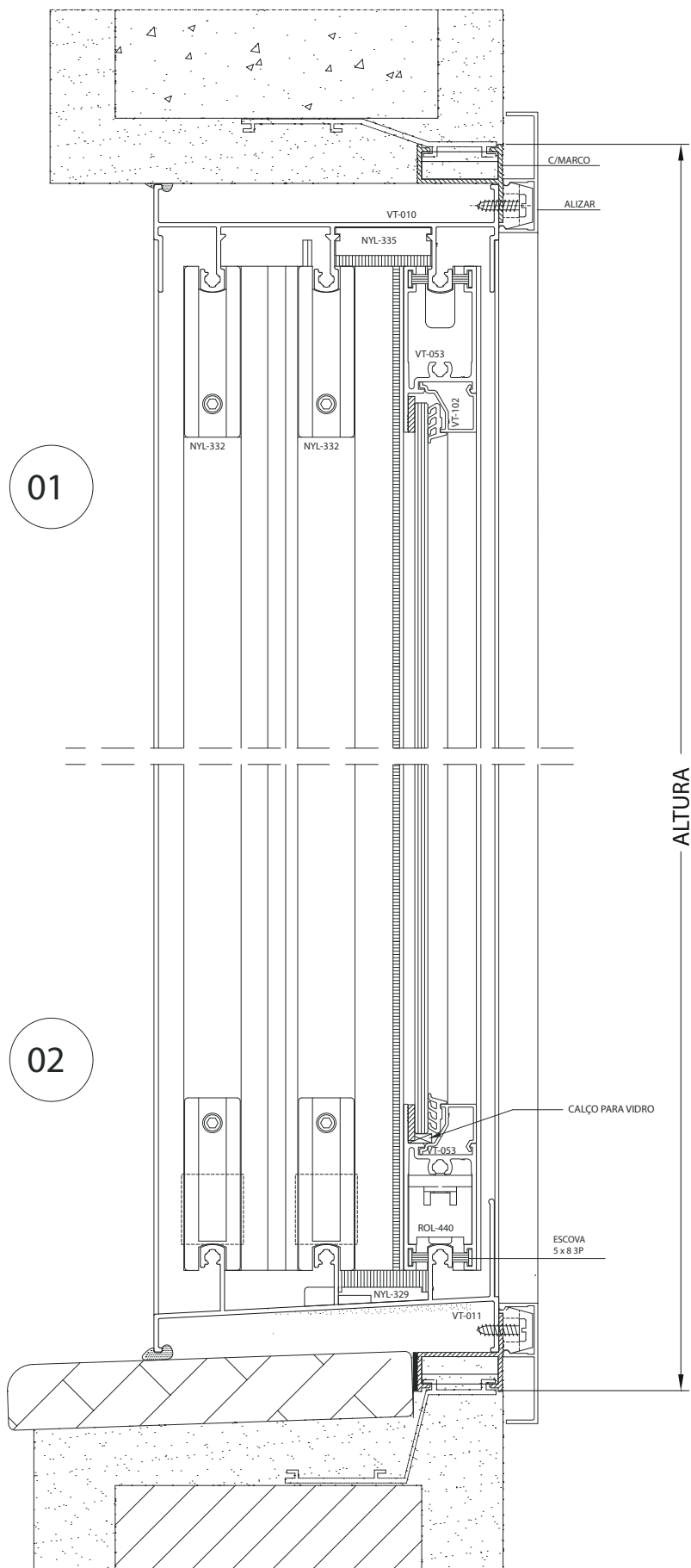

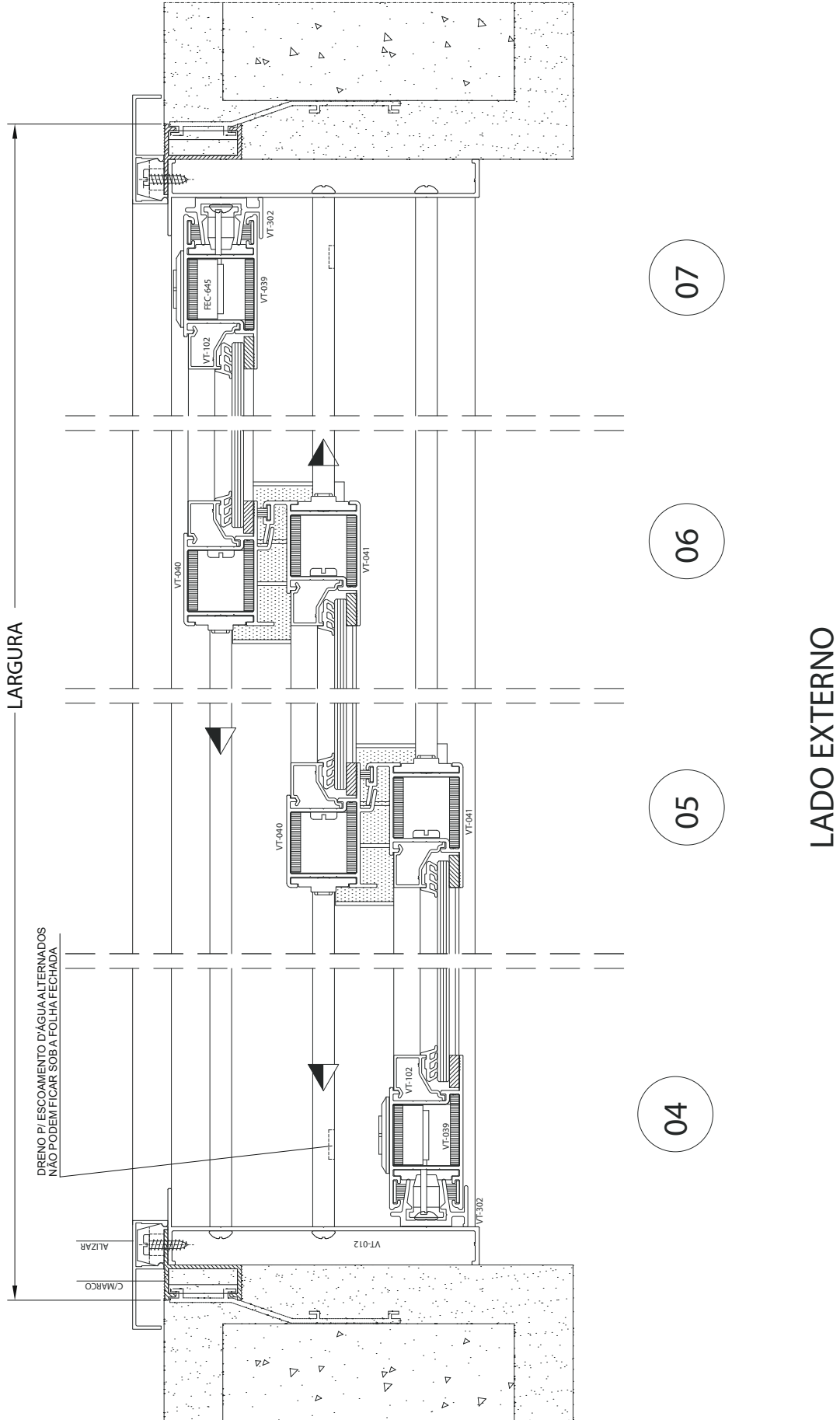

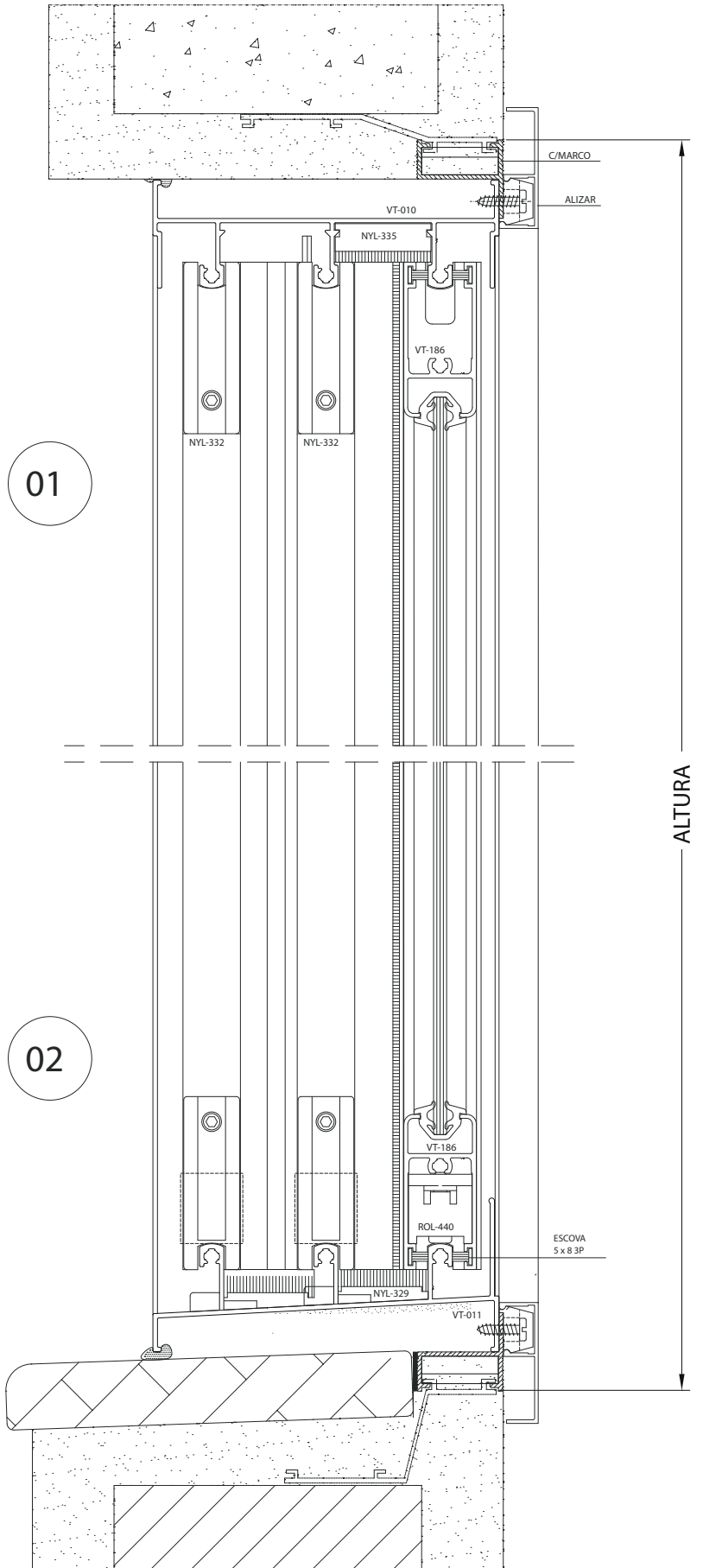
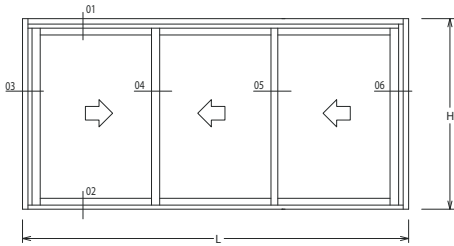

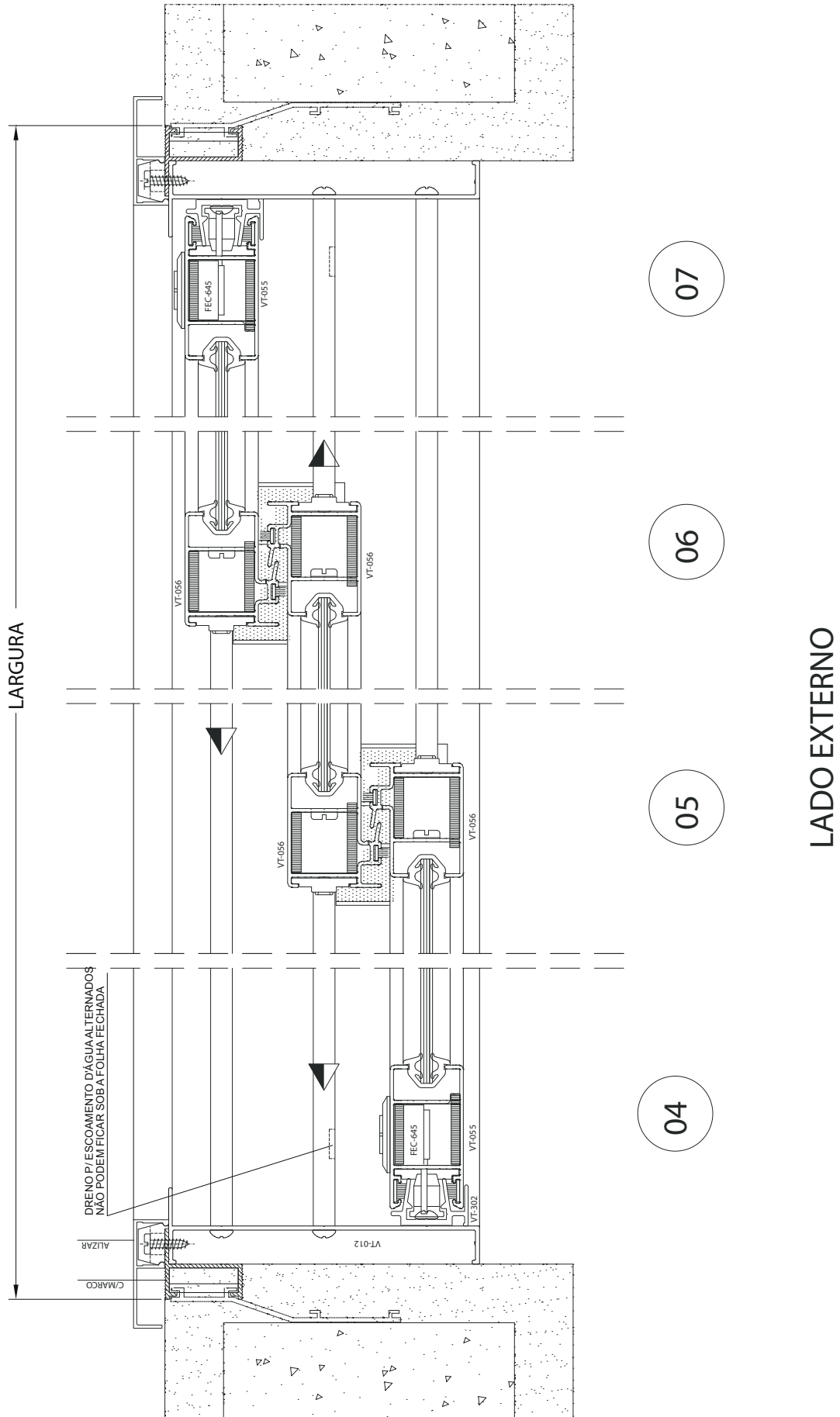

PERFIS, PROJETOS, CÓDIGOS E SISTEMAS ESTÃO SUJEITOS A ALTERAÇÃO SEM AVISO PRÉVIO.

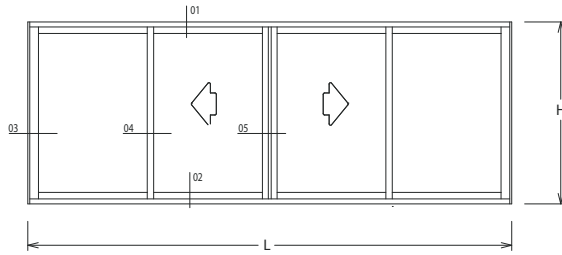

LADO EXTERNO

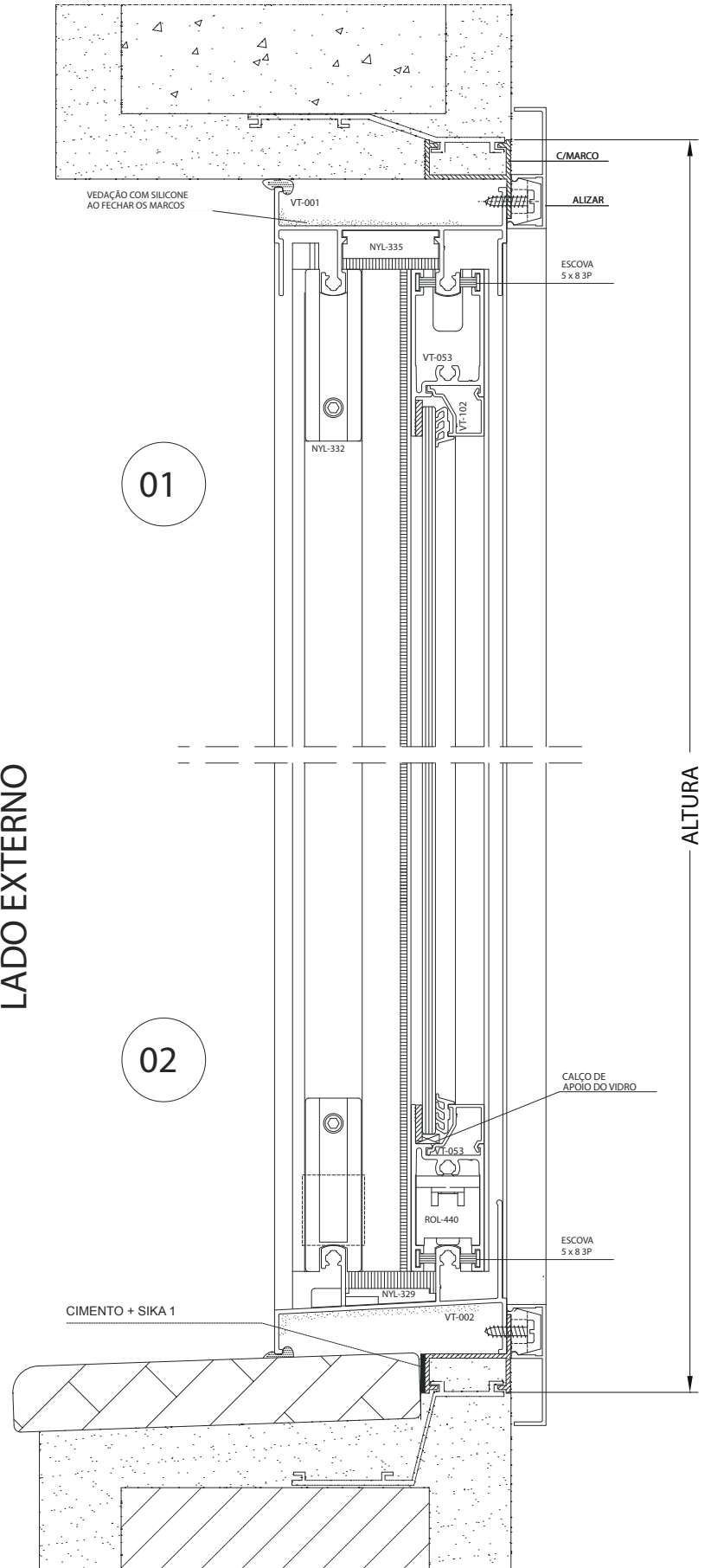

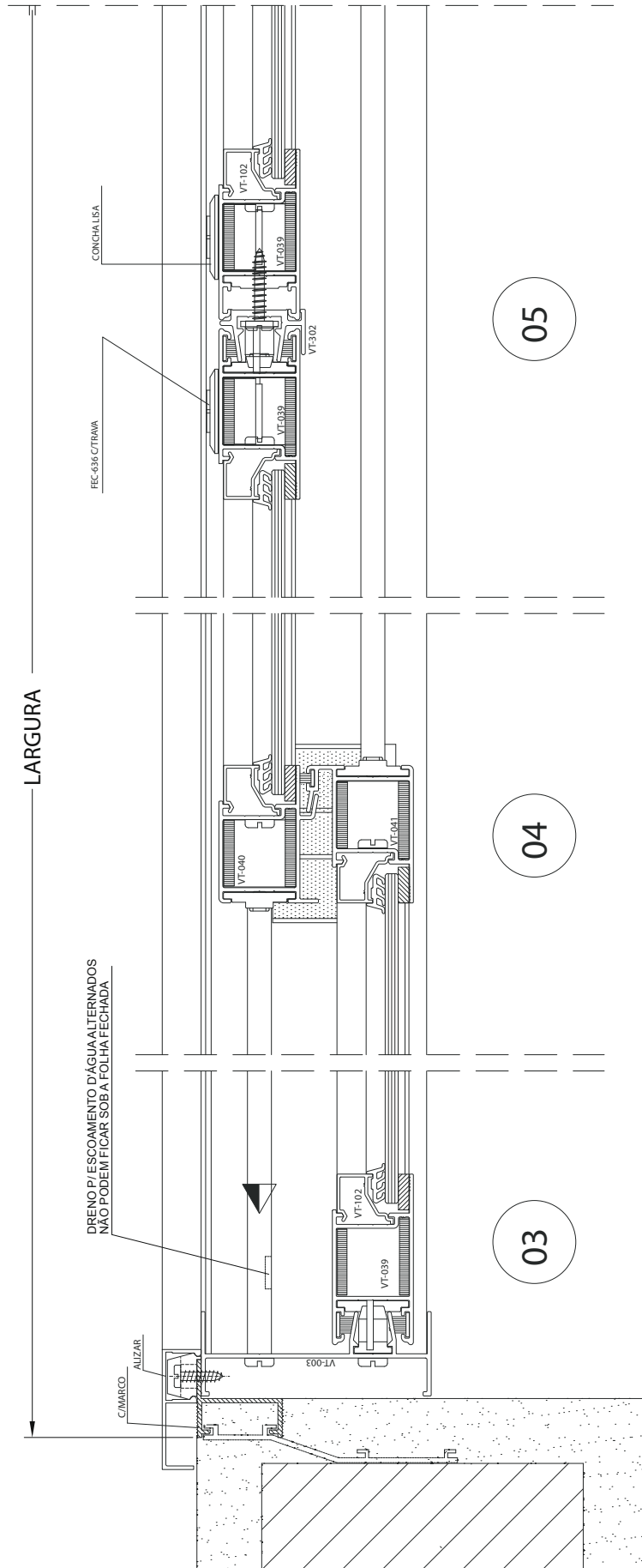

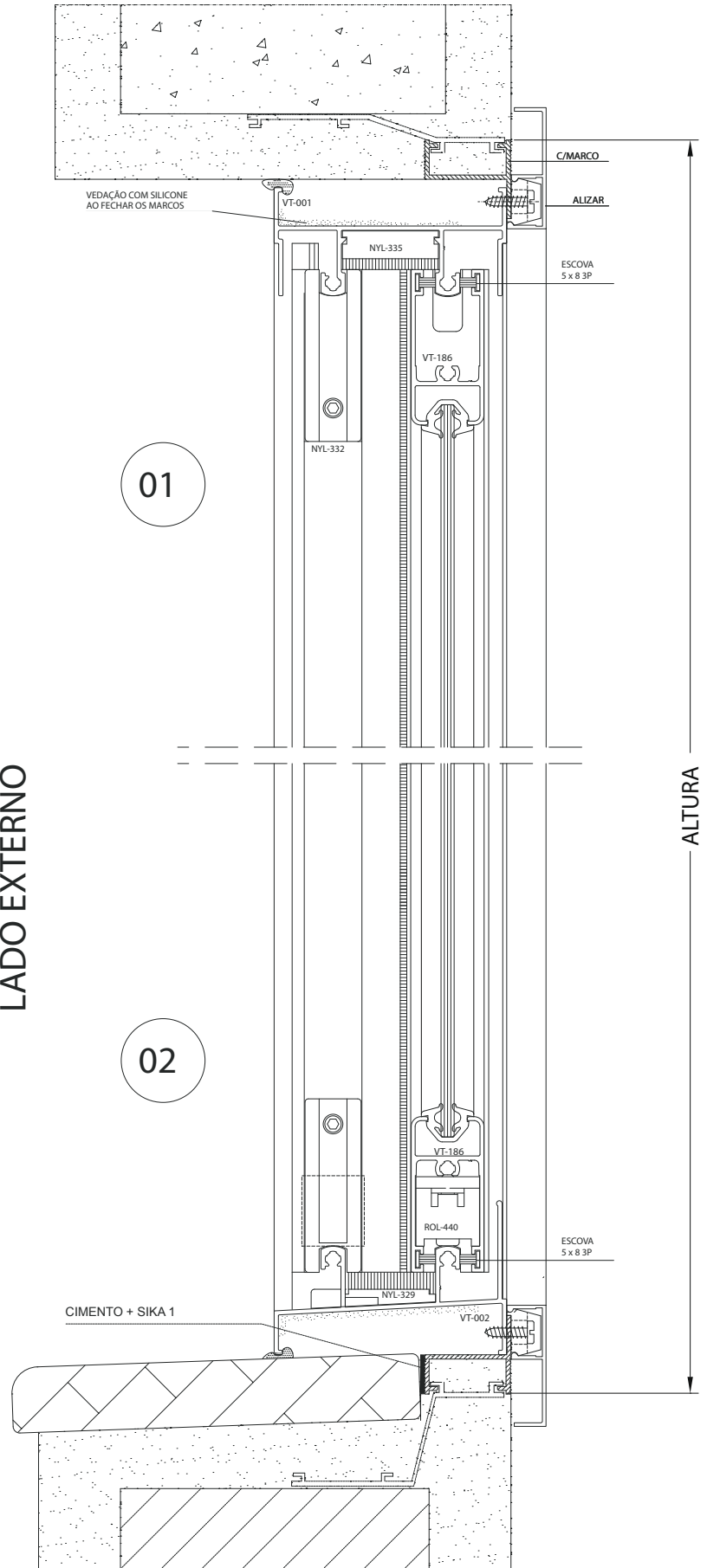
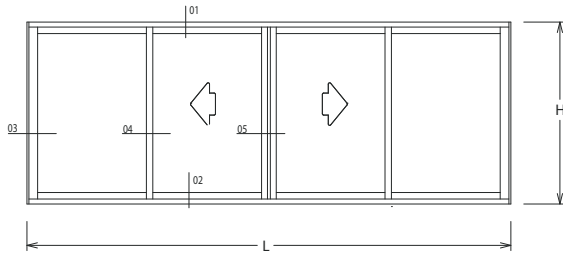

01

02

LADO EXTERNO

ALTURA

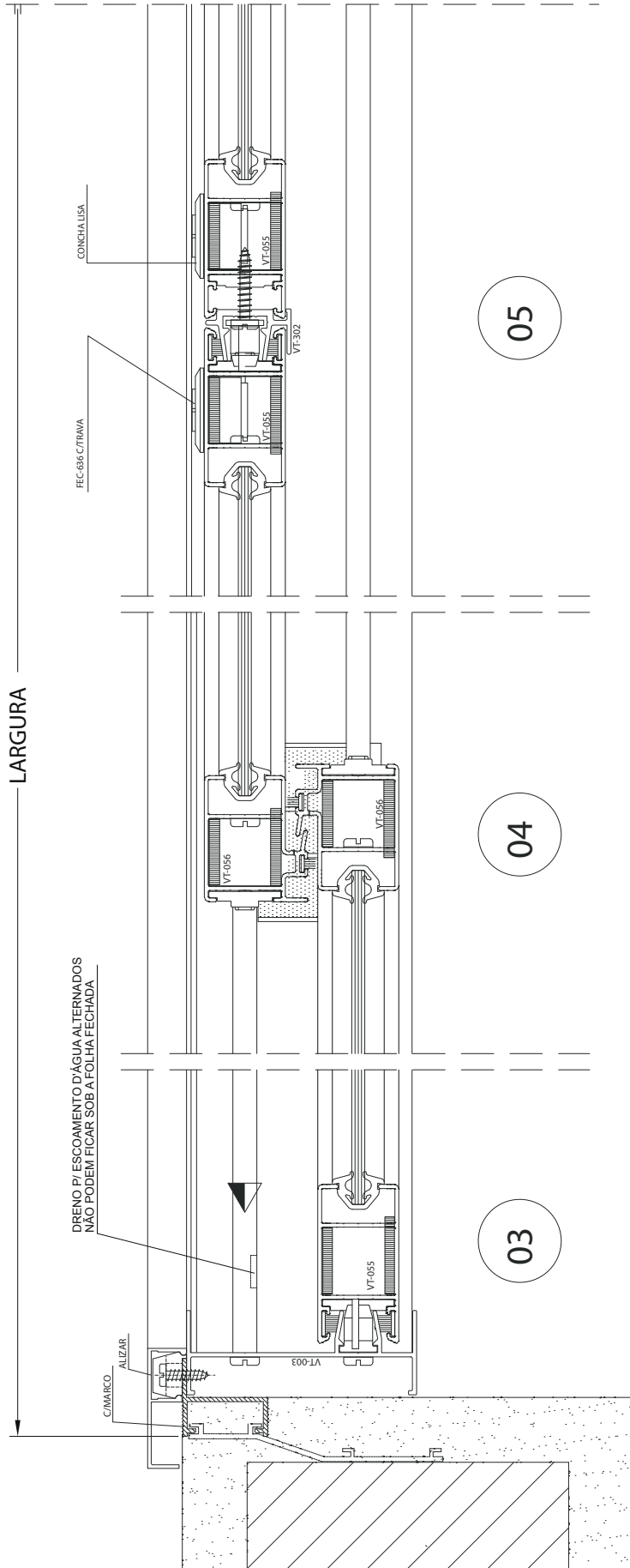

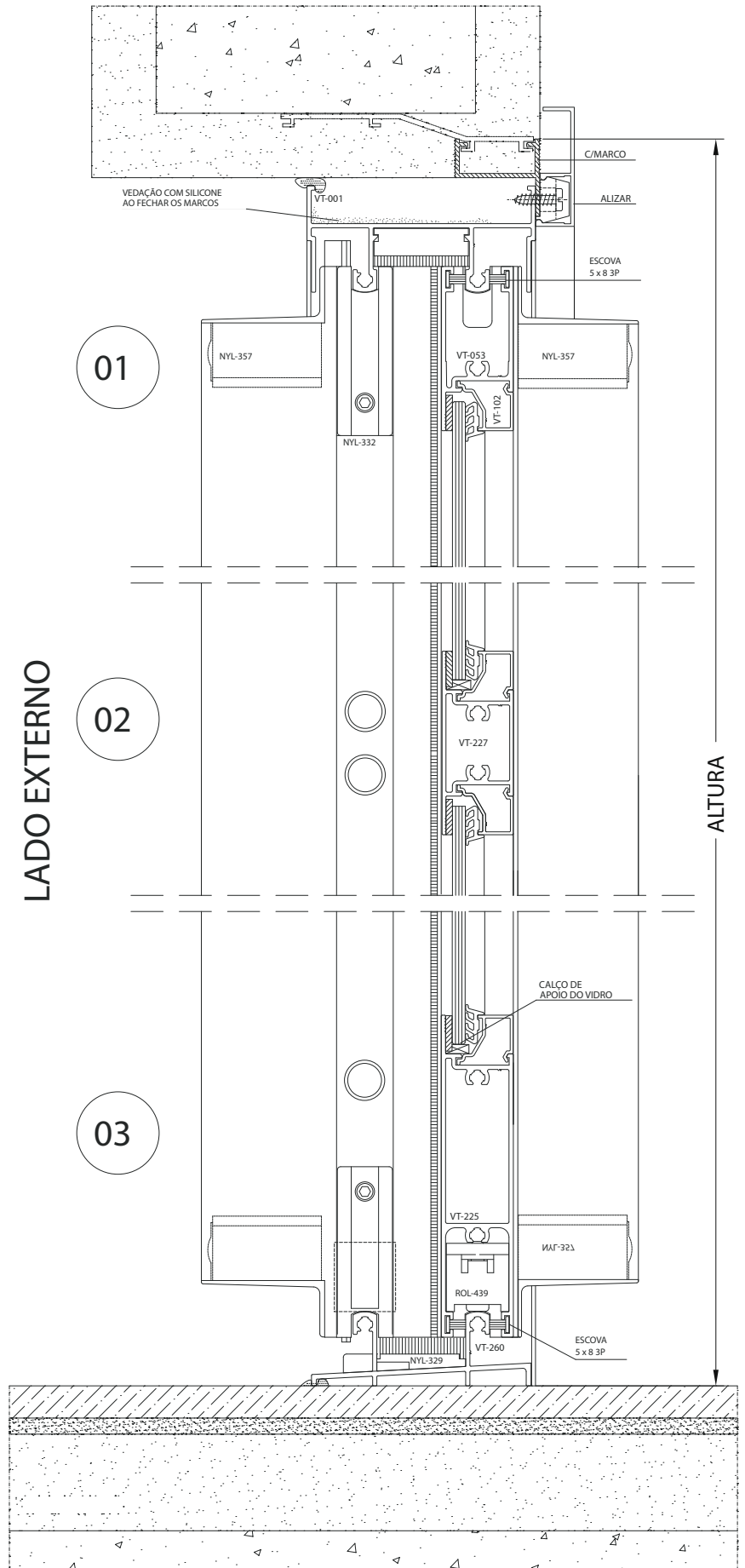
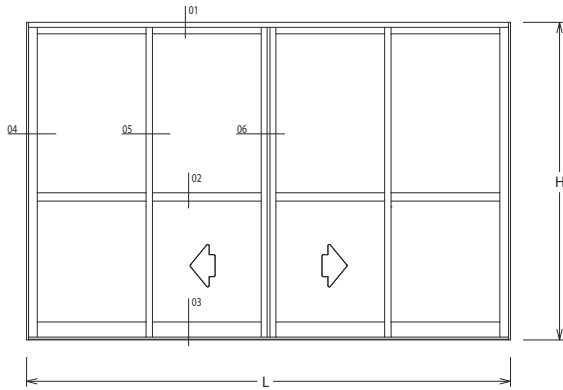

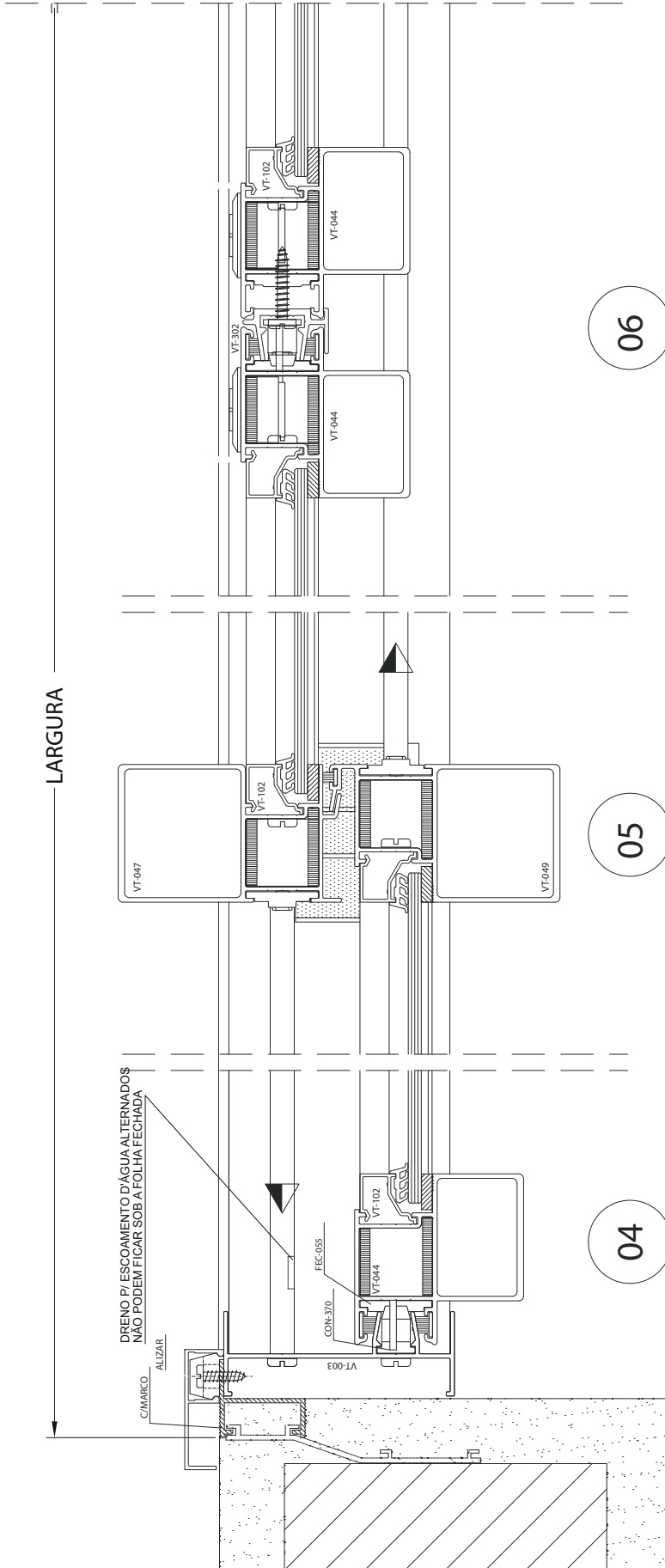

LADO EXTERNO

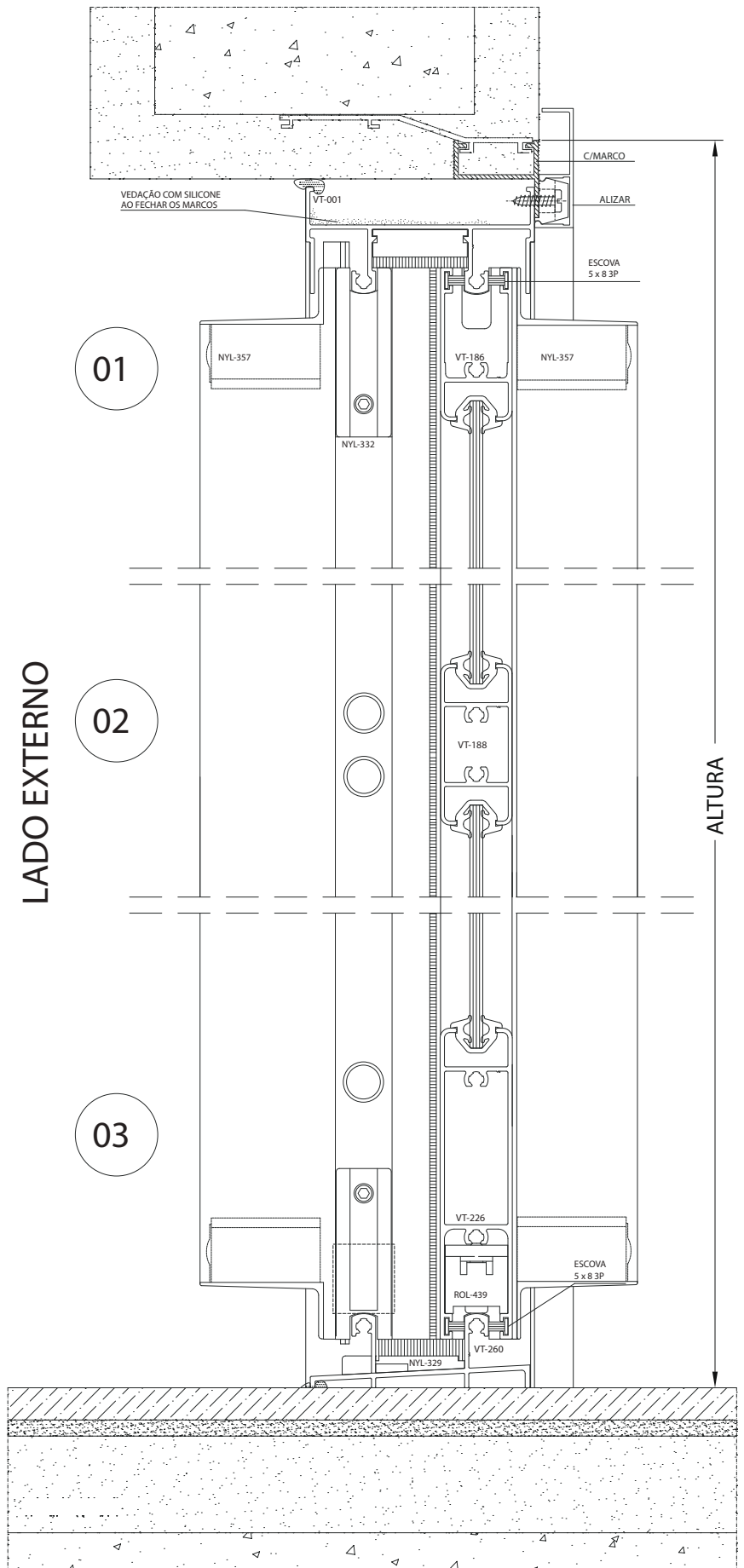
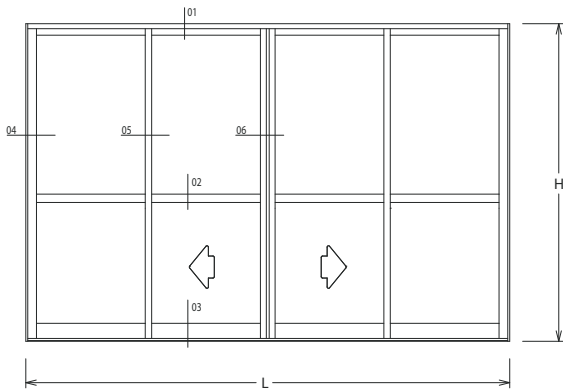

LADO EXTERNO

ALTURA

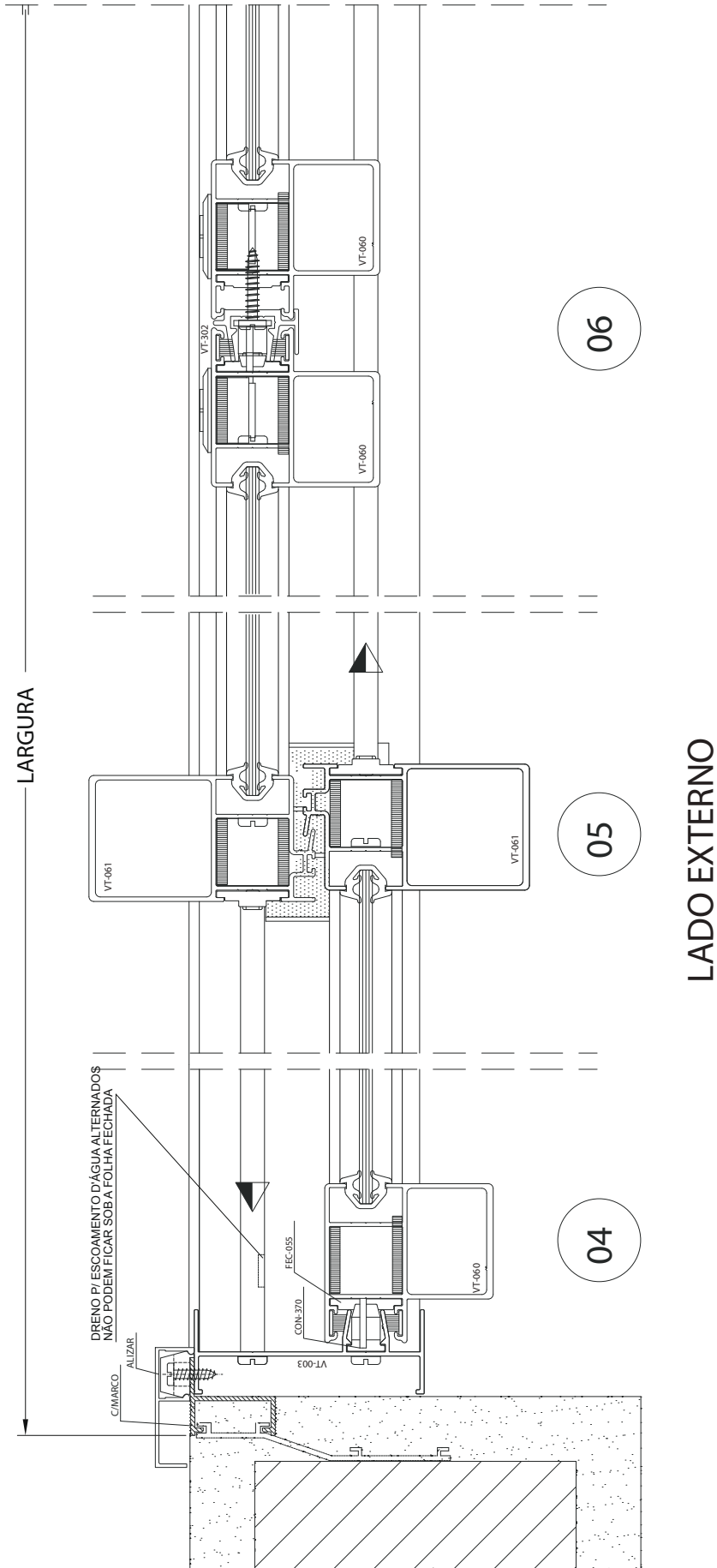

Esquadrias Convencionais

EcoLine 2.5[®]

catálogo de perfis

VENDAS:

perfilcm@perfilcm.com.br

DEPTO. OBRAS:

vendas.obras@perfilcm.com.br

(27) 2104-5900

www.perfilcm.com.br

Responsabilidade Social e Cidadania:



Associado à:



PERFIL
O ALUMÍNIO DO BRASIL

www.perfilcm.com.br